

Spare parts list

(1.517-107.0) KM 70/20 C mit 2.SB

Table of contents

Order instructions	2
KM 70/20 C mit 2.SB (1.517-107.0)	6
47 Spare parts list KM 70/20 C 2SB (5.972-393.0)	7
10 Individual parts	8
20 Side broom	10
21 Side broom right	11
22 Side broom left	13
30 Transmission	15
43 Pinion sprag clutch complete rechts (4.040-791.0)	18
40 Add-on kit waste gripper	19
50 Shearing shackle	21

KM 70/20 C mit 2.SB (1.517-107.0)

POS	Article no.	Description	Quantity	Unit
47	5.972-393.0	Spare parts list KM 70/20 C 2SB	1.000	ST

47 Spare parts list KM 70/20 C 2SB (5.972-393.0)

POS	Description	Quantity	Unit
10	Individual parts	1.000	ST
20	Side broom	1.000	ST
30	Transmission	1.000	ST
40	Add-on kit waste gripper	1.000	ST
50	Shearing shackle	1.000	ST

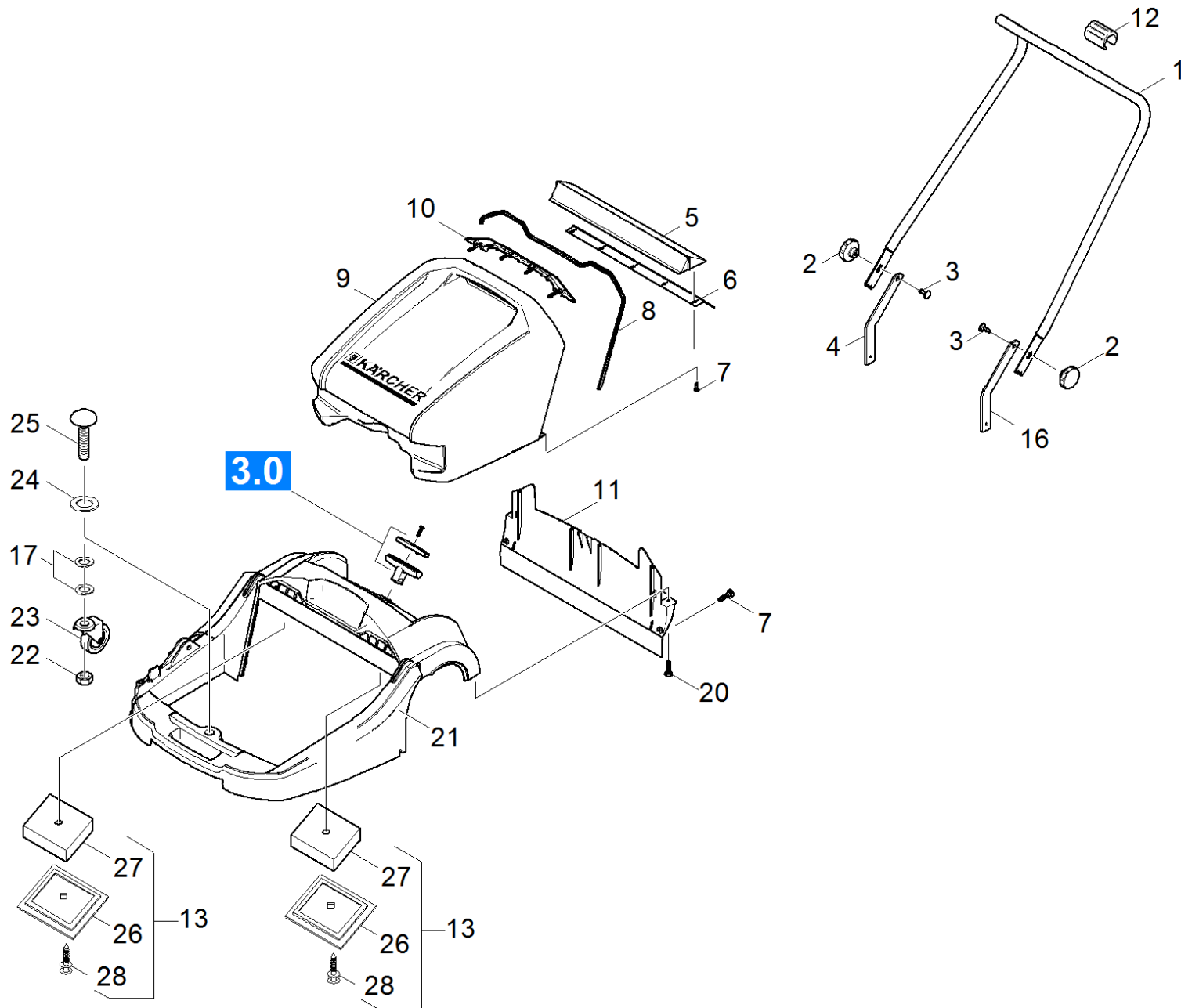

10 Individual parts

POS	Article no.	Description	Quantity	Unit	Remark
1	5.128-775.0	Tube shearing shackle	1.000	ST	
2	6.321-177.0	Turning knob yellow D55mm	2.000	ST	
3	7.303-194.0	Saucer-head screw M8x25-St-A0P DIN 603	2.000	ST	
4	5.058-947.0	Sheet metal component	1.000	ST	
5	6.903-800.0	Holder ground lips sweep tank	1.000	ST	
6	6.903-801.0	Ground lip	1.000	ST	
7	7.303-107.0	Screw 5x16 -10.9-P2R (K-In6Rd)	7.000	ST	
8	6.365-371.0	Profile gasket	1.000	M	
9	4.070-952.0	Sweep tank replacement	1.000	ST	
10	5.064-163.0	Cover	1.000	ST	
11	5.032-641.0	Rear skirting	1.000	ST	
12	6.373-867.0	Clamp	1.000	ST	
13	4.040-772.0	Filter covering cap set	2.000	ST	
15	6.966-043.0	Castor	1.000	ST	
16	5.058-948.0	Sheet metal component	1.000	ST	
17	7.312-005.0	Washer 10-200HV-A3E ISO 7090	2.000	ST	
19	6.385-997.0	Plug	2.000	ST	Version 1
20	7.303-086.0	Screw 5x30 -10.9-R2R (K-In6Rd)	6.000	ST	
21	5.050-251.0	Frame side broom 2	1.000	ST	1.517-103.0
21	5.050-251.0	Frame side broom 2	1.000	ST	1.517-101.0/-121
22	7.311-511.0	Hexagon nut M10-8-A2E ISO 7040	1.000	ST	
23	6.966-053.0	Castor	1.000	ST	1.517-101 ab WK70923, 1.517-103 ab WK27476
24	7.312-262.0	Washer 10 -100HV-A3E ISO 7094	1.000	ST	
25	7.303-222.0	Saucer-head screw M10x80 -St-A0P DIN 60	1.000	ST	
26	5.033-440.0	Covering cap filter	1.000	ST	
27	5.731-642.0	Filter cartridge	1.000	ST	
28	6.385-997.0	Plug	1.000	ST	Version 2

20 Side broom

POS	Description	Quantity	Unit
21	Side broom right	1.000	ST
22	Side broom left	1.000	ST

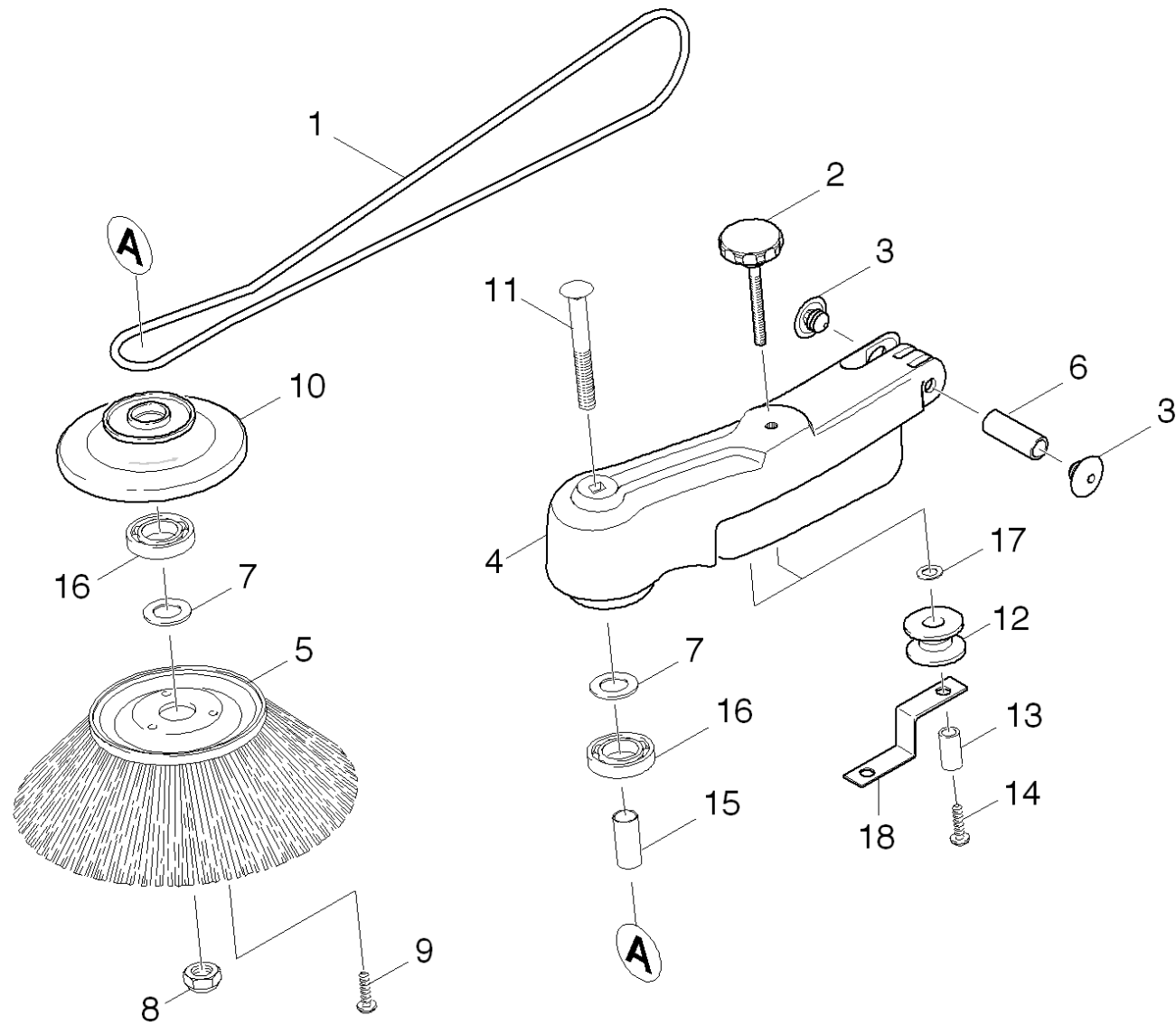

21 Side broom right

POS	Article no.	Description	Quantity	Unit
1	6.348-483.0	Round belt	1.000	ST
2	6.321-176.0	Turning knob yellow D55mm	1.000	ST
3	6.385-935.0	Plug	2.000	ST
4	5.032-638.0	Arm side broom	1.000	ST
5	6.966-005.0	Side broom	1.000	ST
6	5.116-119.0	Sleeve	1.000	ST
7	7.312-153.0	Washer 10 -160HV-A3E EN28738	2.000	ST
8	7.311-511.0	Hexagon nut M10-8-A2E ISO 7040	1.000	ST
9	7.303-112.0	Screw 6x20 -10.9-R2R (In6Rd)	3.000	ST
10	6.966-002.0	Flange	1.000	ST
11	7.303-208.0	Saucer-head screw M10x130-St-A0P DIN 60	1.000	ST
12	6.997-422.0	Deflection pulley	2.000	ST
13	6.966-009.0	Tube 10x1,5x16	2.000	ST
14	7.303-114.0	Screw 6 x 35-ST-10.9-R2R (IN6RD)	2.000	ST
15	6.966-020.0	Spacer sleeve 12x0,8x31	1.000	ST
16	7.401-008.0	Ball bearing 6001-2RS-EDELSTAHL DIN 625	2.000	ST
17	7.312-276.0	Washer 6 -200HV-A2E ISO7093-1	2.000	ST
18	5.061-356.0	Sheet metal component belt side broom	1.000	ST

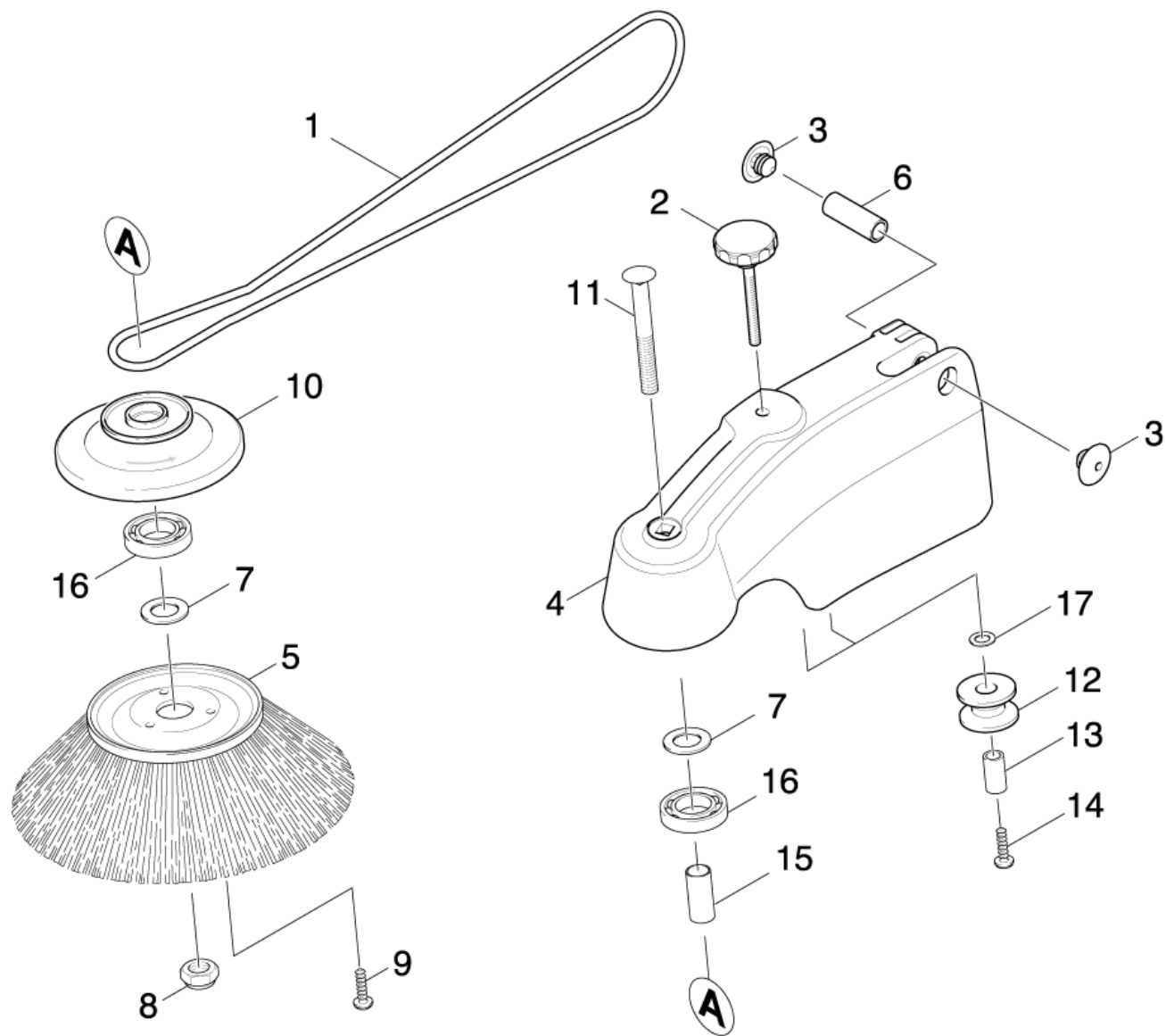

22 Side broom left

POS	Article no.	Description	Quantity	Unit
1	6.348-483.0	Round belt	1.000	ST
2	6.321-176.0	Turning knob yellow D55mm	1.000	ST
3	6.385-935.0	Plug	2.000	ST
4	5.032-671.0	Arm side broom left	1.000	ST
5	6.966-005.0	Side broom	1.000	ST
6	5.116-119.0	Sleeve	1.000	ST
7	7.312-153.0	Washer 10 -160HV-A3E EN28738	2.000	ST
8	7.311-511.0	Hexagon nut M10-8-A2E ISO 7040	1.000	ST
9	7.303-112.0	Screw 6x20 -10.9-R2R (In6Rd)	3.000	ST
10	6.966-002.0	Flange	1.000	ST
11	7.303-208.0	Saucer-head screw M10x130-St-A0P DIN 60	1.000	ST
12	6.997-422.0	Deflection pulley	2.000	ST
13	6.966-009.0	Tube 10x1,5x16	2.000	ST
14	7.303-114.0	Screw 6 x 35-ST-10.9-R2R (IN6RD)	2.000	ST
15	6.966-020.0	Spacer sleeve 12x0,8x31	1.000	ST
16	7.401-008.0	Ball bearing 6001-2RS-EDELSTAHL DIN 625	2.000	ST
17	7.312-276.0	Washer 6 -200HV-A2E ISO7093-1	2.000	ST

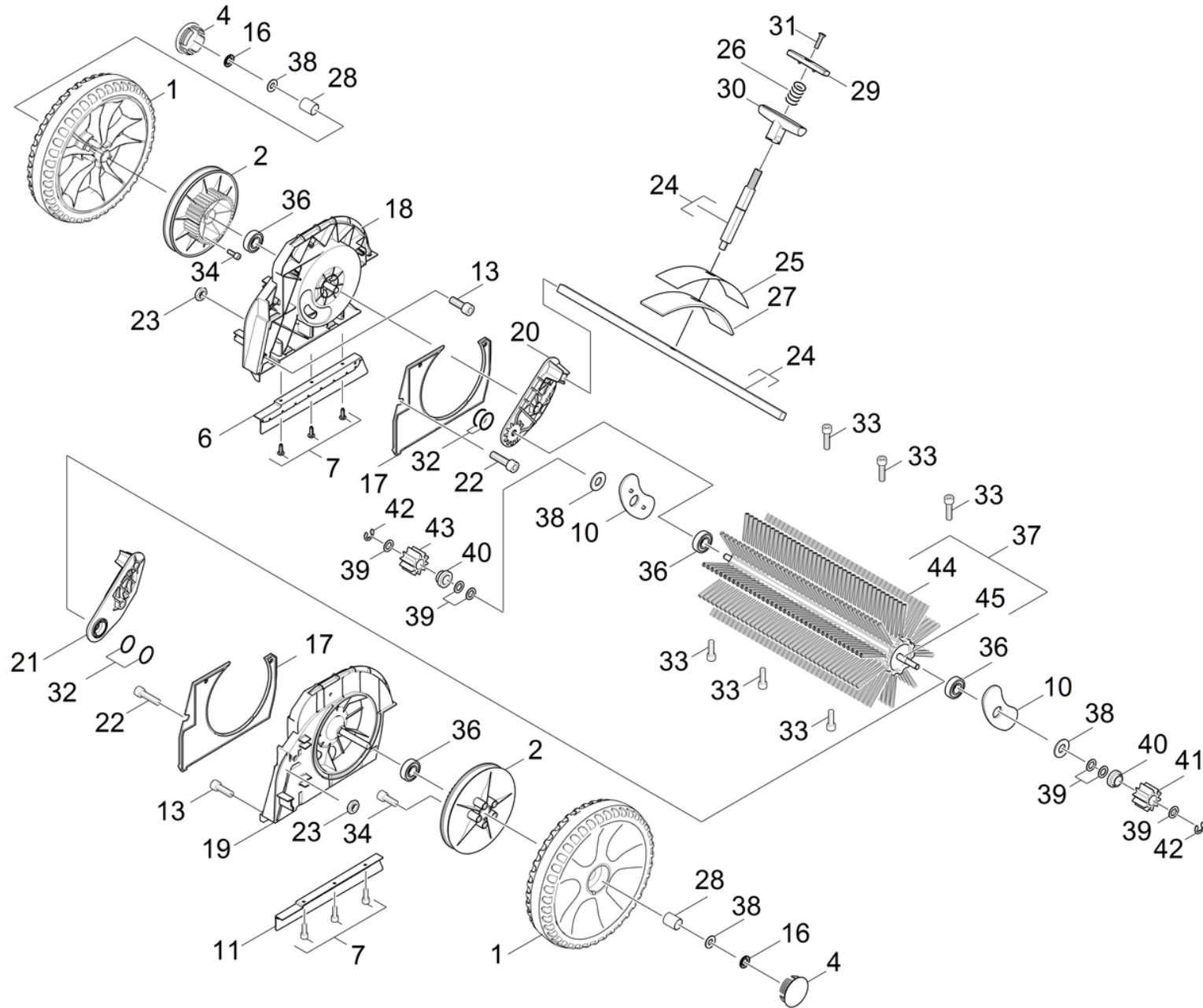

30 Transmission

POS	Article no.	Description	Quantity	Unit	Remark	Foot note text
1	4.515-348.0	Wheel complete	2.000	ST		
2	5.625-451.0	Belt pulley	2.000	ST		
4	5.392-895.0	Wheel cap basalt grey RAL 7012	2.000	ST		BLACK
6	5.394-471.0	Skirting right	1.000	ST		
7	7.303-107.0	Screw 5x16 -10.9-P2R (K-In6Rd)	6.000	ST		
10	6.365-360.0	Gasket disc	2.000	ST		
11	5.394-472.0	Skirting left	1.000	ST		
13	7.303-113.0	Screw 6x25 -10.9-R2R (In6Rd)	2.000	ST		
16	6.343-180.0	Quick-fastener	2.000	ST		
17	5.032-653.0	Covering cap	2.000	ST		
18	5.032-639.0	Axle drum right	1.000	ST		
19	5.032-644.0	Axle drum left	1.000	ST		
20	5.032-640.0	Stub axle right	1.000	ST		
21	5.032-643.0	Stub axle left	1.000	ST		
22	7.306-129.0	Screw M6x40 -8.8-R3R (In6Rd)	2.000	ST		
23	7.311-200.0	Hexagon nut M6 -04-A2E ISO 4035	2.000	ST		
24	4.021-194.0	Angle height adjustment complete	1.000	ST		
25	5.363-630.0	Seal	1.000	ST		
26	5.332-481.0	Helical spring	1.000	ST		
27	5.010-018.0	Plate stainless steel	1.000	ST		
28	6.403-006.0	Plain bearing	2.000	ST		
29	5.326-028.0	Button	1.000	ST		
30	5.321-736.0	Handhold	1.000	ST		
31	7.305-050.0	Countersunk screw M5x20 -A2-70-s (In6Rd)	1.000	ST		
32	6.362-366.0	O-Ring seal 4,0 X 2,0	4.000	ST		
33	7.303-210.0	Screw 5x30 -10.9-A2R (In6Rd)	6.000	ST		
34	7.303-108.0	Screw 5x20 -10.9-R2R (In6Rd)	10.000	ST		
36	6.401-363.0	Ball bearing	4.000	ST		
37	6.907-206.0	Reversing rolling mill complete	1.000	ST	Version 2	
38	5.115-628.0	Washer	4.000	ST	Version 2	
39	7.343-099.0	Shim ring 12x18x0,5 -St2K50 DIN 988	6.000	ST	Version 2	
40	5.033-585.0	Sleeve	2.000	ST	Version 2	

30 Transmission

POS	Article no.	Description	Quantity	Unit	Remark	Foot note text
41	4.040-790.0	Pinion sprag clutch complete links	1.000	ST	Version 2	
42	7.343-047.0	Lock washer 10-FST-A2E DIN 6799	2.000	ST	Version 2	
43	4.040-791.0	Pinion sprag clutch complete rechts	1.000	ST	Version 2	
44	6.906-041.0	Reversing rolling mill	1.000	ST		
45	5.100-641.0	Shaft	1.000	ST		

43 Pinion sprag clutch complete rechts (4.040-791.0)

POS	Article no.	Description	Quantity	Unit
4	5.033-585.0	Sleeve	1.000	ST

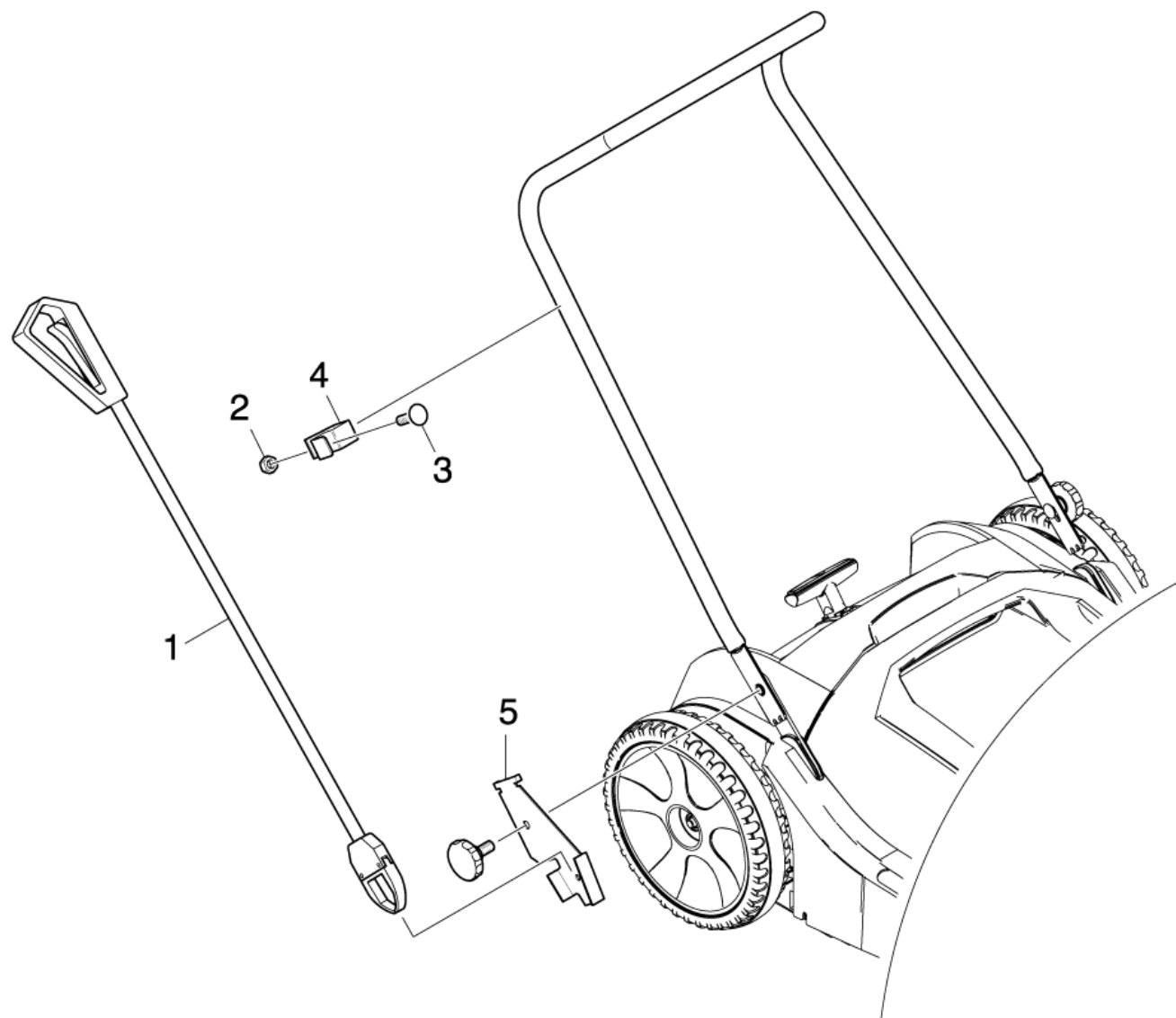

40 Add-on kit waste gripper

POS	Article no.	Description	Quantity	Unit
1	6.369-931.0	Accessories waste gripper Greifboy	1.000	ST
2	7.311-029.0	Hexagon nut M 5-A4-70 ISO 7042	1.000	ST
3	6.303-224.0	Saucer-head screw M5x16-St-A2R DIN 603	1.000	ST
4	5.057-448.0	Sheet metal component waste gripper abov	1.000	ST
5	5.057-447.0	Sheet metal component waste gripper bott	1.000	ST



50 Shearing shackle

POS	Article no.	Description	Quantity	Unit
1	6.373-867.0	Clamp	1.000	ST