

Spare parts list
(5.970-536.0) Spare parts list K 2.26M

Table of contents

Spare parts list K 2.26M (5.970-536.0)	6
10 Housing (0.101-365.0).....	7
20 Pump set (0.107-288.0).....	9
21 Cylinder head (0.107-200.0).....	10
22 Thrust guidance (0.107-172.0).....	12
30 Motor (0.111-307.0).....	14
40 Accessories (0.148-766.0).....	16
41 Hand trigger gun (0.148-367.0).....	17
42 Hand trigger gun (0.110-638.0).....	19
5 Spare part set O-Ring seal 5x (2.880-296.0).....	21
43 Hand trigger gun (0.113-277.0).....	22
4 Spare part set O-Ring seal 5x (2.880-296.0).....	24
44 Hand trigger gun (0.116-630.0).....	25
45 Jet pipe (0.148-768.0).....	27
46 Surface cleaner (0.148-964.0).....	29

Spare parts list K 2.26M (5.970-536.0)

Pos	Name	Qty.	Unit	from ser.nr.	up to ser.nr.
10	Housing	1.000	ST	0000000000	0000000000
20	Pump set	1.000	ST	0000000000	0000000000
30	Motor	1.000	ST	0000000000	0000000000
40	Accessories	1.000	ST	0000000000	0000000000

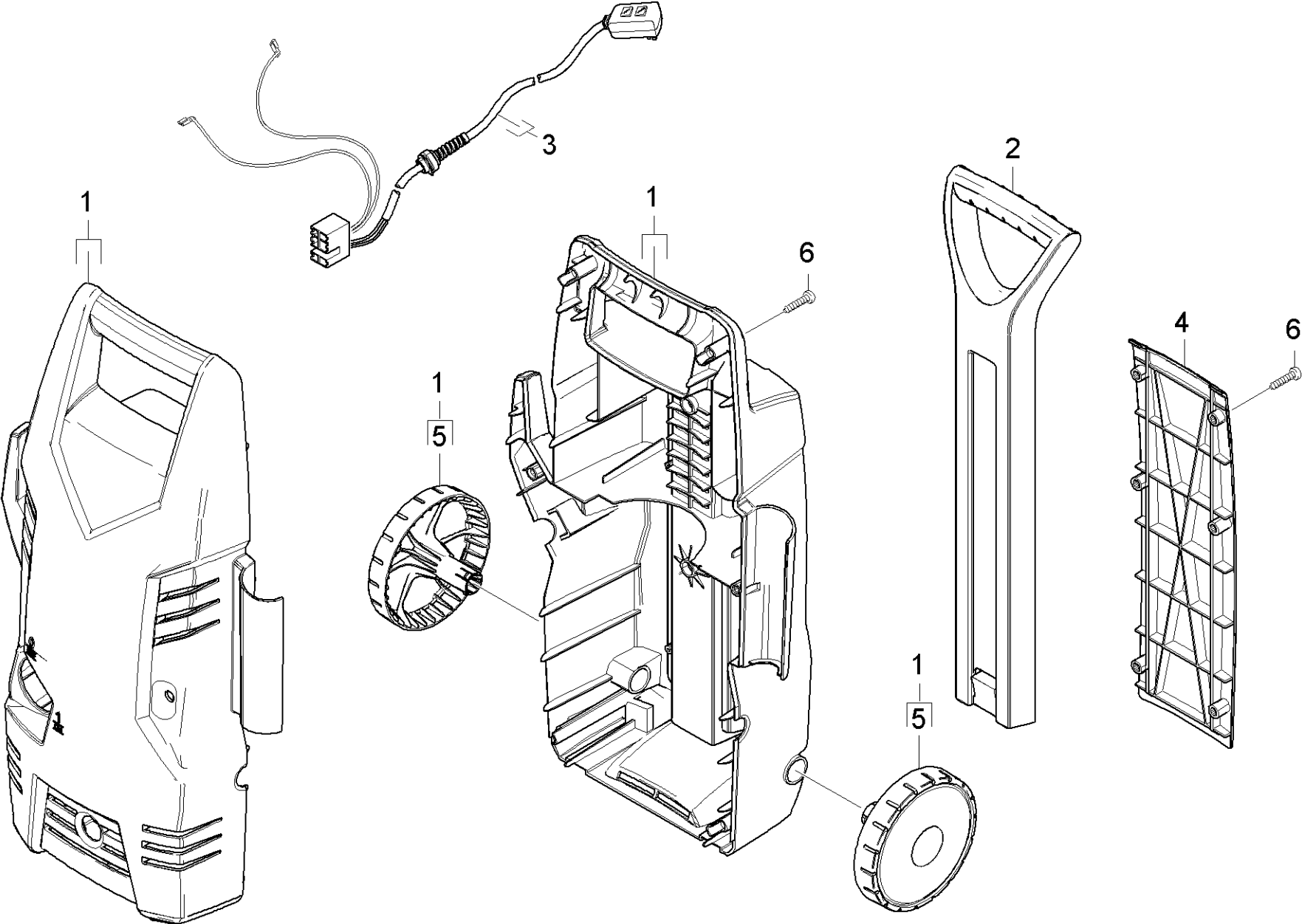

10 Housing (0.101-365.0)

Pos	Material #	Name	Qty.	Unit	from ser.nr.	up to ser.nr.	Footnote text
1	9.755-043.0	Housing pair with wheels	1.000	ST	0000000000	0000000000	
2	9.760-260.0	K2.26M handle	1.000	ST	0000000000	0000000000	
3	9.755-187.0	Cable complete replacement *MX	1.000	ST			
Position text: 1.601-607.0							
3	9.755-185.0	Cable complete replacement	1.000	ST	0000000000	0000000000	
Position text: 1.601-602.0 /-608.0 /-609.0							
3	9.755-185.0	Cable complete replacement	1.000	ST			
Position text: 1.601-601.0 /-604.0							
4	9.760-255.0	Cover for handle K2.26M	1.000	ST	0000000000	0000000000	
5	9.750-408.0	Wheel set replacement Winner 150	1.000	ST	0000000000	0000000000	SET OF 2 PIECES
6	9.086-173.0	Screw Hi-Lo d.4x22 Torx-d.7,5	12.000	ST	0000000000	0000000000	

20 Pump set (0.107-288.0)

Pos	Name	Qty.	Unit	from ser.nr.	up to ser.nr.
21	Cylinder head	1.000	ST	0000000000	0000000000
22	Thrust guidance	1.000	ST	0000000000	0000000000

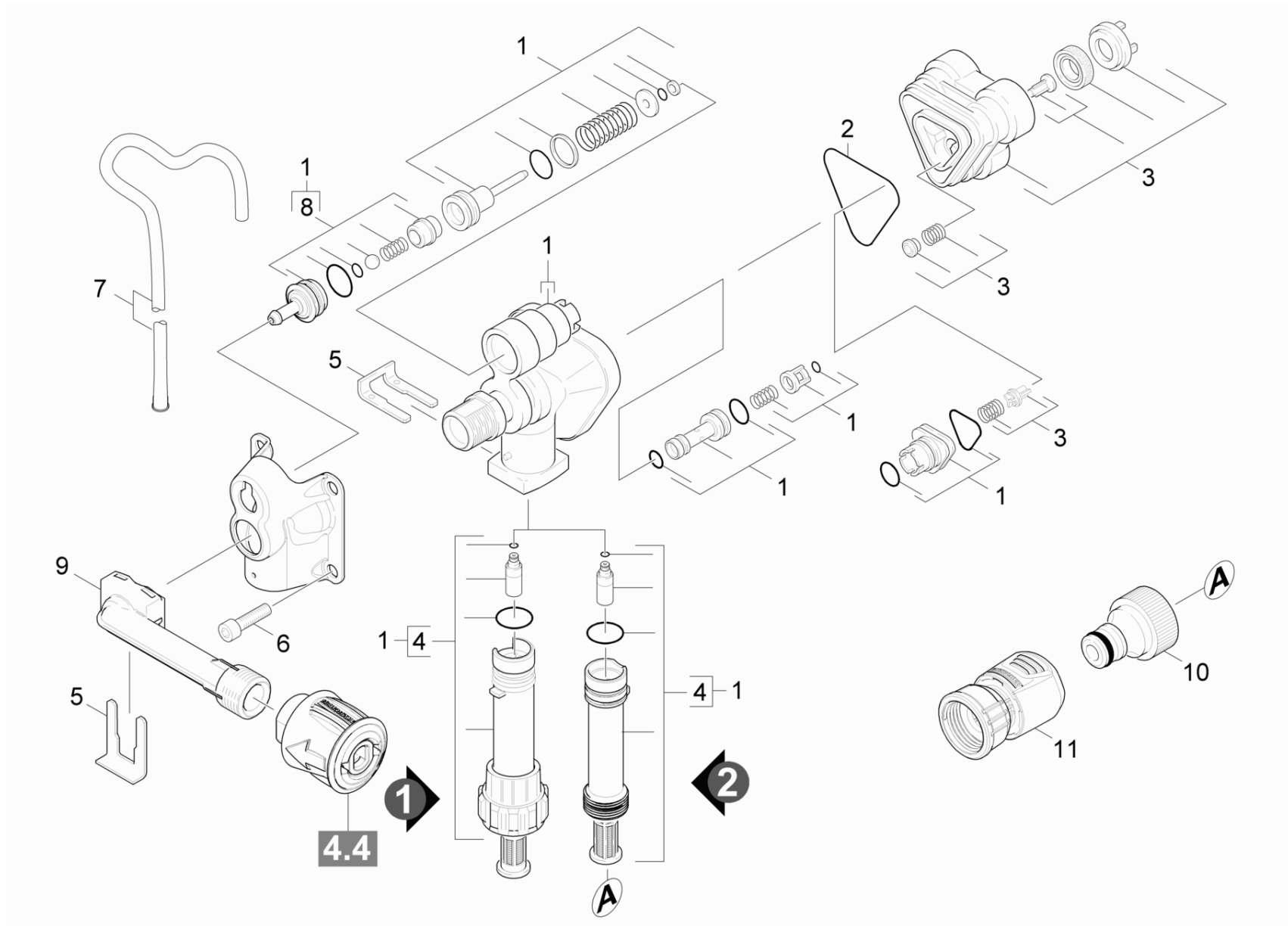

21 Cylinder head (0.107-200.0)

ET/VT (spare/wear parts)	Pos	Material #	Name	Qty.	Unit	from ser.nr.	up to ser.nr.	Footnote text
X	1	9.755-010.0	Housing complete replacement K 2.29	1.000	ST			VERSION 2
Position text: 1.601-601.0 /-604.0 /-607.0 /-608.0 /-609.0								
X	1	9.755-040.0	Housing complete replacement K 2.26 *	1.000	ST	0000000000	0000000000	VERSION 1
Position text: 1.601-602.0 /-608.0 /-609.0								
X-X	2	9.081-422.0	Form seal	1.000	ST	0000000000	0000000000	
X-X	3	9.755-020.0	H.P. head complete Spare Part	1.000	ST	0000000000	0000000000	
X	4	9.755-041.0	Suction connection replacement +SV	1.000	ST	0000000000	0000000000	VERSION 1
Position text: 1.601-602.0 /-608.0 /-609.0								
	4	9.755-011.0	Suction connection complete replacement	1.000	ST			VERSION 2
Position text: 1.601-601.0 /-604.0 /-607.0 /-608.0 /-609.0								
	5	9.039-148.0	Metal fork	2.000	ST	0000000000	0000000000	
	6	7.306-151.0	Cylinder head screw M8x65 -8.8-A2E ISO4	4.000	ST	0000000000	0000000000	
	7	9.011-911.0	Filter cleaning agents W107/207	1.000	ST	0000000000	0000000000	
	8	9.755-183.0	Nipple chemistry spare part - straight	1.000	ST	0000000000	0000000000	
X-X	9	9.036-703.0	Connection delivery side	1.000	ST	0000000000	0000000000	
X-X	10	6.465-031.0	Connection 3/4	1.000	ST			
X	11	4.645-365.0	Coupler with label complete	1.000	ST			

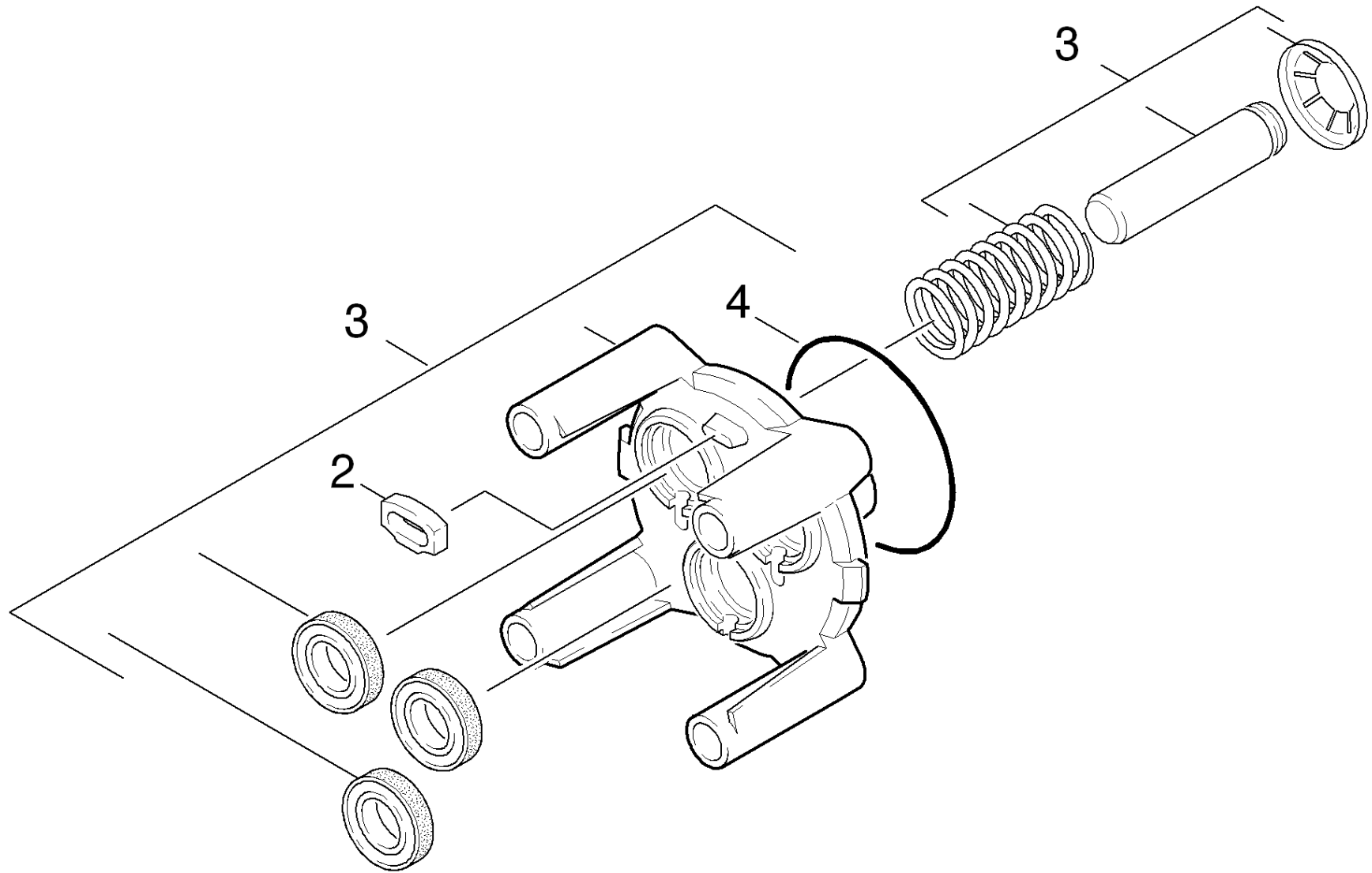

22 Thrust guidance (0.107-172.0)

Pos	Material #	Name	Qty.	Unit	from ser.nr.	up to ser.nr.
2	9.048-071.0	Spacer - Seal	1.000	ST	0000000000	0000000000
3	9.755-018.0	Piston guidance complete replacement	1.000	ST	0000000000	0000000000
4	6.363-339.0	O-Ring seal 60x2,5 -NBR 80	1.000	ST	0000000000	0000000000

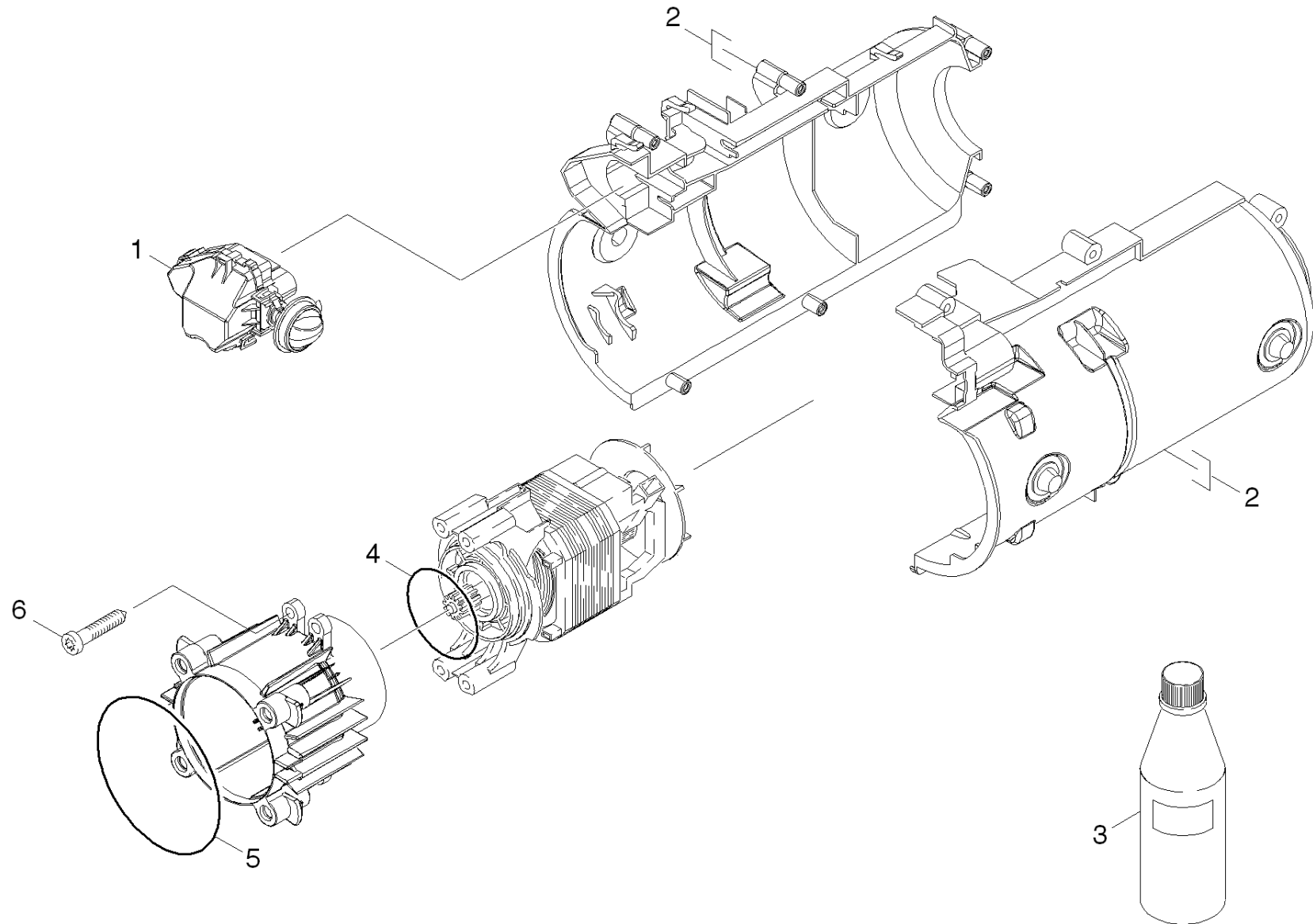

30 Motor (0.111-307.0)

Pos	Material #	Name	Qty.	Unit	from ser.nr.	up to ser.nr.
1	9.755-342.0	Electric box complete replacement K 2.26	1.000	ST	0000000000	0000000000
Position text: 1.601-601.0 /-602.0 /-604.0 /-608.0/-609.0						
1	9.755-347.0	Electric box complete replacement K2.21	1.000	ST		
Position text: 1.601-607.0						
2	9.755-030.0	Housing motor replacement V0 (CEN)	1.000	ST	0000000000	0000000000
3	6.288-112.0	Engine oil 1L	1.000	ST	0000000000	0000000000
4	6.363-340.0	O-Ring 50 x 2,2 NBR 80	1.000	ST	0000000000	0000000000
5	6.363-339.0	O-Ring seal 60x2,5 -NBR 80	1.000	ST	0000000000	0000000000
6	6.303-260.0	Screw 5x26,4	4.000	ST	0000000000	0000000000

40 Accessories (0.148-766.0)

Pos	Name	Qty.	Unit	from ser.nr.	up to ser.nr.	var. information
41	Hand trigger gun	1.000	ST	0000000000	0000000000	VERSION 1
42	Hand trigger gun	1.000	ST			VERSION 2
43	Hand trigger gun	1.000	ST			VERSION 3
44	Hand trigger gun	1.000	ST			VERSION 4
45	Jet pipe	1.000	ST	0000000000	0000000000	
46	Surface cleaner	1.000	ST	0000000000	0000000000	

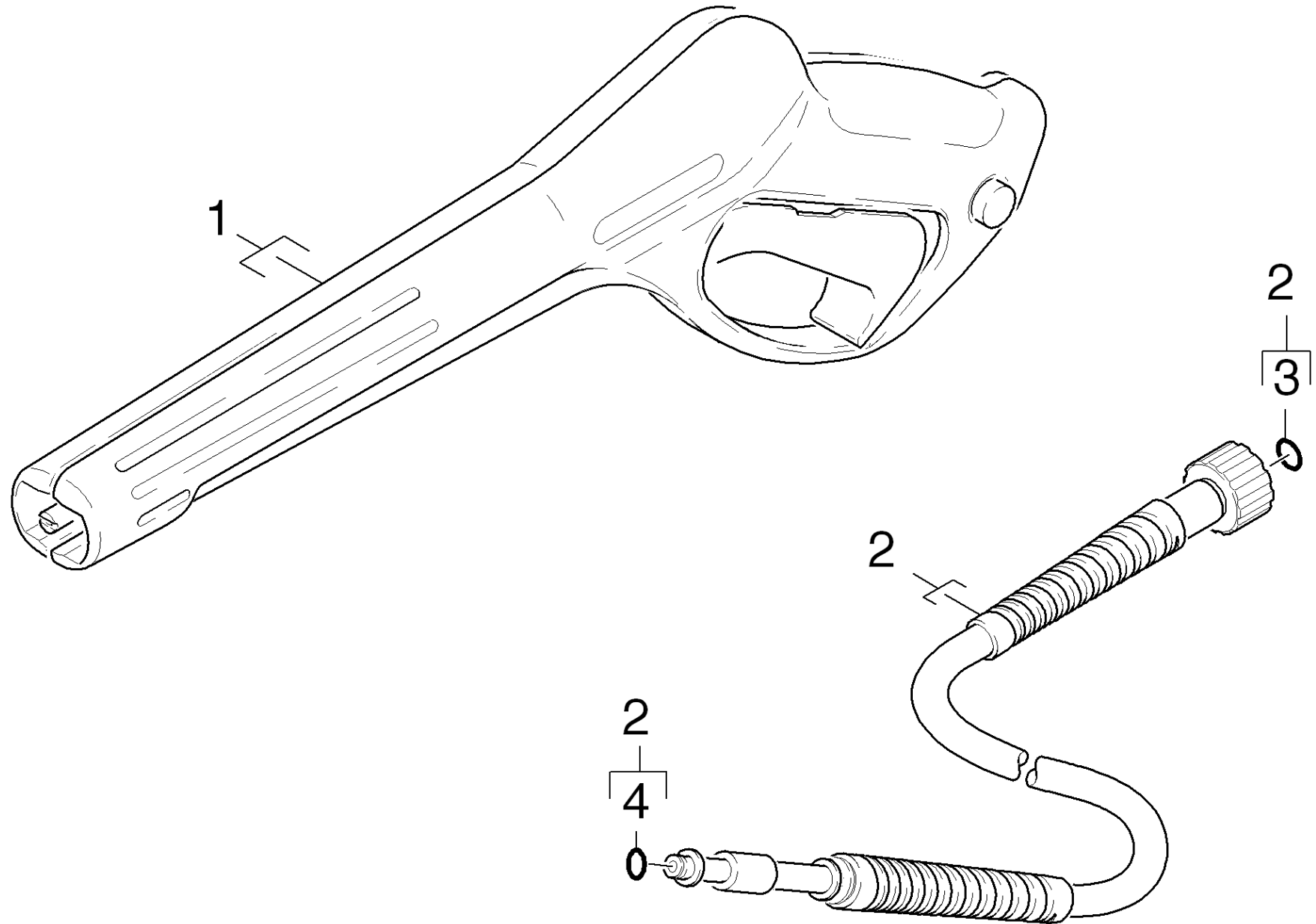

41 Hand trigger gun (0.148-367.0)

ET/VT (spare/wear parts)	Pos	Material #	Name	Qty.	Unit	from ser.nr.	up to ser.nr.
	1	4.775-331.0	Pistol replacement 97K	1.000	ST	0000000000	0000000000
	2	6.391-571.0	High pressure hose 6/11MPA, neutr.,40G,M	1.000	ST	0000000000	0000000000
X-X	3	2.880-154.0	O-Ring kit	1.000	ST	0000000000	0000000000
X	4	6.362-498.0	O-Ring seal 6,75x1,78 NBR 70	1.000	ST	0000000000	0000000000

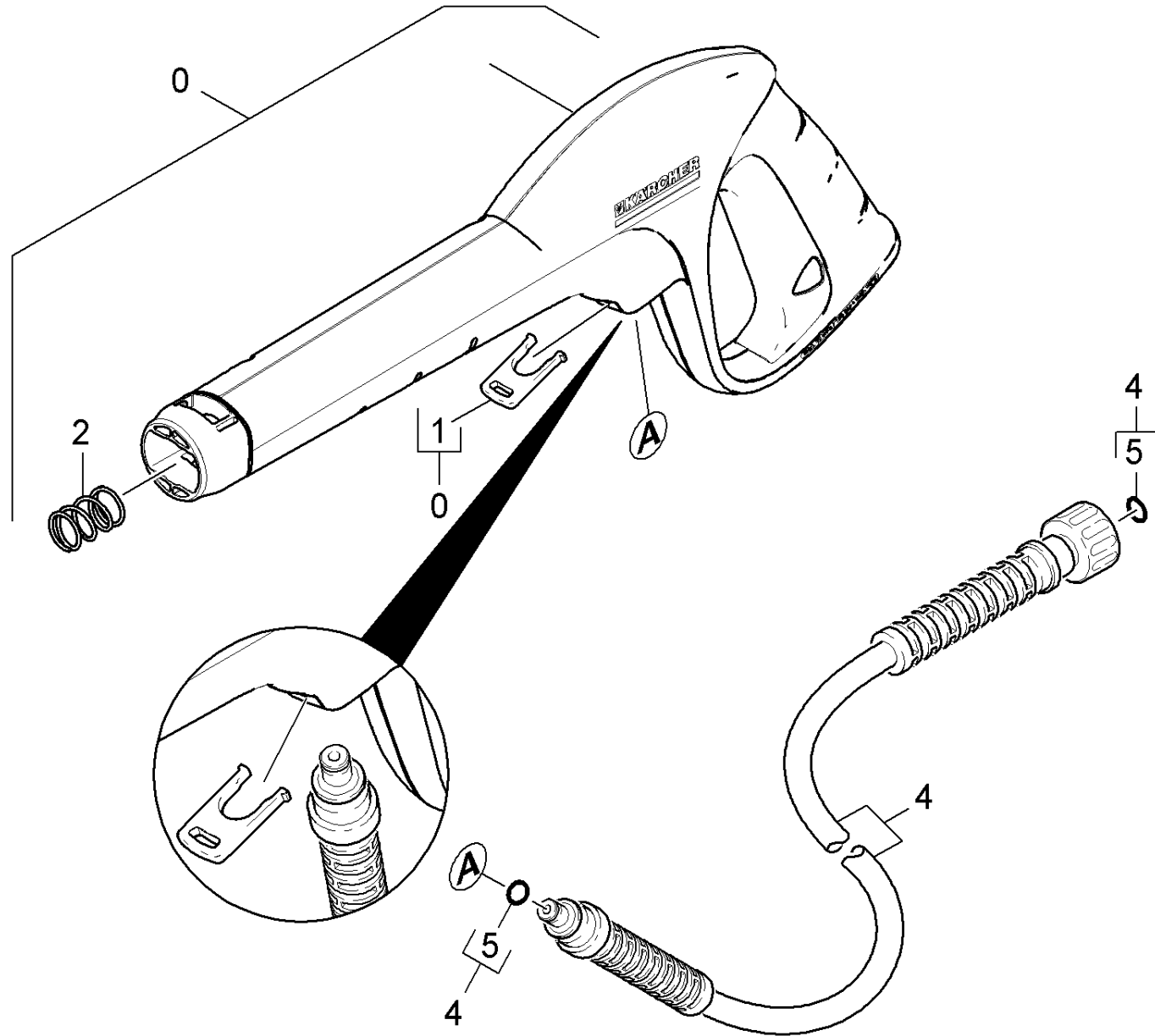

42 Hand trigger gun (0.110-638.0)

ET/VT (spare/wear parts)	Pos	Material #	Name	Qty.	Unit	var. information
X-X	0	2.641-959.0	Pistol good packaged replacement 16MPa/6	1.000	ST	
Position text: 1.601-601.0 /-602.0 /-607.0 /-608.0 /-609.0						
X	1	5.037-185.0	Clamp	1.000	ST	
	2	5.332-464.0	Pressure spring	1.000	ST	
X	4	6.391-788.0	High pressure hose 14/9 40° C	1.000	ST	(9m)
Position text: 1.601-609.0						
X-X	4	6.390-871.0	High pressure hose 6/11MPa	1.000	ST	(6m)
Position text: 1.601-601.0 /-602.0 /-607.0 /-608.0						
X-X	5	2.880-296.0	Spare part set O-Ring seal 5x	1.000	ST	
X	6	6.362-498.0	O-Ring seal 6,75x1,78 NBR 70	1.000	ST	

5 Spare part set O-Ring seal 5x (2.880-296.0)

Pos	Material #	Name	Qty.	Unit	from ser.nr.	up to ser.nr.
10	6.362-957.0	O-Ring seal 10,0 X 2,0-EPDM 85-90	5.000	ST	0000000000	0000000000

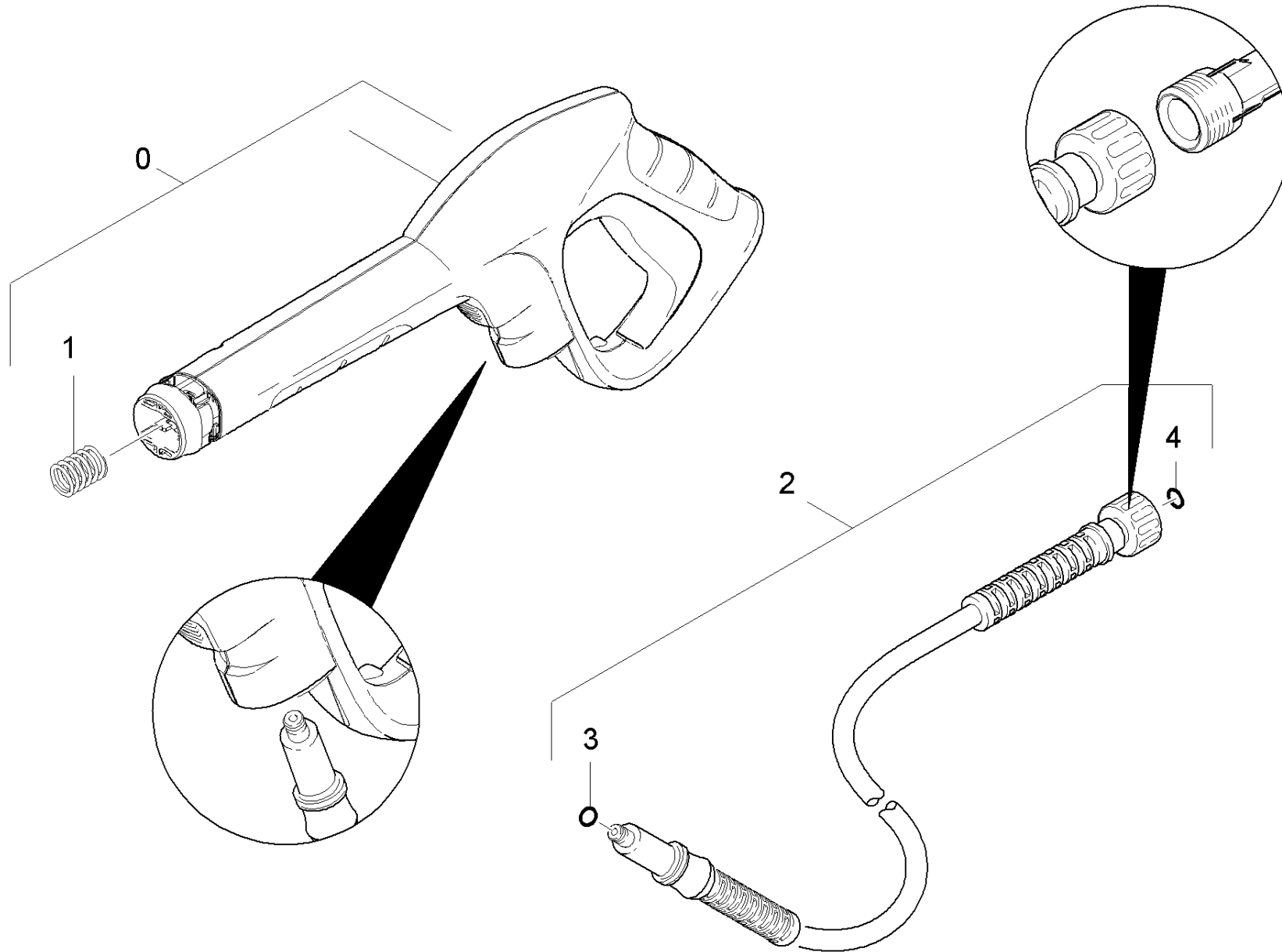

43 Hand trigger gun (0.113-277.0)

ET/VT (spare/wear parts)	Pos	Material #	Name	Qty.	Unit
X-X	0	2.642-172.0	Pistol best 2K verpackt	1.000	ST
Position text: 1.601-601.0 /-608.0 /-609.0					
	1	5.332-464.0	Pressure spring	1.000	ST
X	2	6.392-352.0	High pressure hose 11/7,5 40°C	1.000	ST
X-X	3	6.363-410.0	O-Ring seal 5,7x1,78 NBR 90Shore	1.000	ST
X-X	4	2.880-296.0	Spare part set O-Ring seal 5x	1.000	ST

4 Spare part set O-Ring seal 5x (2.880-296.0)

Pos	Material #	Name	Qty.	Unit	from ser.nr.	up to ser.nr.
10	6.362-957.0	O-Ring seal 10,0 X 2,0-EPDM 85-90	5.000	ST	0000000000	0000000000

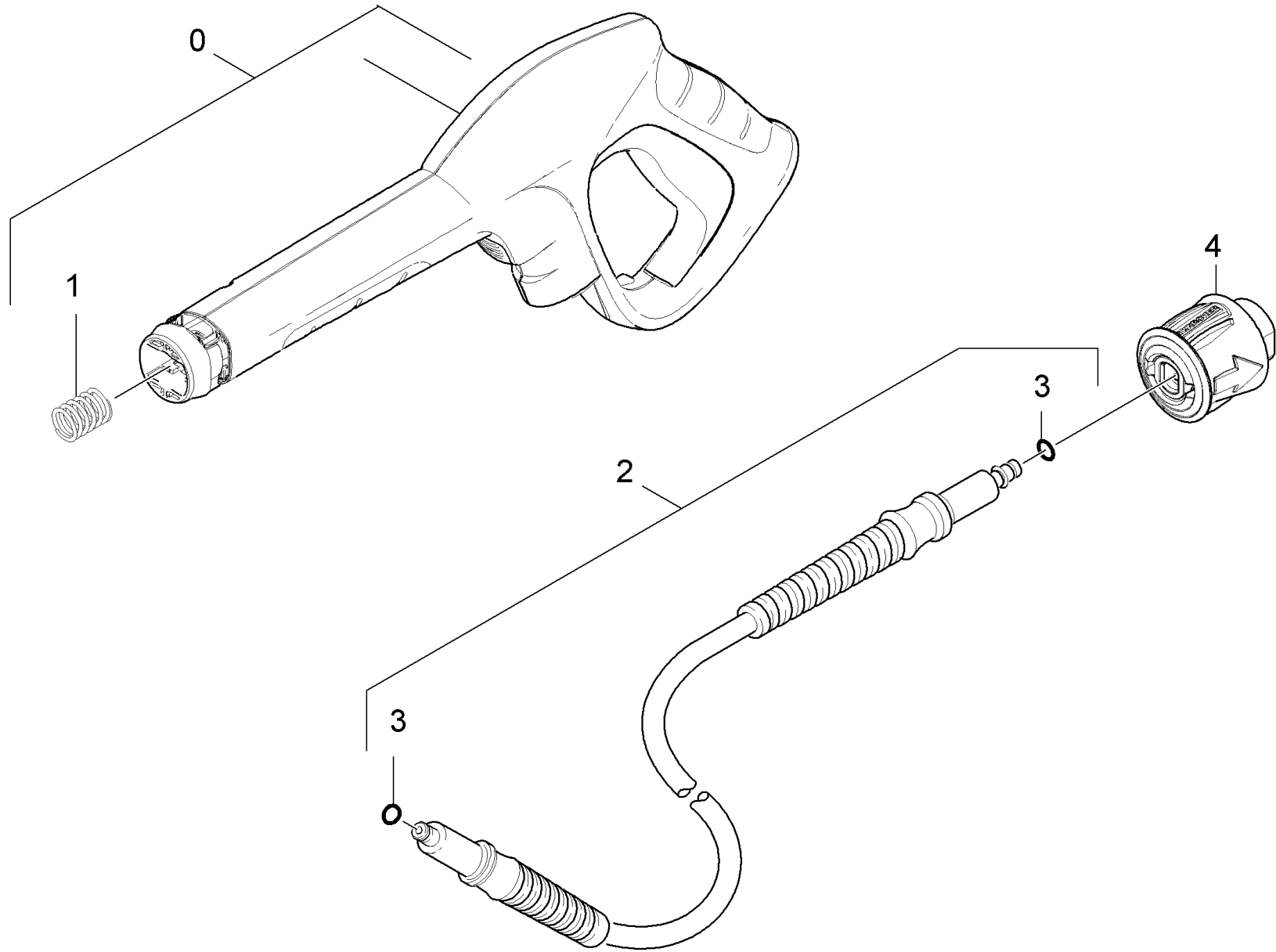

44 Hand trigger gun (0.116-630.0)

ET/VT (spare/wear parts)	Pos	Material #	Name	Qty.	Unit
X-X	0	2.642-172.0	Pistol best 2K verpackt	1.000	ST
	1	5.332-464.0	Pressure spring	1.000	ST
	2	6.392-966.0	High pressure hose 11/10 40°C	1.000	ST
X-X	3	6.363-410.0	O-Ring seal 5,7x1,78 NBR 90Shore	2.000	ST
X	4	4.470-041.0	High pressure quick-fitting pipe union A	1.000	ST

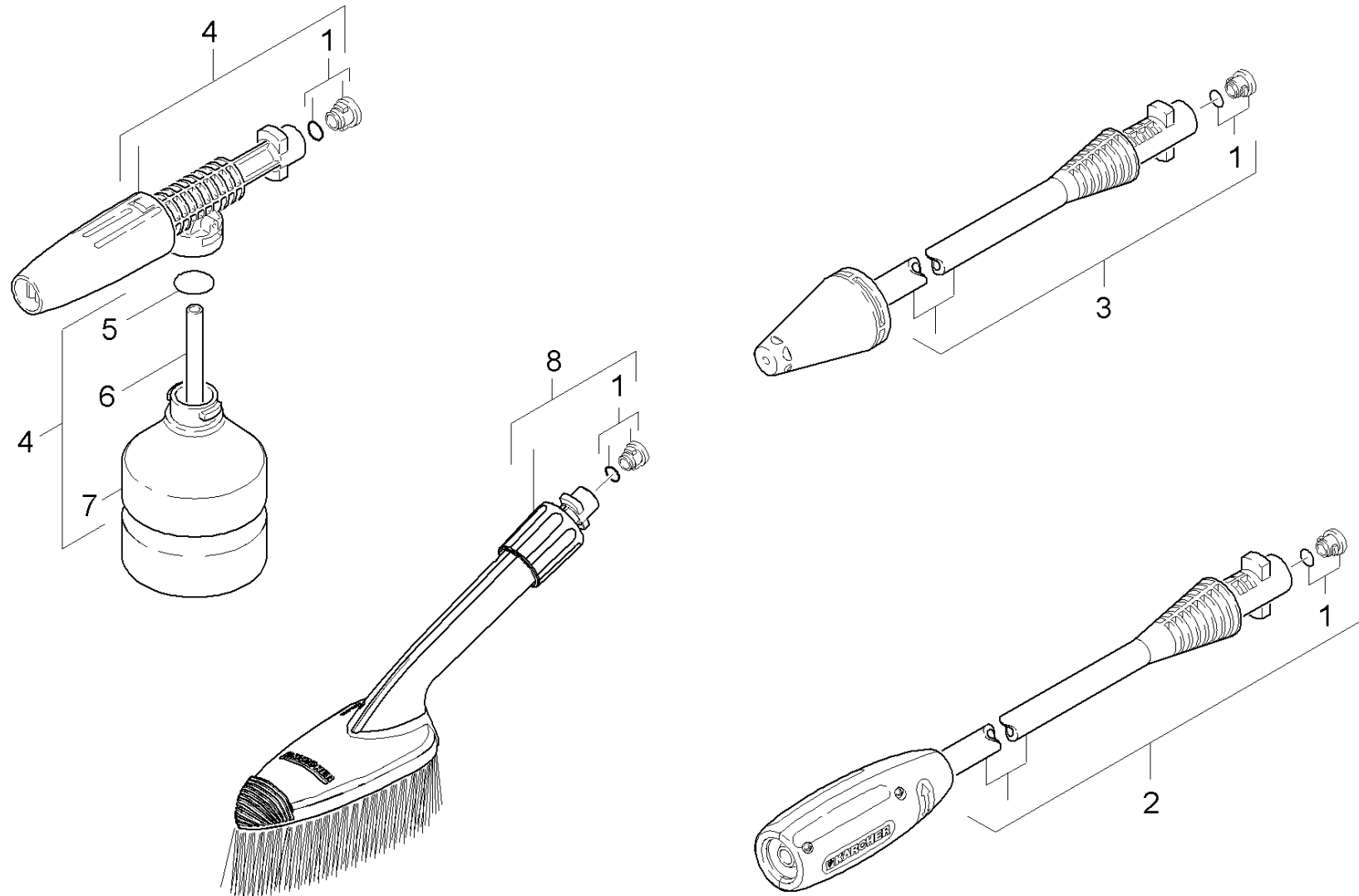

45 Jet pipe (0.148-768.0)

ET/VT (spare/wear parts)	Pos	Material #	Name	Qty.	Unit	from ser.nr.	up to ser.nr.	Footnote text
X-X	1	2.640-729.0	O-Ring seal set	1.000	ST	0000000000	0000000000	
X	2	4.760-601.0	VPS K2 021 K	1.000	ST	0000000000	0000000000	
Position text: 1.601-601.0 /-602.0 /-604.0 /-608.0/-609.0								
X	2	4.760-535.0	VPS K2 025	1.000	ST			
Position text: 1.601-607.0								
X	3	9.750-674.0	Dirt blaster 024 CEN-St (14MPa)	1.000	ST			
Position text: 1.601-602.0								
	3	4.764-243.0	Dirt blaster K2 027 St	1.000	ST			
Position text: 1.601-601.0 /-604.0 /-607.0 /-608.0/-609.0								
X-X	4	2.641-848.0	Foam nozzle packaged 0,3 l	1.000	ST			
Position text: 1.601-608.0 /-609.0								
	5	6.964-008.0	O-Ring seal 21,0 X 3,0	1.000	ST			
	6	6.388-216.0	Hose DN 5	1.000	M			TO ORDER AS CUT GOODS
	7	6.964-007.0	Bottle chemistry	1.000	ST			
X-X	8	2.640-589.0	Brush lengthwise	1.000	ST			
Position text: 1.601-608.0 /-609.0								

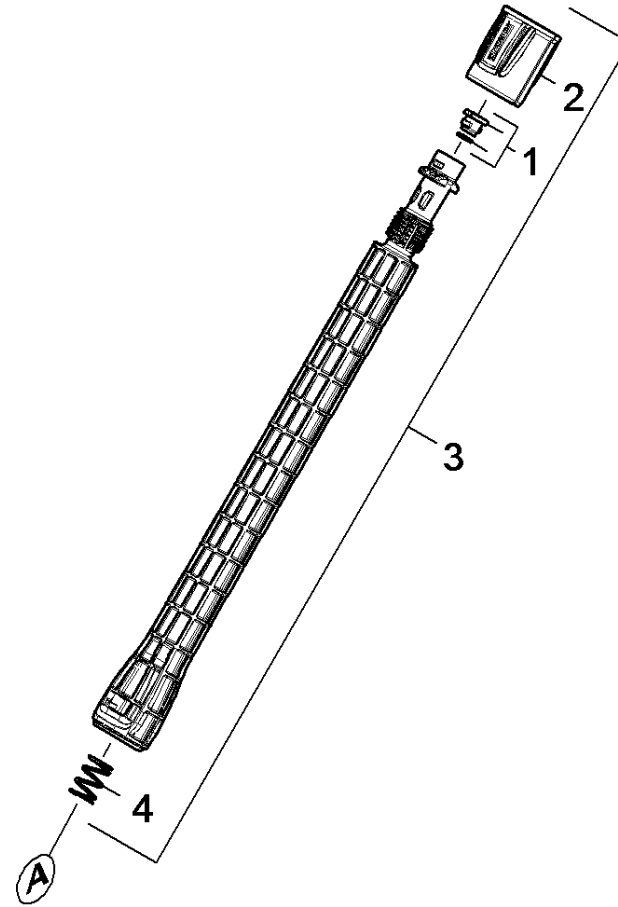
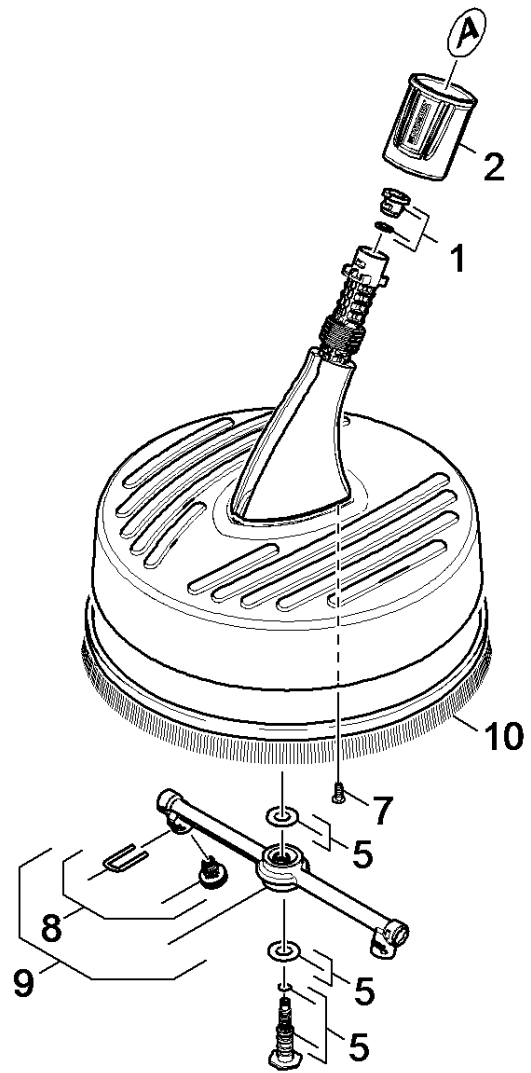

46 Surface cleaner (0.148-964.0)

ET/VT (spare/wear parts)	Pos	Material #	Name	Qty.	Unit	from ser.nr.	up to ser.nr.
X-X	1	2.640-729.0	O-Ring seal set	1.000	ST	0000000000	0000000000
	2	5.310-160.0	Nut Kaercher	2.000	ST	0000000000	0000000000
X-X	3	4.760-262.0	Jet pipe extension 0,4m	1.000	ST		
Position text: 1.601-607.0							
	3	4.760-707.0	Jet pipe 0,4m *KNA	1.000	ST	0000000000	0000000000
Position text: 1.601-608.0 /-609.0							
	4	5.332-464.0	Pressure spring	2.000	ST	0000000000	0000000000
	5	2.883-994.0	Spare part set set of gaskets neutrally	1.000	ST	0000000000	0000000000
	7	7.303-106.0	Screw 4x12 -10.9-R2R (IN6RD)	3.000	ST	0000000000	0000000000
X	8	2.640-727.0	Spare part set nozzles 015	1.000	ST	0000000000	0000000000
	9	2.884-530.0	Spare part set rotor T 50	1.000	ST	0000000000	0000000000
	10	6.369-978.0	Strip brush complete T 50	1.000	ST	0000000000	0000000000