

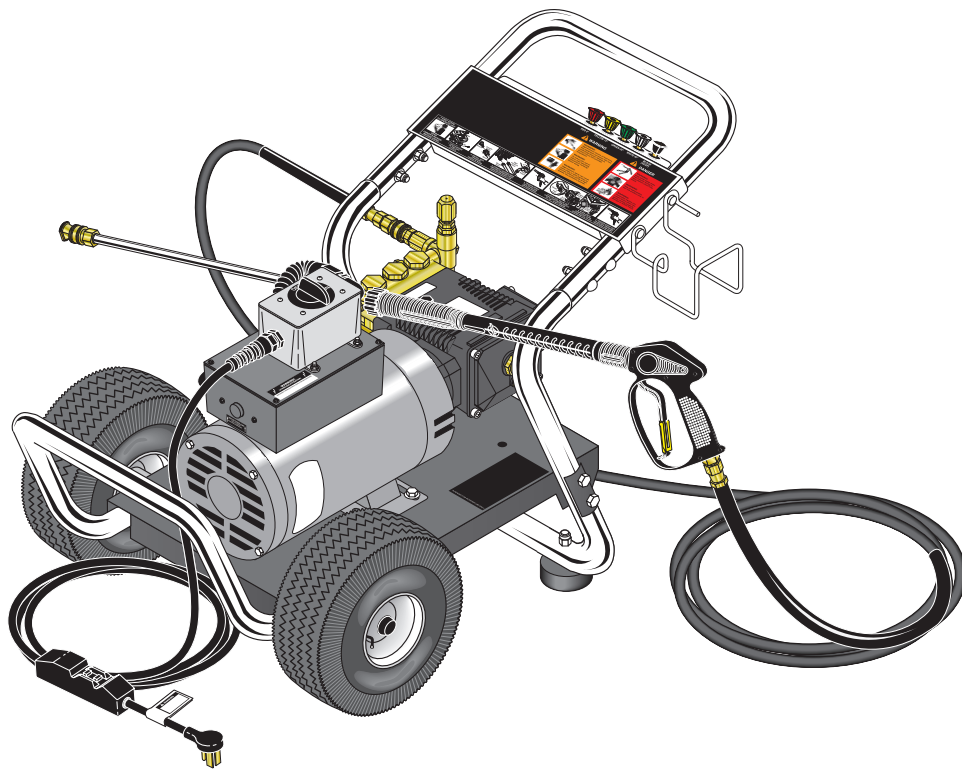

KÄRCHER®

OPERATOR'S MANUAL



<u>MODEL</u>	<u>ORDER #</u>	<u>MODEL</u>
HD 2.0/10 Ed	1.575-250.0	DE-201007D
HD 1.9/15 Ed	1.575-251.0	DE-201507D
HD 2.8/10 Ed	1.575-252.0	DE-301007D
HD 3.5/20 Ea	1.575-253.0	DE-352007A

To locate your local Kärcher Commercial Pressure Washer Dealer nearest you
visit www.karchercommercial.us

9.800-085.0

EXPLODED VIEW

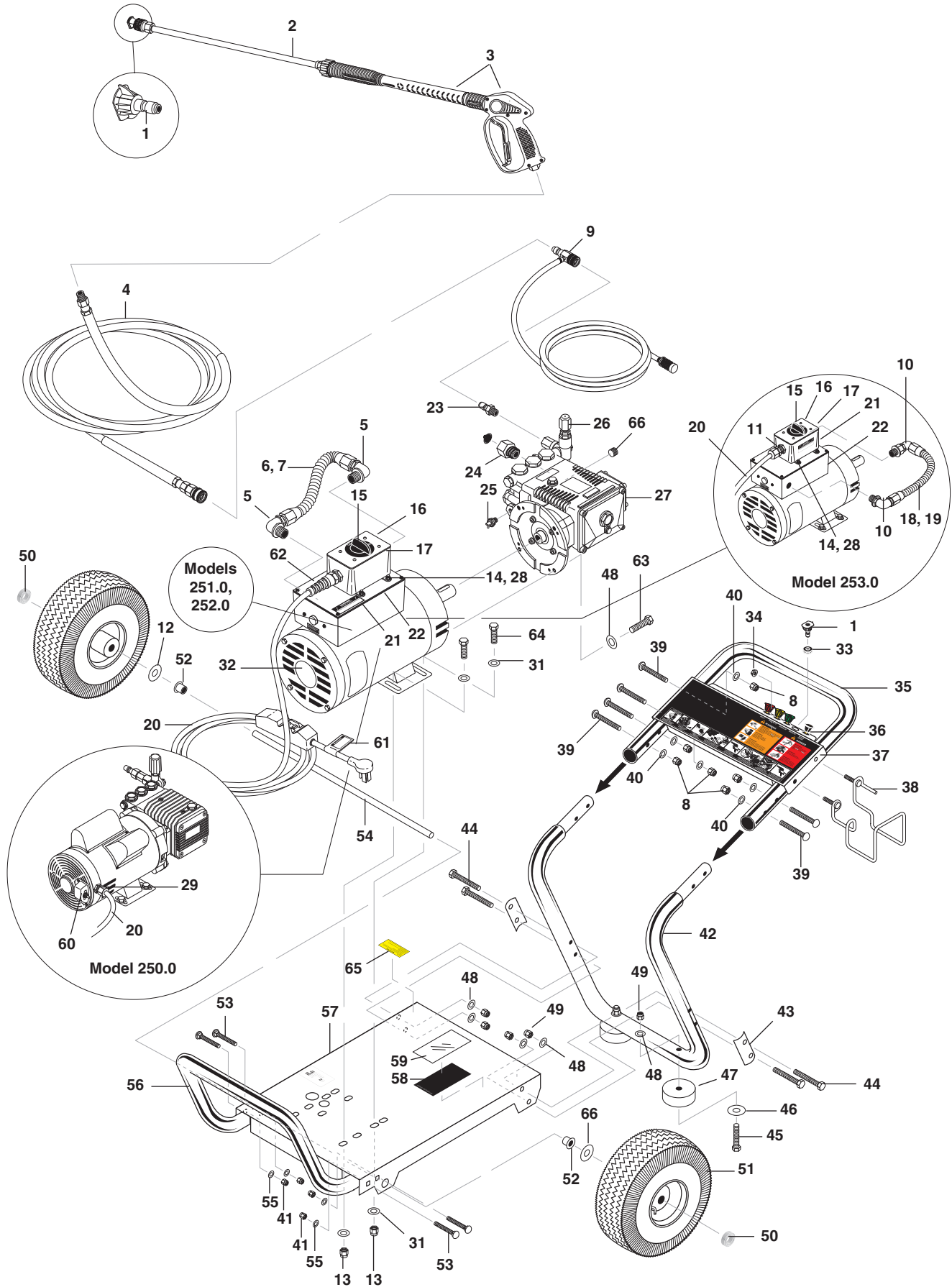

EXPLODED VIEW PARTS LIST

ITEM	PART NO.	DESCRIPTION	QTY
1	9.804-624.0	Nozzle, 150375, Yellow (251.0)	1
	9.804-625.0	Nozzle, 250375, Green (251.0)	1
	9.804-626.0	Nozzle, 400375, White (251.0)	1
	9.804-627.0	Nozzle, 000375, Red (251.0)	1
	9.802-296.0	Nozzle, 1504, Yellow (250.0)	1
	9.802-297.0	Nozzle, 2504, Green (250.0)	1
	9.802-298.0	Nozzle, 4004, White (250.0)	1
	9.802-295.0	Nozzle, 0004, Red (250.0)	1
	9.802-300.0	Nozzle, 1505, Yellow (253.0)	1
	9.802-301.0	Nozzle, 2505, Green (253.0)	1
	9.802-302.0	Nozzle, 4005, White (253.0)	1
	9.802-299.0	Nozzle, 0005, Red (253.0)	1
	9.802-304.0	Nozzle, 1555, Yellow (252.0)	1
	9.802-305.0	Nozzle, 2555, Green (252.0)	1
	9.802-306.0	Nozzle, 4055, White (252.0)	1
	9.802-303.0	Nozzle, 0055, Red (252.0)	1
	9.802-311.0	Nozzle, Compl. QCME 6540, Brass, All	1
2	9.802-220.0	Wand, 18" M22 x 1/4" QC	1
3	9.802-223.0	Spray Gun, SK@, 3/8" Inlet	1
4	Hose, See Specifications Page		
5	9.802-517.0	Connector, 1/2" L/T, 90°, Black (251.0, 252.0)	2
6	9.802-427.0	Cord, Service, SOWA 12/3, Coleman (251.0, 252.0)	21"
7	9.802-448.0	Conduit, Watertight, Flex, 1/2" (251.0, 252.0)	8"
8	9.802-773.0	Nut, 1/4" ESNA, NC	6
9	9.802-225.0	Injector, Detergent, Assy, 3-5 GPM	1
10	9.803-831.0	Connector, 3/4" L/T, 90°, Black (253.0)	2
11	9.802-518.0	Strain Relief, 3/4" (253.0)	1
	9.802-523.0	▲ Locknut, 3/4" (253.0)	1
12	9.802-810.0	Washer, 5/8" Flat	2
13	9.802-776.0	Nut, 5/16" ESNA	4
14	9.802-759.0	Screw, 10/32" x 1/2" BHSOC, Black (251.0, 252.0, 253.0)	4
15	9.802-450.0	Switch, 2 Pos. 120V-600V, 1-3 PH Brema (251.0, 252.0, 253.0)	1
16	9.802-478.0	Lid, Plastic, Carlon E9801 Box (251.0, 252.0, 253.0)	1
17	9.802-477.0	Box, Plastic, Carlon E9801, w/o Lid (251.0, 252.0, 253.0)	1
18	9.802-436.0	Cord, Service, 10/3 (253.0)	21"
19	9.803-832.0	Conduit, Water Tite, Flex 3/4" (253.0)	8"
20	9.802-430.0	GFCI, 240V1Ph30A, 36' 10-3 Cord (253.0)	1
	9.802-431.0	GFCI, 120V 20A, w/36' 12-3 Cord (251.0, 252.0)	1
	9.802-432.0	GFCI, 120V 15A, w/36' 12-3 Cord (250.0)	1
21	9.800-016.0	Label, Disconnect Power Supply	1

EXPLODED VIEW PARTS LIST

ITEM	PART NO.	DESCRIPTION	QTY
22	9.803-833.0	Cover, Motor (251.0, 252.0, 253.0)	1
23	9.802-171.0	Nipple 3/8" x 3/8" NPT Male	1
24	9.802-146.0	Swivel, 1/2" MP x 3/4" GHF, w/Strainer	1
25	9.802-182.0	Protector, Pump 1/2" 140°	1
26	Unloader, See Specifications Page		
27	Pump, See Specifications Page		
28	9.802-695.0	Nut, 10/32" Keps (251.0, 252.0, 253.0)	4
29	9.802-514.0	Strain Relief (250.0)	1
	9.802-525.0	▲ Locknut, 1/2" (250.0)	1
30	9.802-695.0	▲ Nut, 10/32" Keps (251.0, 252.0, 253.0)	3
	9.802-699.0	▲ Screw, 10/32" x 3/4" Slot Pan, MS, SS (251.0, 252.0, 253.0)	1
	9.800-040.0	▲ Label, Ground (251.0, 252.0, 253.0) (250.0)	2 1
31	9.802-804.0	Washer, 5/16" Flat	8
32	Motor, See Specifications Page		
33	9.802-064.0	Grommet, Rubber, Nozzle Holder	5
34	9.802-778.0	Nut, 5/16" Flange, Whiz Loc	2
35	9.803-122.0	Handle, Grab, Chrome	1
36	9.800-062.0	Label	1
37	9.803-120.0	Plate, Warning/Instr. Black	1
38	9.803-098.0	Hanger, Hose/Wand	1
39	9.802-706.0	Bolt, Carriage, 1/4"-20 x 1-3/4"	6
40	9.802-802.0	Washer, 1/4" Flat	6
41	9.802-776.0	Nut, 5/16" ESNA, NC	4
42	9.803-119.0	Handle, Lower Grab, Chrome	1
43	9.803-114.0	Retainer Bracket, Handle, Black	2
44	9.802-728.0	Bolt, 3/8" x 2"	4
45	9.802-729.0	Bolt, 3/8" x 2-1/4"	2
46	9.802-817.0	Washer, 3/8" x 1"	2
47	9.802-066.0	Pad, Soft Rubber, 50 Duro	2
48	9.802-807.0	Washer, 3/8" SAE, Flat	10
49	9.802-779.0	Nut, 3/8" ESNA, NC	6
50	9.802-783.0	Axle Hub Black	2
51	9.802-270.0	Wheel & Tire Assy., 4" Steel Rim w/Tube	2
52	9.802-103.0	Bushing, Snap, 5/8"	2
53	9.802-712.0	Bolt, Carriage 5/16" x 1-3/4"	4
54	9.803-097.0	Axle, 5/8" x 19.625" Long	1
55	9.802-804.0	Washer, 5/16" Flat, SAE	4
56	9.803-123.0	Handle, Bumper, Chrome	1
57	9.803-125.0	Base, CW Direct, Black	1
58	9.800-013.0	Label, Intended For Indoor Use	1
59	9.800-034.0	Label, Clear Lexan, 2-1/4" x 4-1/2"	1

EXPLODED VIEW PARTS LIST

ITEM	PART NO.	DESCRIPTION	QTY
60	9.802-454.0	Switch Assembly (250.0)	1
61	9.800-015.0	Label, Warning, Service Cord	1
62	9.802-516.0	Strain Relief, Flex 90°, Plastic (251.0, 252.0)	1
	9.803-834.0	▲ Washer, 3/4" x 1/2" Reducing (251.0, 252.0)	1
63	9.802-272.0	Bolt, 3/8" x 1" NC HH	4
64	9.802-709.0	Bolt, 5/16" x 3/4" NC, Grade 5	4
65	9.800-049.0	Label, Manufacturer's Cleaning Solution	1
66	9.803-051.0	Plug, 1/8" Counter Sunk	1

▲ Not Shown

HOSE AND SPRAY GUN ASSEMBLY

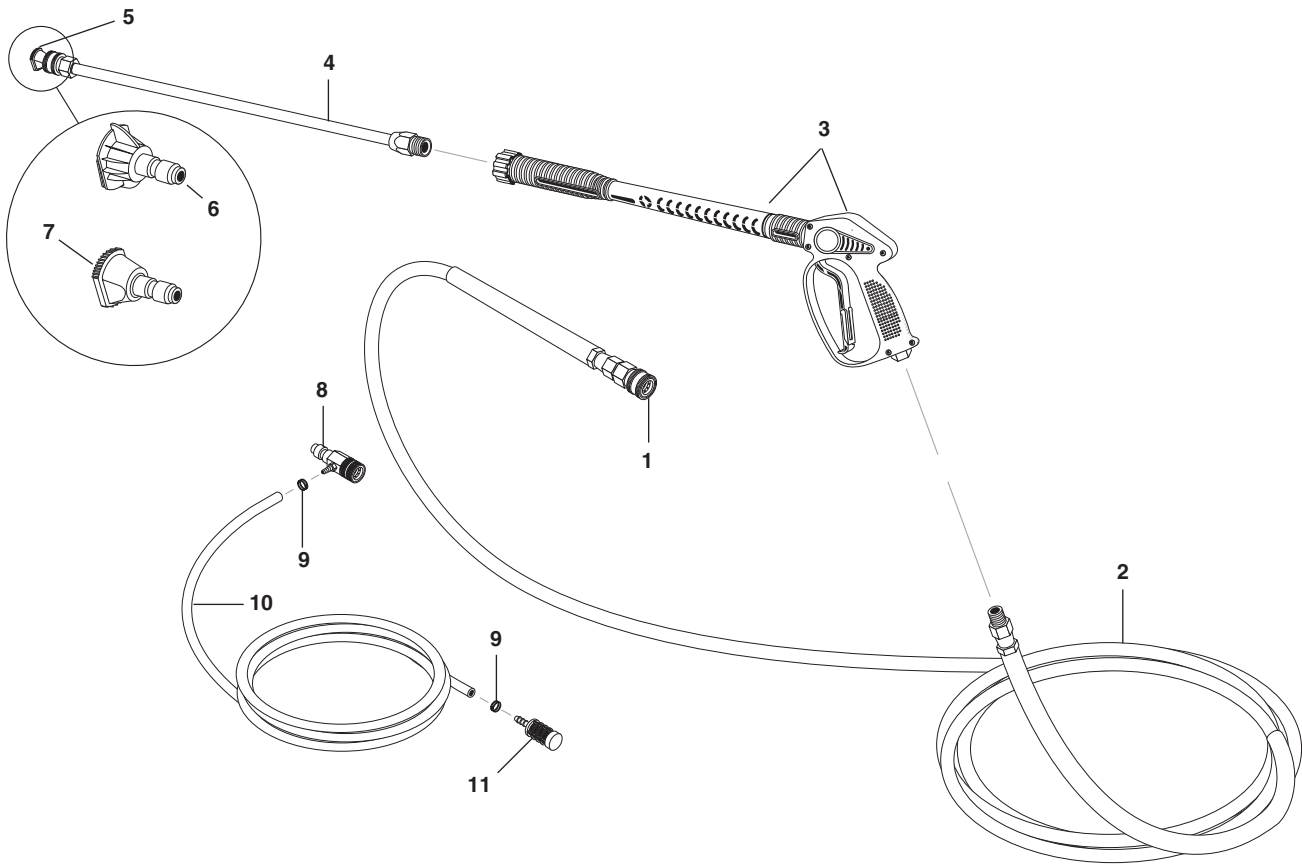

HOSE AND SPRAY GUN ASSEMBLY PARTS LIST

ITEM	PART NO.	DESCRIPTION	QTY
1	9.802-166.0	Coupler, 3/8" Female	1
	9.802-100.0	Quick Coupler O-Ring	1
2	8.739-125.0	Hose, 3/8" x 50', 1 Wire, Tuff-Flex	1
3	9.802-223.0	Spray Gun, Shut-Off	1
4	9.802-220.0	Wand, Straight	1
5	9.802-164.0	Coupler, 1/4" Female	1
	9.802-096.0	Quick Coupler O-Ring	1
6	Nozzle, See Page 13 For Size		
7	9.802-311.0	Nozzle, Brass Soap	1
8	9.802-216.0	Injector, Chemical, Non-Adjust, 3-5GPM, .083	1
9	9.802-210.0	Clamp, Hose, .46 - .54 ST	2
10	9.802-251.0	Tube, 1/2" x 1/2" Clear Vinyl	6 ft.
11	9.802-160.0	Strainer, 1/4" Hose Barb, Plastic	1

▲ Not Shown

VBA35 UNLOADER EXPLODED VIEW

8.715-463.0 KD 25 LPM @ 240 BAR
 9.803-900.0 KM 25 LPM @ 240 BAR

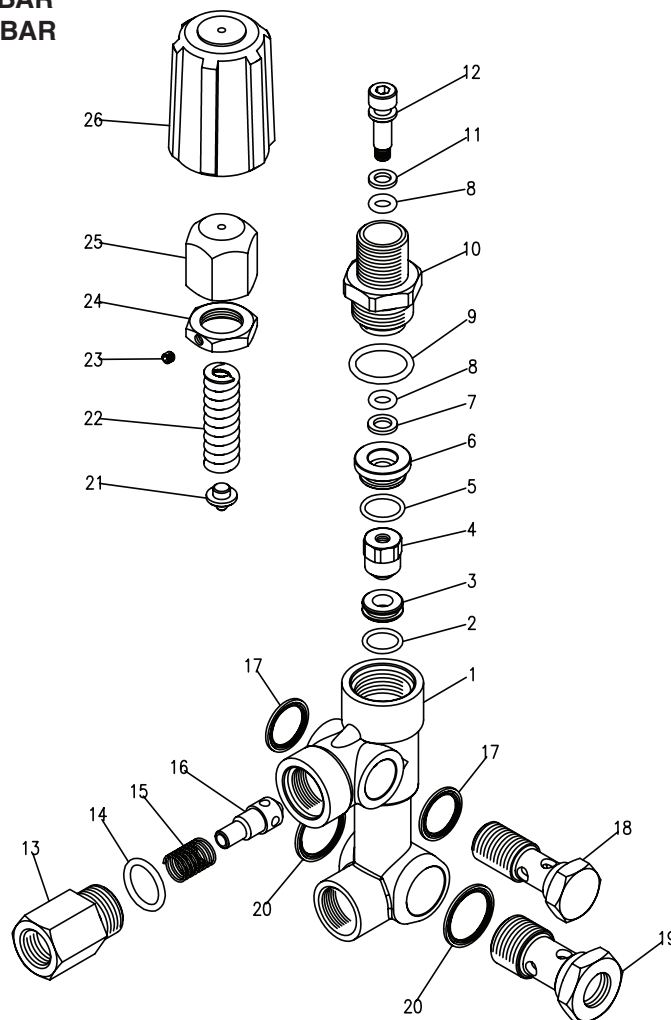

VBA35 UNLOADER EXPLODED VIEW PARTS LIST

ITEM	PART #	DESCRIPTION	KIT	QTY	ITEM	PART #	DESCRIPTION	KIT	QTY
1	9.803-901.0	Body Valve (KM)		1	15	9.803-916.0	Spring	B	1
	9.803-902.0	Body Valve (KD)		1	16	9.803-917.0	Poppet	B	1
2	9.803-903.0	O-Ring	A, C	1	17	9.802-893.0	Seal Washer 3/8		2
3	9.803-904.0	Seat	C	1	18	9.803-920.0	Banjo Bolt, 3/8 w/ 1/8 Pilot		1
4	9.803-905.0	Ball, Sub-assy	C	1	19	9.803-915.0	Banjo Bolt 1/2		1
5	9.803-906.0	O-Ring	A	1	20	9.803-921.0	Seal Washer 1/2		2
6	9.803-907.0	Guide Bushing		1	21	9.803-922.0	Plate	C	1
7	9.803-908.0	Teflon Ring	A	1	22	9.803-923.0	Spring	C	1
8	9.803-909.0	O-Ring	A	2	23	9.803-924.0	Set Screw		1
9	9.803-910.0	O-Ring	A	1	24	9.803-925.0	Nut		1
10	9.803-911.0	Connector		1	25	9.803-926.0	Brass Handle		1
11	9.803-912.0	Teflon Ring	A	1					
12	9.803-913.0	Stem	C	1	Kit A	9.803-927.0	O-Ring Repair Kit		
13	9.803-914.0	Connector, Female		1	Kit B	9.803-928.0	Outlet Kit		
14	9.803-191.0	O-Ring	A, B	1	Kit C	9.803-929.0	Stem Repair Kit		

KE SERIES PUMP EXPLODED VIEW

9.803-814.0 KE 2020F
 9.803-815.0 KE 2020S
 9.803-816.0 KE 2825F
 9.803-817.0 KE 2825S
 9.803-818.0 KE 3525F

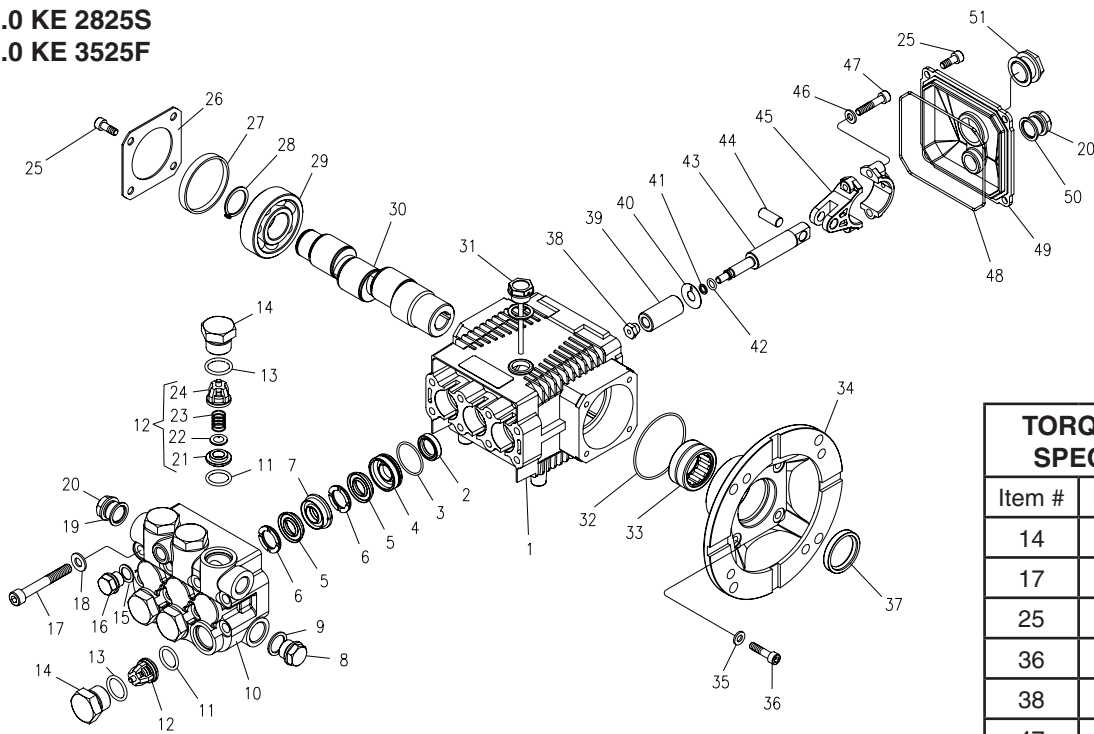

TORQUE SPECS	
Item #	Ft.-lbs
14	65
17	22
25	8
36	8
38	9
47	13

KE SERIES PUMP EXPLODED VIEW PARTS LIST

ITEM	PART NO.	DESCRIPTION	QTY	ITEM	PART NO.	DESCRIPTION	QTY
1	9.803-938.0	Crankcase	1	16	9.803-951.0	Brass Plug G1/4	1
2*	9.804-586.0	Plunger Oil Seal	3	17	9.803-952.0	Manifold Stud Bolt	8
3*	9.803-939.0	O-Ring Ø 1.78 x 28.30	3	18	9.802-884.0	Washer	8
4*	9.804-552.0	Pressure Ring 15mm	3	19	9.803-198.0	Copper Washer 3/8	1
	9.803-941.0	Pressure Ring 18mm	3	20	9.802-925.0	Brass Plug G3/8	2
5*	8.717-030.0	"V" Seal, dia 15mm	6	25	9.802-939.0	Screw	12
	9.804-575.0	"V" Seal, dia 18mm	6	26	9.803-953.0	Bearing Cover	2
6*	9.803-942.0	Support Ring 15mm	6	27	9.803-954.0	Bearing Seal	1
	9.803-943.0	Support Ring 18mm	6	28	9.802-914.0	Snap Ring	1
7*	9.803-944.0	Intermed Ring 15mm	3	29	9.803-955.0	Ball Bearing	2
	9.803-945.0	Intermed Ring 18mm	3	30	9.804-576.0	Crankshaft (2020F)	1
8*	9.802-926.0	Brass Plug G1/2	1		9.804-577.0	Crankshaft (2020S)	1
9	9.803-199.0	Copper Washer 1/2"	1		9.804-578.0	Crankshaft (2825F)	1
10	9.803-946.0	Manifold Housing	1		9.804-579.0	Crankshaft (2825S)	1
11	9.803-947.0	O-Ring Ø1.78 x 15.54	6		9.804-580.0	Crankshaft (3525F)	1
12*	See Kit Below	Valve Assembly	6	31	9.803-957.0	Oil Dipstick	1
13*	9.803-948.0	O-Ring Ø2.62 x 18.77	6	32	9.804-581.0	O-Ring Ø3.53 x 55.56	1
14	9.803-949.0	Valve Plug	6	33	9.804-582.0	Needle Bearing	1
15	9.803-950.0	Copper Washer 1/4	1	34	9.804-583.0	Motor Flange 56C	1

KE SERIES PUMP EXPLODED VIEW PARTS LIST

ITEM	PART NO.	DESCRIPTION	QTY
35	9.803-210.0	Washer	4
36	9.804-584.0	Flange Screw	4
37	9.804-585.0	Crankshaft Seal	1
38*	9.803-959.0	Plunger Nut	3
39*	9.803-960.0	Plunger 15mm (2020F, 2825F, 3525F)	3
	9.803-961.0	Plunger 18mm (2020S, 2825S)	3
40*	9.803-962.0	Copper Spacer	3
41*	9.802-928.0	O-Ring Ø1.78 x 5.28	3
42*	9.803-156.0	Teflon Ring	3
43	9.803-964.0	Plunger Rod	3
44	9.803-965.0	Connecting Rod Pin	3
45	9.803-966.0	Connecting Rod	3
46	9.803-218.0	Spring Washer	6
47	8.933-020.0	Connecting Rod Screw	6
48	9.803-969.0	O-Ring Ø2.62 x 107.62	1
49	9.803-968.0	Crankcase Cover	1
50	9.803-197.0	Gasket	1
51	9.803-202.0	Sight Glass	1

Repair Kit Number	9.803-930.0	9.803-931.0	9.803-932.0	9.803-933.0	9.803-934.0	9.803-935.0	9.803-936.0	9.803-937.0
Kit Description	Plunger Seal KE 2020F KE 2825F KE 3525F	Plunger Seal 18mm KE 2020S KE 2825S	Complete Seal Packing 15mm KE 2020F KE 2825F KE 3525F	Complete Seal Packing 18 mm KE 2020S KE 2825S	Plunger 15mm KE 2020F KE 2825F KE 3525F	Plunger 18mm KE 2020S KE 2825S	Complete Valve	Plunger Oil Seals
Item Numbers Included	3, 5, 6	3, 5, 6	2, 3, 4, 5, 6, 7	3, 4, 5, 6, 7, 8	38, 39, 40, 41, 42	38, 39, 40, 41, 42	11, 12, 13	2
Number Of Cylinders Kit Will Service	3	3	1	1	1	1	6	3

SPECIFICATIONS

Machine Model	GPM	Pressure (PSI)	Nozzle Size	Hose p/n	Pump Part #	Pump Model	Unloader Part #	Motor Hp	Motor Part #
1.575-250.0	2.0	1000	3.75	9.802-233.0	9.803-814.0	KE2020F	8.715-463.0	1-1/2	9.802-338.0
1.575-251.0	1.9	1500	3.0	9.802-233.0	9.803-814.0	KE2020F	8.715-463.0	2	9.802-339.0
1.575-252.0	2.8	1000	5.5	9.802-233.0	9.803-816.0	KE-2825-F	8.715-463.0	2	9.802-339.0
1.575-253.0	3.5	2000	5.0	9.802-233.0	9.803-818.0	KE-3525-F	8.715-463.0	5	9.802-341.0