

SERVICE MANUAL

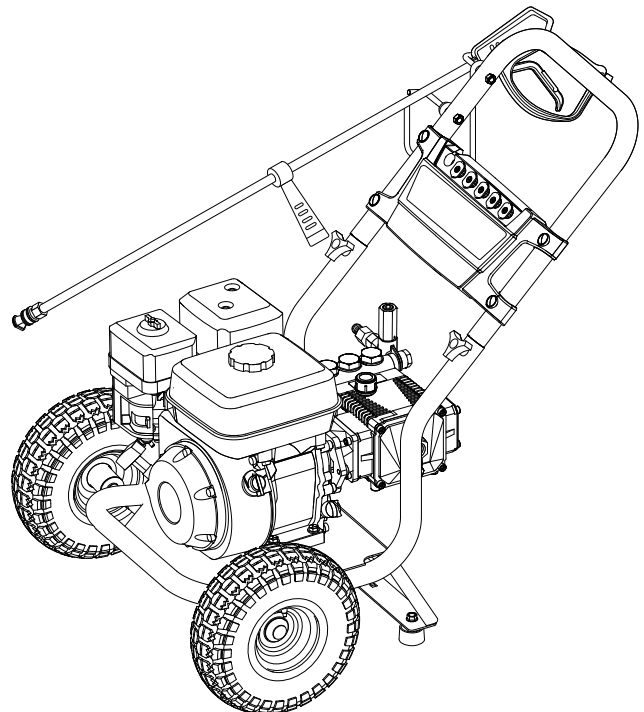
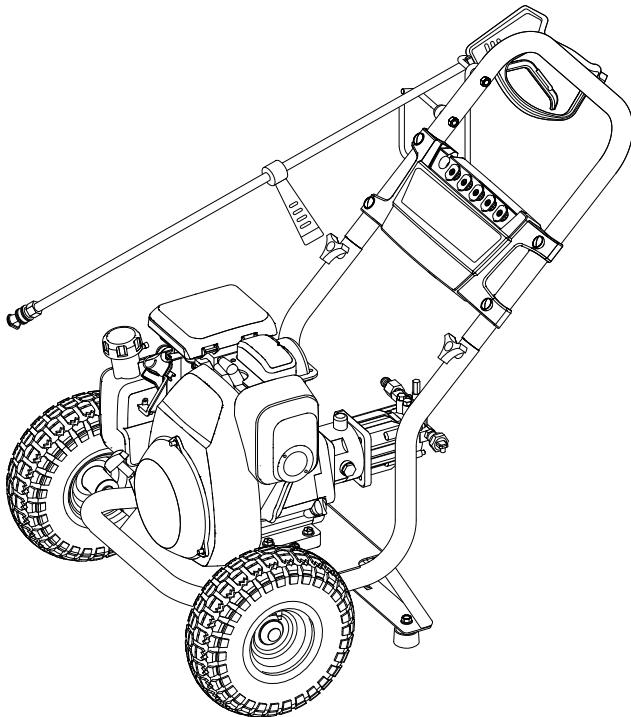

MODEL #	ORDER #
XPERT-HD 2.3/23 P / DD-232336	1.107-103.0
XPERT-HD 2.3/23 P / DD-232337	1.107-104.0
XPERT-HD 2.5/27 P / DD-252737	1.107-106.0
PD3-23326	1.107-091.0
PD3-23327	1.107-092.0
PD3-27324	1.107-094.0
DA-232336	1.107-097.0
DA-232337	1.107-098.0
DA-252739	1.107-100.0

CONTENTS

Exploded View	4
Exploded View Parts List	5-6
BXD Comet Pump and Repair Kits.....	7
Legacy Axial Pump.....	8-9
G.1 Pump w/3/4" Hollow Shaft Exploded and Parts List.....	10-11
UU1 Universal Unloader Exploded and Parts List	12
Troubleshooting	13-14
Preventive Maintenance	15
Oil Change Record	16

EXPLODED VIEW

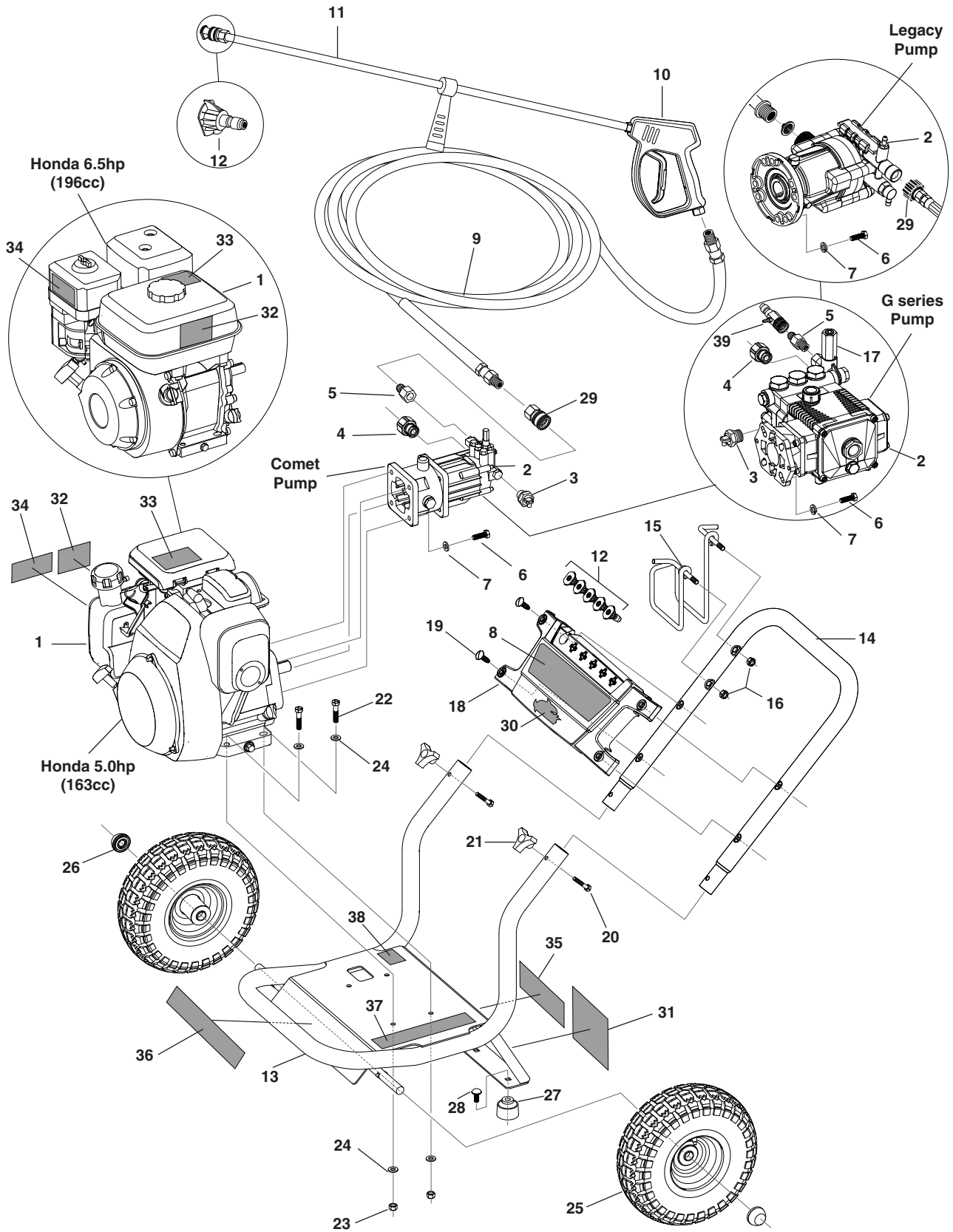

EXPLODED VIEW PARTS LIST

ITEM	PART NO.	DESCRIPTION	QTY
1	9.194-015.0	Engine -Honda GC 160 QHA , 5.0 HP (163cc/5.0HP)-(Legacy & Comet Pump Models)	1
	9.802-317.0	Engine, Honda, GX200UTQX2, 6.5 HP (196cc/6.5HP Models)	1
2	(see page 7)	Comet Pump BXD Assy	1
	(see page 8)	Pump, Legacy Axial 2.6 GPM 3000PSI	1
	(see page 10)	G.1 Series Pump, 2.5 @3000, 3400 RPM (196cc/6.5HP Models)	1
3	8.707-256.0	Pump protector,1/2" PTP, 140DEG,P/N 1005 (All Models Except Legacy Pump Models)	1
4	9.802-146.0	Swivel, 1/2" MP X 3/4", GHF w/strainer (All Models Except Legacy Pump Models)	1
5	9.802-170.0	Nipple, 3/8" X 3/8", NPT ST Female (Comet Pump Models)	1
	9.802-171.0	Nipple, 3/8" X 3/8", NPT ST Male (196cc/6.5HP Models)	1
6	6.965-007.0	5/16"-24X1" GR 5 SHCS THRU Hardener ZC	4
7	9.802-813.0	Washer, 5/16", Lock, Split Ring	4
8	9.138-437.0	Karcher branding label (Xpert HD & DD Models)	1
	9.138-439.0	Landa branding label (PD Models)	1
	9.138-440.0	Hotsy branding label (DA Models)	1
9	8.739-133.0	Hose, 3/8" X 25' 1 Wire Tuff-Skin (5 HP PD Models)	1
	8.739-026.0	Hose, 3/8" X 50' 1 Wire Tuff-Skin (6.5 HP PD Models)	1
	8.739-106.0	Hose, 3/8" X 25' 1 Wire Tuff-Skin (5 HP DA Models)	1
	8.739-011.0	Hose, 3/8" X 50' 1 Wire Tuff-Skin (6.5 HP DA Models)	1
	8.739-124.0	Hose, 3/8" X 25' 1 Wire Tuff-Skin (5 HP Xpert & DD Models)	1
	8.739-021.0	Hose, 3/8" X 50' 1 Wire Tuff-Skin (6.5 HP Xpert and DD Models)	1
10	8.750-247.0	Gun, M407	1
11	8.783-039.0	Wand, 30"	1
12	9.104-024.0	Quick connect nozzle Kit(030)	1
	▲9.802-287.0	Nozzle, 0003, Red	1
	▲9.802-288.0	Nozzle, 0015, Yellow	1
	▲9.802-289.0	Nozzle, 0025, Green	1
	▲8.932-998.0	Nozzle, 0040, White	1
	▲9.802-311.0	Nozzle, Black, Soaper	1
13	9.115-095.0	Frame O4-BLK Wrinkle	1
14	9.140-131.0	Handle BLK Wrinkle	1
15	9.142-014.0	Hanger RT side	1
16	9.802-778.0	Nut, 5/16" Whiz Loc Flange	2
17	(see page 12)	UU1, 3500PSI, Universal Unloader (196cc/6.5HP Models)	1
18	9.134-022.0	Name plate	1
19	9.196-049.0	Nylon Rivet	4
20	9.196-307.0	1/4"-20 x 1-1/2" GR 2, Hex Bolt Zinc	2
21	8.767-003.0	1/4"-20 Star Knob	2
22	9.802-713.0	Bolt, 5/16" X 1-1/2", NC HH(612975)	4
23	9.802-776.0	Nut, 5/16", ESNA, NC	4
24	8.718-980.0	Washer, 5/16", Flat, SAE(780452)	8
25	9.189-007.0	Wheel 10" X 3.50" Pneu	2
26	9.182-506.0	Cap Black Plastic, 5/8"Fastener	2
27	9.183-405.0	Rubber dampener	2
28	9.196-308.0	5/16"-18 X 1/2" Carriage Bolt, A307 BLK	2
29	9.802-166.0	Coupler, 3/8" Female, Brass	1
	▲8.702-088.0	O-Ring, Viton, 3/8"	1
	8.707-182.0	Coupler, Twist Connect, M22-Fx3/8" FNP (Legacy Pump Models)	1
	▲8.704-036.0	O-Ring, Viton, Twist Connect	1
30	9.138-438.0	Shark branding label (Xpert HD & DD Models)	1

EXPLODED VIEW PARTS LIST (CONT)

ITEM	PART NO.	DESCRIPTION	QTY
31		Label, Intended for Outdoor Use - Serial - Specs	1
32	9.800-008.0	Label, Danger Cool Engine	1
33	9.800-006.0	Label, Hot/Caliente w/Arrows	1
34	8.917-015.0	Label Regulation 4442.6	1
35	8.783-034.0	Label, Quick Start Guide 1 (196cc/6.5HP Models)	1
	8.783-037.0	Label, Quick Start Guide 2 (163cc/5.0HP)-(Legacy & Comet Pump Models)	1
36	8.783-035.0	Label, Operator Warnings Trilingual	1
37	8.783-036.0	Label, Warning Pictogram	1
38	8.783-038.0	Label, Universal DB Rating, Ear Protection, Trilingual	1
39	9.802-215.0	Injector, Chem, Non Adj, 2-3 GPM, 0.070 (196cc/6.5HP Models)	1
40	6.388-216.0	▲ Hose DN 5	1
41	5.731-609.0	▲ Filter with weigh	1
42	9.802-958.0	▲ Shaft Key, 0.185 SQR X 1.75" (All Models Except Comet Pump Models)	1
		▲ Not Shown	

COMET PUMP BXD, 5/8" SHAFT EXPLODED VIEW

8.920-017.0 COMET PUMP BXD

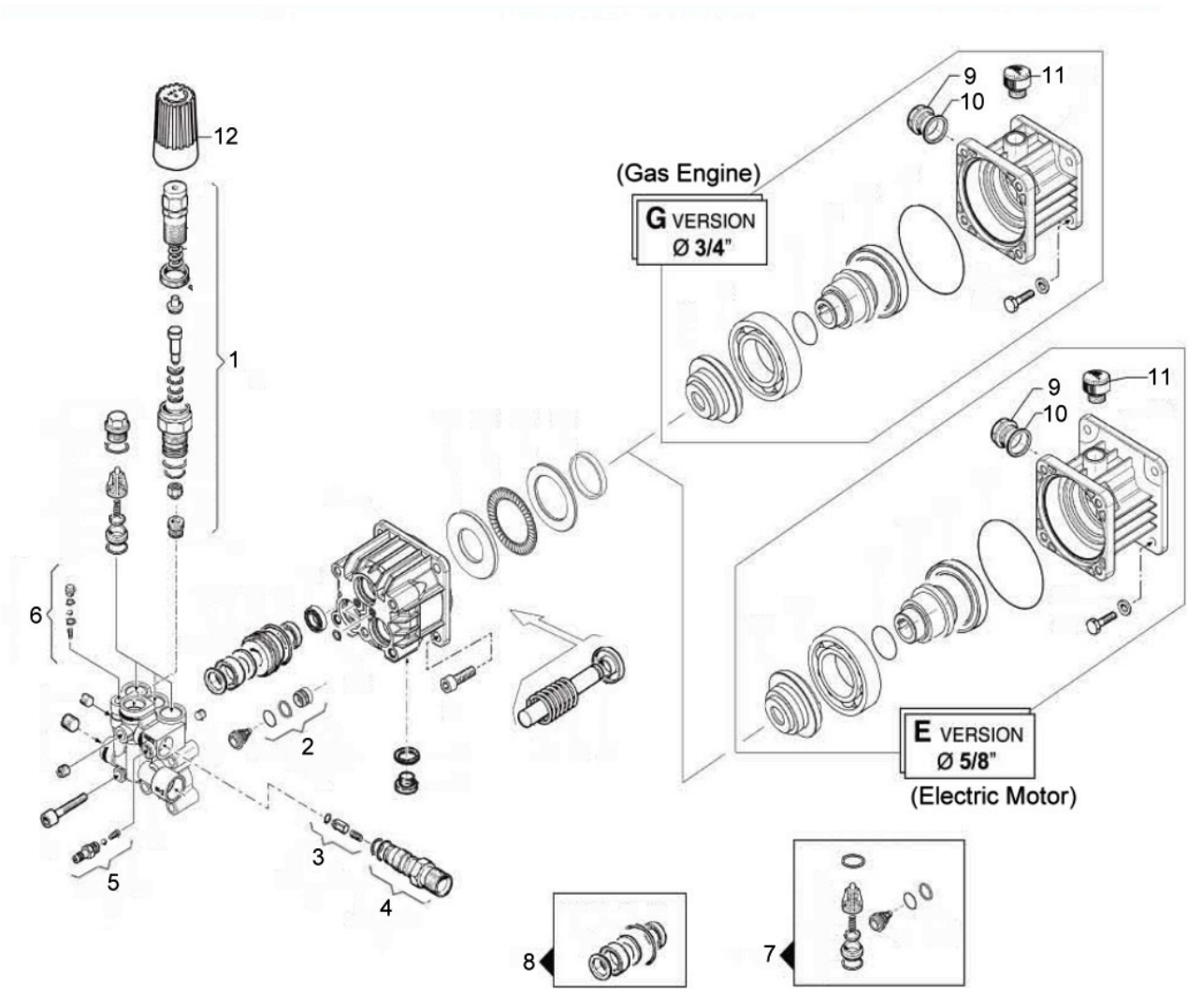

COMET PUMP BXD REPAIR KITS

ITEM	PART NO.	DESCRIPTION	QTY	ITEM	PART NO.	DESCRIPTION	QTY
1	8.725-556.0	Kit, valve	1	7	8.725-562.0	Kit, complete valve kit	1
2	8.725-557.0	Kit, suction valve	1	8	8.725-563.0	Kit, piston seal	1
3	8.725-558.0	Kit, check valve	1	9	8.725-564.0	Oil site glass	1
4	8.725-559.0	Kit, injector body	1	10	8.725-565.0	O´ring	1
5	8.725-560.0	Kit, chemical coupling	1	11	8.725-566.0	Oil cap	1
6	8.725-561.0	Kit, easy start	1	12	8.725-567.0	Knob	1

PUMP EXPLODED VIEW AND PARTS LIST

8.920-004.0

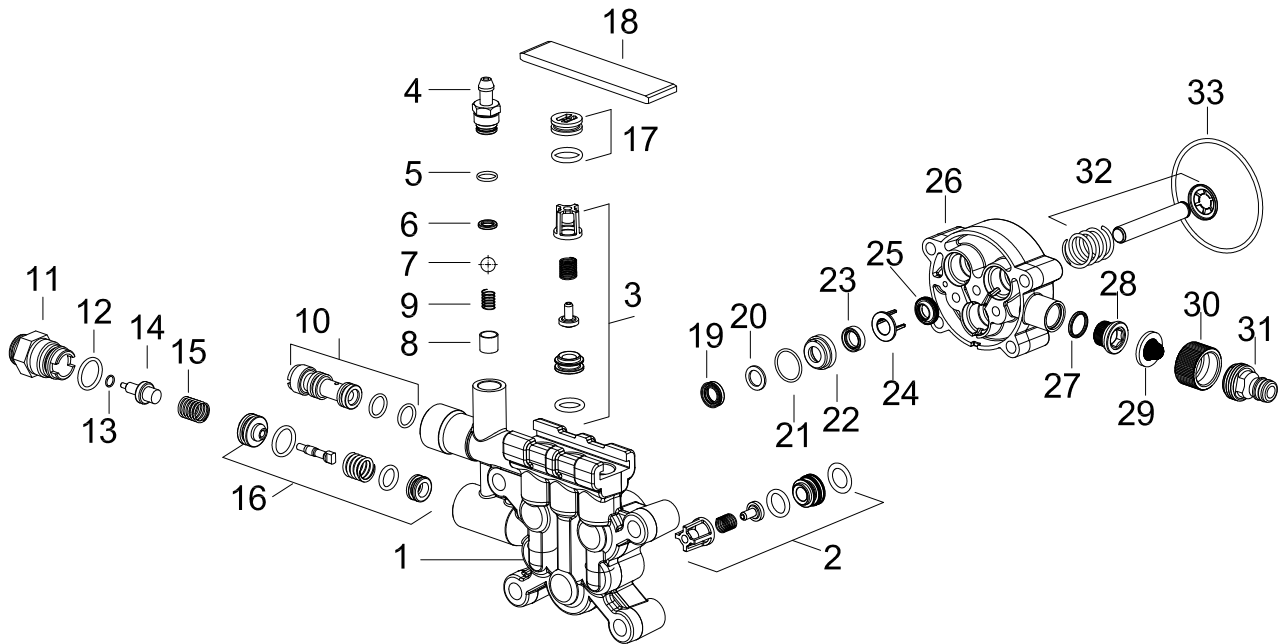

ITEM	PART #	DESCRIPTION	QTY
1	8.762-010.0	Cylinder Head	1
2	9.175-004.0	Valve Assy Horizontal	3
3	9.139-371.0	Spare Part List, Set 3	1
4	5.443-448.0	Nipple Chemistry	1
5	6.362-451.0	O-Ring Seal 8.0 x 1.0	1
6	6-362-175.0	O-Ring Seal, 5.28 x 1.78	1
7	7.401-909.0	Sphere 7 G40 - 1.4401	1
8	5.110-714.0	Sleeve	1
9	5.332-258.0	Helical Spring	1
10	9.139-372.0	Nozzle, INS 020/021 Pump	1
11	9.184-018.0	Outlet-Thermal Valve	1
12	6.362-480.0	O-Ring Seal, 12.42 x 1.78	1
13	7.362-507.0	O-Ring Seal 8 x 2 NBR 90	1
14	6.413-403.0	Thermo Valve Tin Coated	1

ITEM	PART #	DESCRIPTION	QTY
15	5.332-290.0	Helical Spring	1
16	9.175-005.0	Unloader Assembly	1
17	4.132-007.0	Drain Plug Replacement	1
18	5.003-062.0	Plate	1
19	9.177-301.0	Hich Pressure Seal	3
20	9.177-310.0	Back Ring	3
21	6.362-833.0	O-Ring Seal 12.5 x 1.73	3
22	9.155-011.0	Housing Low Pressure Seal	3
23	6.363-058.0	Grooved Ring	3
24	9.134-016.0	Spacer	3
25	6.365-393.0	Oil Sealing 12.20x4/6	3
26	9.133-007.0	Piston Guide	1
27	6.362-390.0	O-Ring Seal 15.6 x 1.8	1
28	9.134-019.0	Male Adapter	1
29	9.181-005.0	Filter Seal	1
30	9.155-013.0	Female House Conn	1
31	9.178-005.0	Adapter Garden	1
32	9.139-370.0	Spare Part List, Piston	1
33	6.362-471.0	O-Ring Seal 80.0x3.0 NBR70	1

PUMP EXPLODED VIEW PARTS LIST (CONT)

8.920-004.0 Housing View

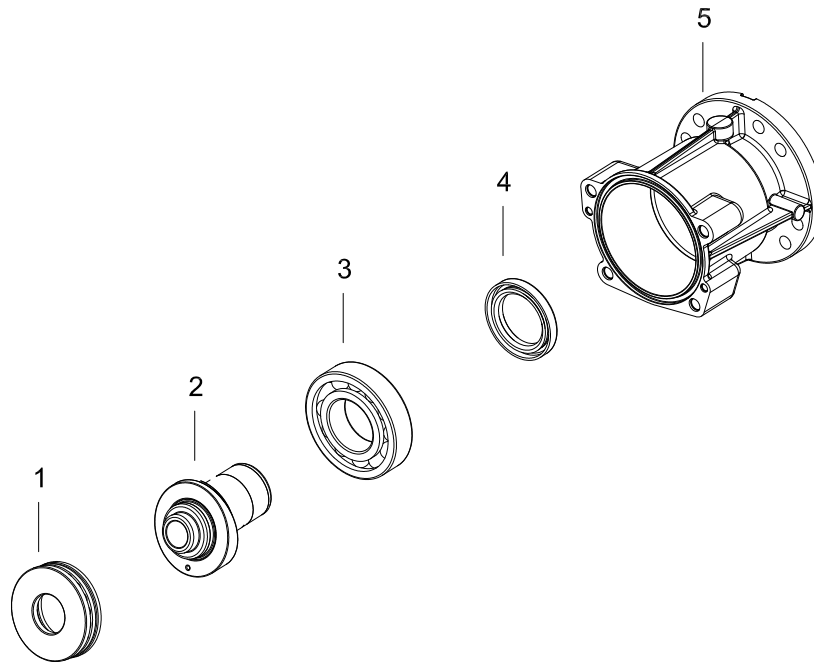

ITEM	PART #	DESCRIPTION	QTY
1	9.166-016.0	Grooved Ball Bearing	1
2	9.135-018.0	Swash Plate Hor.	1
3	9.165-356.0	Ball Bearing No 6207	1
4	9.177-314.0	Radial Seal 35 x 52 x 7	1
5	9.135-016.0	Oil Housing	

G.1 SERIES PUMP w/3/4" HOLLOW SHAFT EXPLODED VIEW

9.804-033.0 KG2530G.1

8.904-893.0 LG2530G.1

8.904-748.0 HG2530G.1

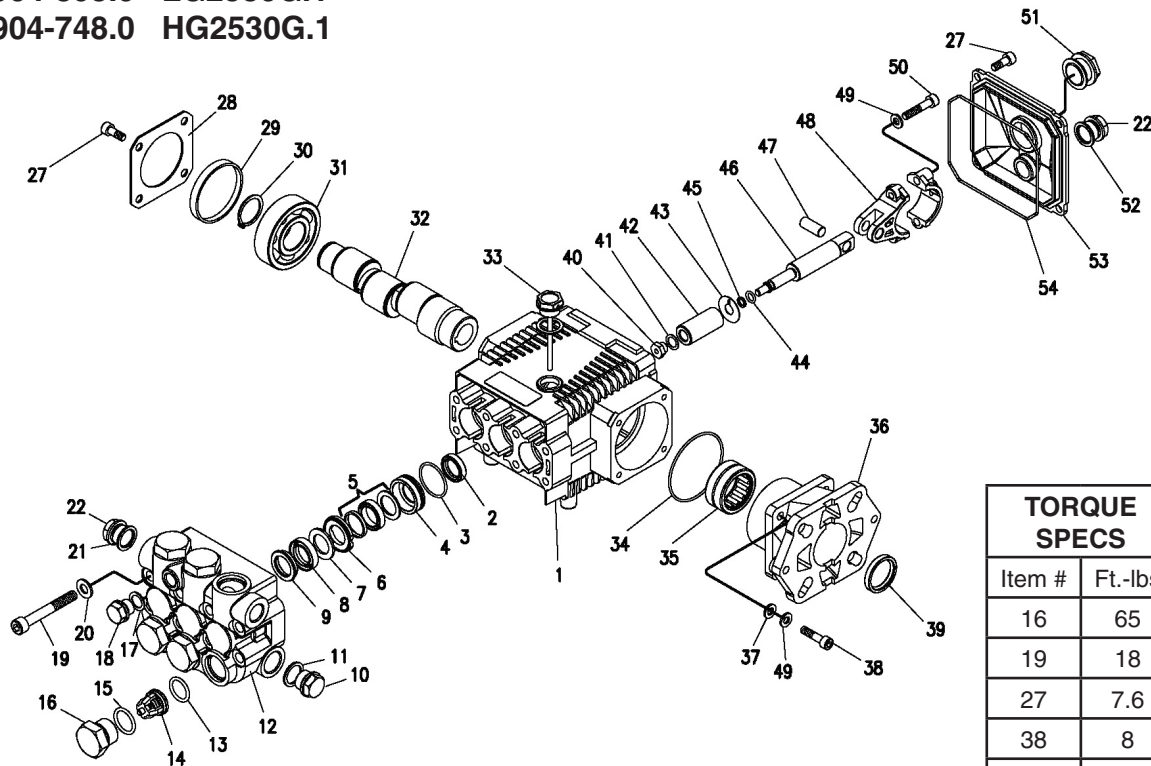

TORQUE SPECS	
Item #	Ft.-lbs
16	65
19	18
27	7.6
38	8
40	7
50	13

G.1 SERIES PUMP EXPLODED VIEW PARTS LIST

ITEM	PART NO.	DESCRIPTION	QTY	ITEM	PART NO.	DESCRIPTION	QTY
1	9.803-938.0	Crankcase	1	19	9.803-952.0	Manifold Stud Bolt	8
2*	See Kit Below	Plunger Oil Seal	3	20	9.802-884.0	Washer	8
3*	See Kit Below	O-Ring Ø1.78 x 28.30	3	21	9.803-198.0	Copper Washer 3/8"	1
4*	See Kit Below	Pressure Ring, 15mm	3	22	9.802-925.0	Brass Plug 3/8"	2
5*	See Kit Below	U-Seal, 15mm	3	27	9.802-939.0	Hexagonal Screw	9
6*	See Kit Below	Intermediate Ring 15mm	3	28	9.803-953.0	Bearing Cover	1
7*	See Kit Below	Backup Ring 15mm	3	29	9.803-954.0	Seal Bearing	1
8*	See Kit Below	U-Seal, 15mm	3	30	9.802-914.0	Snap Ring	1
9*	See Kit Below	Support Ring, 15mm	3	31	9.803-955.0	Ball Bearing	1
10	9.802-926.0	Brass Plug, 1/2"	1	32	8.717-069.0	Crankshaft (2530G)	1
11	9.803-199.0	Copper Washer 1/2"	1	33	9.803-957.0	Oil Dip Stick	1
12	9.803-946.0	Manifold Housing	1	34	9.804-581.0	O-Ring 3.53 x 55.56	1
13*	9.803-947.0	O-Ring Ø1.78 x 15.54	6	35	9.804-582.0	Needle Roller Bearing	1
14*	See Kit Below	Valve Assembly	6	36	8.717-212.0	Engine Flange	1
15*	9.803-948.0	O-Ring Ø2.62 x 18.77	6	37	9.803-210.0	Spring Washer	4
16	9.803-949.0	Valve Plug	6	38	9.804-584.0	Flange Screw	4
17	9.803-950.0	Washer, Copper	1				
18	9.803-951.0	Brass Plug G1/4	1				

G.1 SERIES PUMP EXPLODED VIEW PARTS LIST (CONT)

ITEM	PART NO.	DESCRIPTION	QTY
39	9.804-585.0	Crankshaft Seal	1
40*	See Kit Below	Plunger Nut	3
41*	See Kit Below	Copper Spacer	3
42*	See Kit Below	Plunger, 15mm	3
43*	See Kit Below	Copper Spacer	3
44*	See Kit Below	O-Ring Ø1.78x5.28	3
45*	See Kit Below	Teflon Ring	3
46	9.803-964.0	Plunger Rod	3
47	9.803-965.0	Connecting Rod Pin	3
45	9.803-966.0	Connecting Rod	3
49	9.803-218.0	Spring Washer	6
50	8.933-020.0	Connecting Rod Screw	6
54	9.803-969.0	O-Ring 2.62 x 107.62	1
53	9.803-968.0	Crankcase Cover	1
52	9.803-197.0	Gasket, G3/4	1
51	9.803-202.0	Sightglass G3/4	1

* Part available in kit (See below)

G.1 SERIES PUMP REPAIR KITS

REPAIR KIT NUMBER	8.725-354.0	8.725-355.0	9.803-934.0	9.803-936.0	9.803-937.0
KIT DESCRIPTION	Plunger Seal 15mm	Complete Seal Packing 15mm	Plunger 15mm	Complete Valve	Plunger Oil Seals
ITEM NUMBERS INCLUDED	3, 5, 7, 8, 9	3, 4, 5, 6, 7, 8, 9	40, 41, 42, 43, 44, 45	13, 14, 15	2

UU1 UNLOADER EXPLODED VIEW

9.175-018.0

UU1 3500PSI, UNIVERSAL UNLOADER (SPARE)

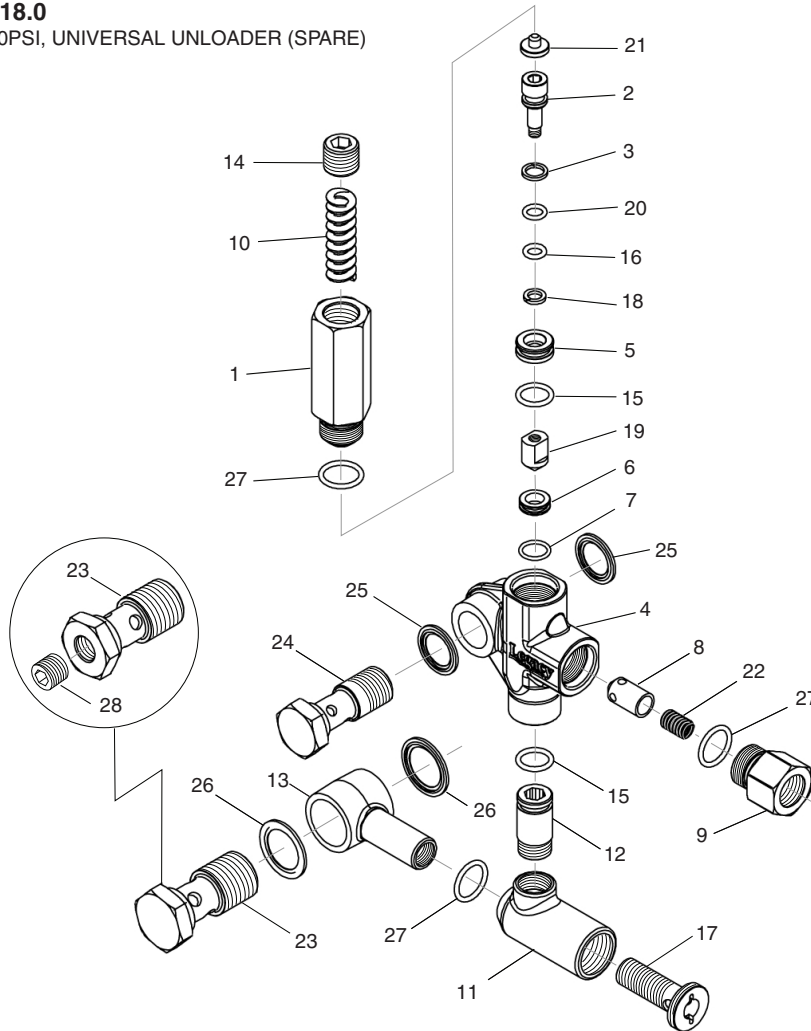

UU1 UNLOADER EXPLODED VIEW PARTS LIST

ITEM	PART #	DESCRIPTION	KIT	QTY	ITEM	PART #	DESCRIPTION	KIT	QTY
1	8.749-792.0	Piston housing		1	17	9.149-006.0	Sliding connector guide		1
2		Piston	C	1	18		O-ring backup 6X 1.45X 1.68	A	1
3		Piston O-ring back up	A	1	19		Conical seal	C	1
4	8.749-796.0	Main block		1	20		O-ring 6.75 X 1.78 BN80	A	1
5	9.152-372.0	Piston ring		1	21		Spring seat	C	1
6		Ball seat	C	1	22		Plunger spring	B	1
7		O-ring 10.5 ID X 1.5 CS	A,C	1	23	8.762-001.0	Banjo bolt 1/2"		1
8		Plunger	B	1		8.762-011.0	Banjo bolt 1/2"-1/4"NPT		1
9	9.152-016.0	Plunger housing		1		8.762-000.0	Banjo bolt 3/8"		1
10		Bypass spring	C	1	24	8.762-000.0	Banjo bolt 3/8"		1
11	9.149-001.0	Low pressure port		1	25	9.802-893.0	Seal washer 3/8"		2
12	9.152-017.0	Sliding connector, 30mm		1	26	9.803-921.0	Seal washer 1/2"		2
	8.762-005.0	Sliding connector, 40mm, long		1		9.802-893.0	Seal washer 3/8"		2
13	9.149-002.0	Sliding connector H 1/2"		1	27		O-RING 15 ID x 2CS	A,B	3
	9.149-005.0	Sliding connector H 3/8"		1	28	8.706-865.0	Plug, 1/4" countersunk		1
14	9.196-011.0	Plug 5/8 -18 UNF		1	Kit A	9.104-038.0	O-ring Repair Kit		
15		O-ring 12 ID x 2 CS	A	2	Kit B	9.104-039.0	Outlet Kit		
16		O-ring 6 ID X 2 CS	A	1	Kit C	9.104-040.0	Stem Repair Kit		

TROUBLESHOOTING

PROBLEM	POSSIBLE CAUSE	SOLUTION
LOW OPERATING PRESSURE	Insufficient water supply. Closed faucet. Inlet hose kinked	Use larger garden hose; clean inlet water screen. Open faucet.
	Clogged inlet hose strainer	Check plumbing system for leaks. Retape leaks with teflon tape.
	Faulty or mis-adjusted unloader valve	Adjust unloader for proper pressure. Install repair kit when needed. Call local distributor.
	Worn packing in pump	Call Dealer Customer Support.
	Machine has been stored in freezing temperatures	Thaw out machine completely, including hose, spray gun and wand.
	Slow engine RPM	Call local distributor.
FLUCTUATING PRESSURE	Worn or dirty pump valves	Call local distributor.
	Nozzle is obstructed	Blow out or remove debris with fine needle.
	Pump sucking air, inlet hose leaking	Check that all hoses and fittings are airtight. Turn off machine and trigger spray gun until a steady flow of water emerges through the nozzle.
	Insufficient water supply	Turn water on full force. Check garden hose for kinks, leaks or blockage.
PRESSURE LOW AFTER PERIOD OF NORMAL USE	Nozzle worn	Replace nozzle.
	Unloader valve worn	Replace unloader valve.
ENGINE WILL NOT START OR STOPS WHILE OPERATING	Low oil shutdown	Fill engine with oil.
	Out of gas	Fill fuel tank.
	Water in gasoline	Drain gas tank; fill with clean fuel.
ENGINE IS OVERLOADED	Nozzle partially blocked	Clean nozzle.
	Excessive pressure from high engine RPM	Adjust engine throttle to lower RPM.
WATER OR OIL LEAKING FROM BOTTOM OF PUMP	A small amount of leaking is normal	If excessive leaking occurs, Call local distributor.
PRESENCE OF WATER IN PUMP OIL (BXD Comet & G Pump Series Only)	Water sprayed at machine	Change oil. Direct spray away from machine.
	High humidity in air	Check and change oil twice as often.
	Piston packing worn. Oil seal worn.	Call local distributor.

TROUBLESHOOTING

PROBLEM	POSSIBLE CAUSE	SOLUTION
ENGINE OPERATES FOR 15 MINUTES THEN STOPS	Not enough gas or engine oil	Fill tank with gas. Check oil level.
	Vapor lock developed by heat of day	Keep gas tank full to avoid vapor locking.
	Obstruction in fuel filter	Clean or replace fuel filter.
ENGINE LACKS POWER	Dirty air filter	Replace air filter.
ENGINE FALTERS	Choke is opened too soon	Move choke to halfway position until engine runs smoothly.
WATER DRIPPING FROM UNDER PUMP	Piston packing worn	Call local distributor.
	O-Ring plunger retainer worn	Call local distributor.
	Cracked piston	Call local distributor.
OIL DRIPPING	Oil seal worn or damaged	Call local distributor.
WATER LEAKING FROM PUMP PROTECTOR	Spray gun closed with machine running 5 minutes or longer	Open spray gun or turn off machine.
	Excess water supply pressure	Place a pressure regulator at end of 50' garden hose.
NO DETERGENT	Detergent suction tube not properly connected to machine	Check connection.
	Detergent is too thick	Dilute detergent. For best results, use manufacturers detergent.
	Detergent filter valve is at lowest setting	Set detergent filter valve to a higher setting.
	Filter on detergent suction tube is clogged	Run warm water through filter to remove debris.
	Damaged or clogged detergent suction tube	Remove obstruction or replace detergent suction tube.
	A high pressure nozzle is attached.	Replace with black detergent nozzle.
	Discharge nozzle is obstructed	Blow out or remove debris with fine needle.
GARDEN HOSE CONNECTION LEAKS	Loose fittings	Tighten fittings.
	Missing/worn rubber washer	Insert new washer.
SPRAY WAND LEAKS	Spray wand not properly attached	Slide the spray wand into the gun. Turn the wand collar clockwise onto the spray gun threads until tight.
	Broken o-ring	Call local distributor and order an o-ring.
PUMP IS NOISY	Pump is sucking air	Check that hoses and fittings are air tight. Turn off machine and purge pump by squeezing trigger gun until a steady flow of water emerges through nozzle.

PREVENTATIVE MAINTENANCE

This pressure washer was produced with the best available materials and quality craftsmanship. However, you as the owner have certain responsibilities for the correct care of the equipment. Attention to regular preventative maintenance procedures will assist in preserving the performance of your equipment. Contact your dealer for maintenance. Regular preventative maintenance will add many hours to the life of your pressure washer. Perform maintenance more often under severe conditions. Check pump oil and engine oil level before first use of your new pressure washer.

MAINTENANCE SCHEDULE		
Engine Oil	Inspect	Daily
	Change	First month or 20 hours. Every 100 hours or every 6 months after first month
	Filter	Every 50 hours
Air Cleaner/Filter	Inspect	Every 50 hours
	Clean	Monthly
Engine Fuel Filter		500 hours or 6 months
Spark Plug Maintenance		300 hours or annually
Clean Fuel Tank(s)		Annually
Replace Fuel Lines		Annually
Pump Oil (Comet and G Series pumps only)	Inspect	Oil level daily
	Change	After first 50 hours, then every 500 hours or annually
Replace High Pressure Nozzle		Every 6 months
Replace Quick Connects/O-Rings		Annually/As needed
Clean Water Screen/Filter		Weekly
Replace HP Hose		Annually (if there are any signs of wear)

OIL CHANGE RECORD

Check pump oil and engine oil level before first use of your new pressure washer.

Date Oil Changed Month/Day/Year	Estimated Operating Hours Since Last Oil Change

Date Oil Changed Month/Day/Year	Estimated Operating Hours Since Last Oil Change

