

# PARTS BREAKDOWN FOR HD 2.3/15CEd (1.150-611.0)

Location	PN	DESCRIPTION	QTY	SERIAL #	
				FROM	TO
<b>HOUSING 1.0</b>					
1	5069-1210	Device cover	1		
1.150-610.0 / -611.0 /-616.0					
1	5069-2020	Device cover	1		
1.150-614.0 /					
2	6304-0990	Saucer-head screw M 6x 18-4.8-R2R	1		
3	6310-0530	Putting nut	1		
4	5050-2060	Frame front part	1		
1.150-614.0 /					
4	5050-2860	Frame front part	1		
1.150-610.0 / -611.0 /-616.0					
5	5032-5540	Guide	2		
6	5321-7210	Hand grip	1		
7	5050-2070	Frame rear panel	1		
8	6315-0860	Rivet	4		
9	5032-5560	Covering cap	1		
10	2885-0070	Spare part set Griff	1		
11	4063-7780	Proportioning valve chemistry	1		
12	7311-0610	Hexagon nut M6-LH -8-A2E ISO 4032	1		
13	5105-3990	Axle	1		
14	6435-7560	Wheel grey D200	2		
1.150-614.0 /					
14	6435-6620	Wheel D200	2		
1.150-610.0 / -611.0 /-616.0					
15	4515-1030	Set (of 2 pieces)	1		
1.150-610.0 / -611.0 /-616.0					
15	4515-2730	Spare parts set wheel cab	1		
1.150-614.0 /					
16	5044-2160	Holder	1		
17	7303-1080	Screw 5x20 -10.9-R2R (In6Rd)	10		
18	6388-2160	Hose DN 5	1		
19	7312-2600	Washer 6 -100HV-A3E ISO 7094	1		
20	5731-6090	Filter with weight	1		
21	5032-5550	Guide	2		
22	5057-0620	Support	2		
1.150-610.0 / -611.0 /-616.0					
22	5057-0770	Support	2		
1.150-614.0 /					
23	6343-1680	CHASSIS CLIP	2		
24	7303-0460	Screw M6x12 -St-R3R (In6Rd)	2		
25	5037-1700	Hook	1		
26	5064-2170	Cover air inlet	1		
27	5107-2480	Bar shearing shackle	2		

## **R J Bowers Distributors**

2003 Harrison Ave  
 Rockford IL 61104  
 E-mail: [service@rjbowers.com](mailto:service@rjbowers.com)  
 Web: [www.rjbowers.com](http://www.rjbowers.com)  
 (815) 399-8839 (800) 383-6584

# PARTS BREAKDOWN FOR HD 2.3/15CEd (1.150-611.0)

Location	PN	DESCRIPTION	QTY	SERIAL # FROM	TO
----------	----	-------------	-----	------------------	----

HOUSING 1.0 continued

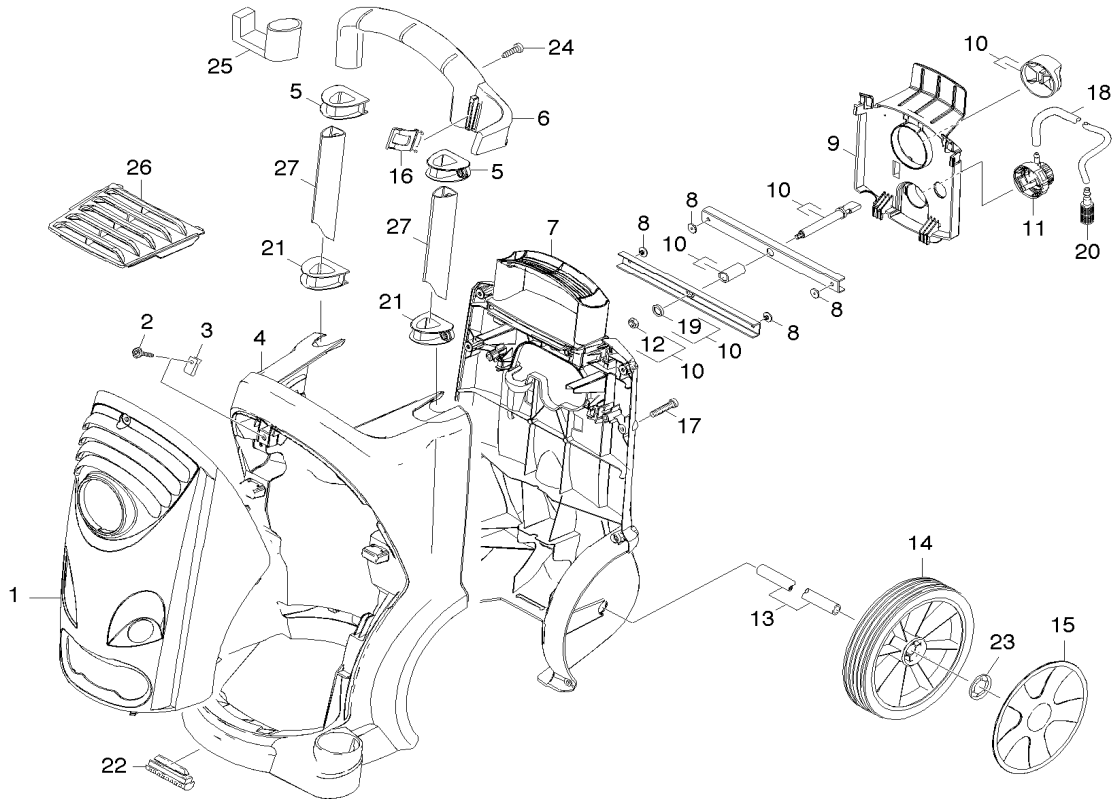

**R J Bowers Distributors**  
 2003 Harrison Ave  
 Rockford IL 61104  
 E-mail: [service@rjbowers.com](mailto:service@rjbowers.com)  
 Web: [www.rjbowers.com](http://www.rjbowers.com)  
 (815) 399-8839 (800) 383-6584

# PARTS BREAKDOWN FOR HD 2.3/15CEd (1.150-611.0)

Location	PN	DESCRIPTION	QTY	SERIAL #	
				FROM	TO
<b>PUMP SET - Cylinder Head 2.1</b>					
1	7306-1050	Screw M6x30 -8.8-R3R (In6Rd)	4		
2	6414-2520	Strainer	1		
3	5064-1500	Suction cover	1		
4	2884-9160	Valve (3 Stück)	2		
5	7303-1080	Screw 5x20 -10.9-R2R (In6Rd)	1		
6	5402-7270	Suction nipple	1		
7	6362-4810	O-Ring seal 14,0x2,0-NBR 80	1		
8	5064-2300	Suction cover	1		
9	5550-3240	Cylinder head	1		
10	2884-5010	Spare parts set control piston	1		
11	4132-0070	DRAIN PLUG	4		
12	5003-9830	Plate	1		
13	5443-3550	Nipple	1		
14	6362-1130	O-Ring seal 6,0 X 2,0	1		
15	7401-9080	Sphere 7 G300 -1.4301 DIN 5401	1		
16	6362-1750	O-Ring seal 5,28x 1,78	1		
17	5332-2580	Helical spring	1		
18	6362-3840	O-Ring seal 9,0 x 1,5	1		
19	6362-8510	O-Ring seal 4 x 2 NBR 90	1		
20	5584-0910	Valve pin check valve	1		
21	4769-0340	Nozzle insert only for replacement	1		
22	7306-1290	Screw M6x40 -8.8-R3R (In6Rd)	4		
23	6362-5330	O-Ring seal 14,0 X 1,5-NBR 70	3		
24	4591-0380	BYPASS VALVE	1		
25	5365-2840	Profile gasket	1		
27	5110-6300	SLEEVE	1		
28	7314-6290	Grooved pin 2x10 -A1 ISO 8742	1		
29	5583-1470	VALVE SCREW	1		
30	6362-4680	O-Ring seal complete 1ST.-R.	1		
31	4291-0140	Spindle complete	1		
32	5321-3070	Handhold	1		
33	4744-1900	Switch complete	1		
1.150-616.0					
33	4744-1930	Switch complete	1		
1.150-610.0 /-611.0 /-614.0 /					
34	5034-4940	Strap	1		
35	4401-0590	SCREW UNION PART	1		
36	5364-1290	Flat gasket	1		
38	6421-3200	Pressure gauge 0-15 MPa	1		
/1.150-611.0 / -614.0 /-616.0 /					
38	6421-2740	Pressure gauge	1		
/1.150-610.0					
39	4401-0700	SCREW UNION PART	1		
1.150-616.0					
40	6362-0780	O-Ring seal 13,3x2,4	1		
1.150-616.0					
41	5310-0650	Nut	1		
1.150-616.0					
42	5443-2290	Hose stem	1		
1.150-616.0					
43	5005-3140	Plate suction cover	1		
100	2883-9970	PUMP SET HD 5/12 C	1		

**R J Bowers Distributors**  
 2003 Harrison Ave  
 Rockford IL 61104  
 E-mail: service@rjbowers.com  
 Web: www.rjbowers.com  
 (815) 399-8839 (800) 383-6584

# PARTS BREAKDOWN FOR HD 2.3/15CEd (1.150-611.0)

Location	PN	DESCRIPTION	QTY	SERIAL #	
				FROM	TO
<b>PUMP SET - Cylinder Head 2.1 continued</b>					

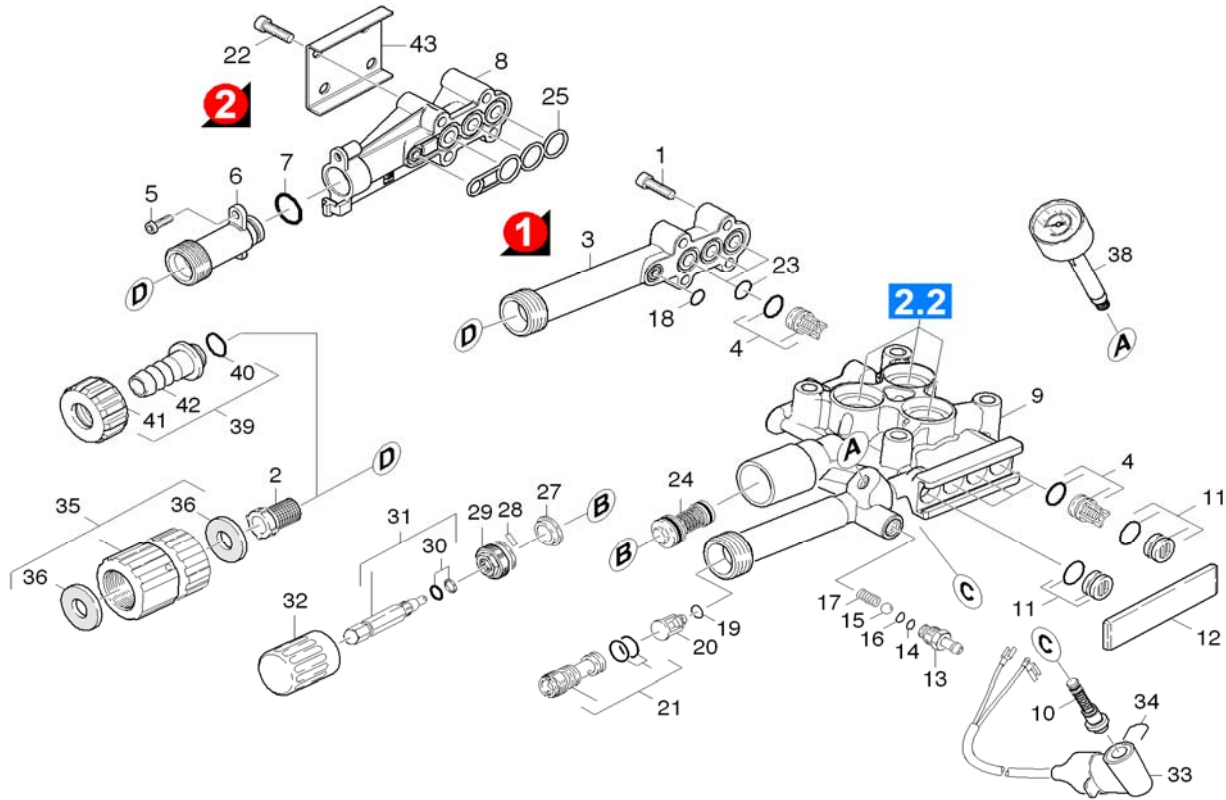

**R J Bowers Distributors**  
 2003 Harrison Ave  
 Rockford IL 61104  
 E-mail: [service@rjbowers.com](mailto:service@rjbowers.com)  
 Web: [www.rjbowers.com](http://www.rjbowers.com)  
 (815) 399-8839 (800) 383-6584

# PARTS BREAKDOWN FOR HD 2.3/15CEd (1.150-611.0)

Location	PN	DESCRIPTION	QTY	SERIAL #	
				FROM	TO
<b>PUMP SET - Thrust Guidance 2.2</b>					
1	4553-2310	Piston complete only for replacement	3		
/1.150-610.0					
1	4553-2650	Piston complete only for replacement	1		
/1.150-611.0 / -614.0 /-616.0 /					
2	5061-0180	Thrust guidance	1		
3	6365-3930	Oil sealing 12x20x4/6	3		
4	7303-0470	Screw M6x16 -St-R3R (In6Rd)	2		
5	6363-2520	O-Ring seal 75,87 x 2,62	1		
6	5112-7260	Bush	3		
1.150-610.0 / -611.0 /-616.0					
7	5116-0930	Washer	3		
1.150-610.0 / -611.0 /-616.0					
8	6365-4770	Grooved ring	6		
1.150-610.0 / -611.0 /-616.0					
9	6362-3760	O-Ring seal 24,0 X 1,5	3		
10	5115-7210	Washer	3		
11	6363-4020	O-Ring seal 11x3 NBR	3		
1.150-614.0 /					
12	5362-0120	Joint ring D 12	3		
1.150-614.0 /					
13	5112-8250	Bush	3		
1.150-614.0 /					
14	5116-3350	Washer	3		
1.150-614.0 /					
15	7306-1060	Cylinder head screw M8x70 -8.8-A2E ISO4	4		

**R J Bowers Distributors**  
 2003 Harrison Ave  
 Rockford IL 61104  
 E-mail: [service@rjbowers.com](mailto:service@rjbowers.com)  
 Web: [www.rjbowers.com](http://www.rjbowers.com)  
 (815) 399-8839 (800) 383-6584

# PARTS BREAKDOWN FOR HD 2.3/15CEd (1.150-611.0)

Location	PN	DESCRIPTION	QTY	SERIAL #	
				FROM	TO
<b>PUMP SET - Thrust Guidance 2.2 continued</b>					

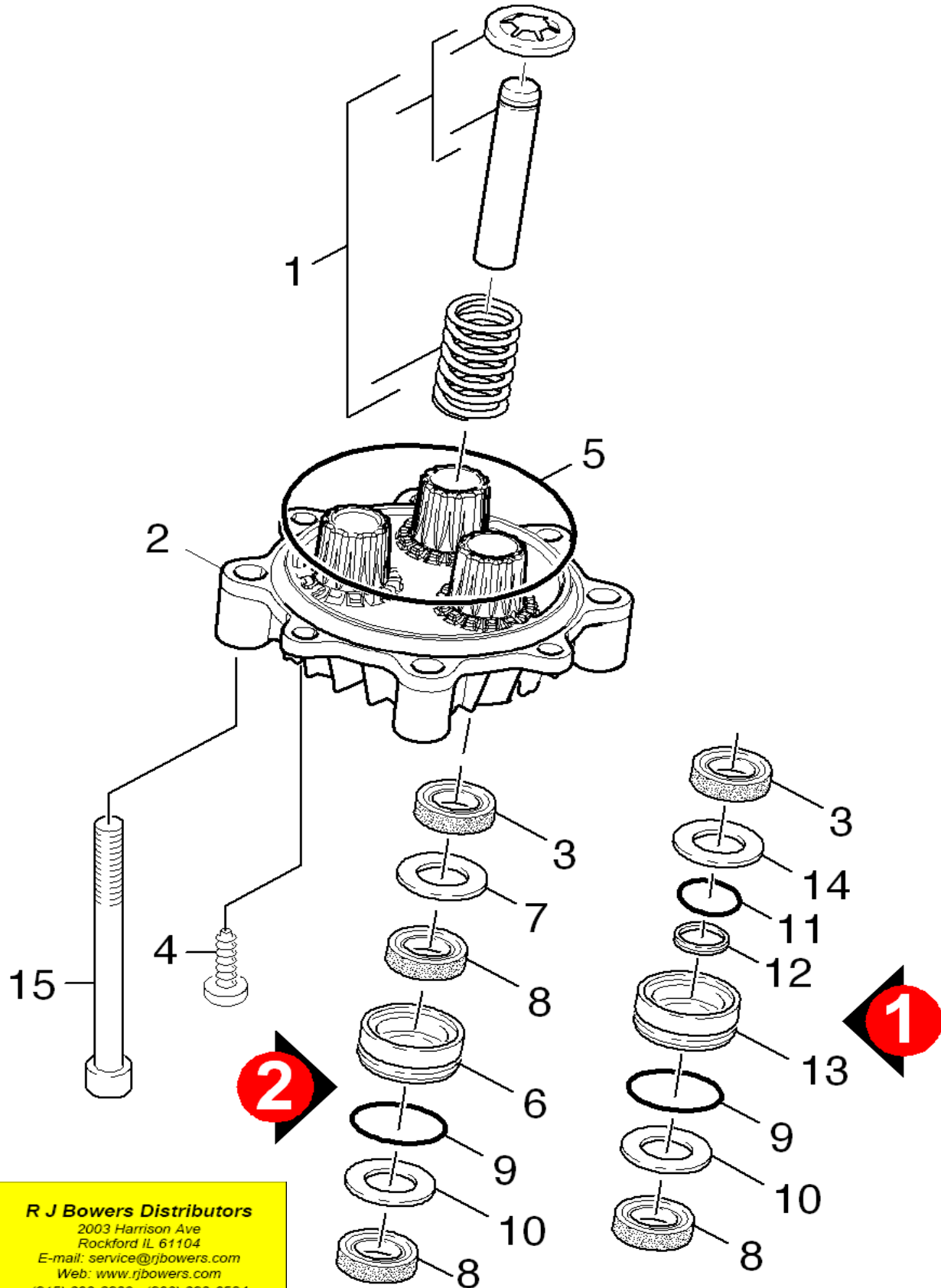

**R J Bowers Distributors**  
 2003 Harrison Ave  
 Rockford IL 61104  
 E-mail: [service@rjbowers.com](mailto:service@rjbowers.com)  
 Web: [www.rjbowers.com](http://www.rjbowers.com)  
 (815) 399-8839 (800) 383-6584

# PARTS BREAKDOWN FOR HD 2.3/15CEd (1.150-611.0)

Location	PN	DESCRIPTION	QTY	SERIAL #	
				FROM	TO
<b>MOTOR 3.0</b>					
0	4623-8530	Motor complete only for replacement	1		
/1.150-610.0					
0	4623-8580	Motor complete only for replacement	1		
/1.150-611.0 / -614.0 /-616.0 /					
1	5070-6390	OIL TANK	1		
2	5063-1950	Cover	1		
3	6303-1530	Screw M5x15-ST-A2R (IN6RD)	1		
4	5064-1970	Bearing cover B	1		
5	5600-0600	Blower wheel	1		
6	5692-0810	Air circulation	1		
7	6303-3200	Screw M 5x 20-St-R2R	4		
9	7367-0010	Radial shaft seal ring A24x37x7 -NBR DI	1		
10	6401-4100	Angular contact ball bearing	1		
11	5802-2880	Mounting part	2		
12	4120-2160	Swash plate completely	1		
/1.150-610.0					
12	4120-2190	Swash plate complete	1		
/1.150-611.0 / -614.0 /-616.0 /					
13	7303-1080	Screw 5x20 -10.9-R2R (In6Rd)	2		
15	7306-0420	Cylinder head screw M8x25 -8.8-A2E ISO4	1		
17	6288-2190	Engine oil 1 L	1		
/1.150-611.0 / -614.0 /-616.0 /					
17	6288-0500	Engine oil 1L	1		
/1.150-610.0					
18	5767-0050	Rubber buffer	4		
19	7401-1280	Ball bearing 6202-2RS -Wälzl.St DIN 625	1		
22	7312-2770	Washer 8-200HV-A2E ISO7093-1	1		
23	7313-0040	Spring washer B 8-FSt-A3E DIN 127	1		

**R J Bowers Distributors**

2003 Harrison Ave  
 Rockford IL 61104  
 E-mail: [service@rjbowers.com](mailto:service@rjbowers.com)  
 Web: [www.rjbowers.com](http://www.rjbowers.com)  
 (815) 399-8839 (800) 383-6584

# PARTS BREAKDOWN FOR HD 2.3/15CEd (1.150-611.0)

Location	PN	DESCRIPTION	QTY	SERIAL #	
				FROM	TO
<b>MOTOR 3.0 continued</b>					

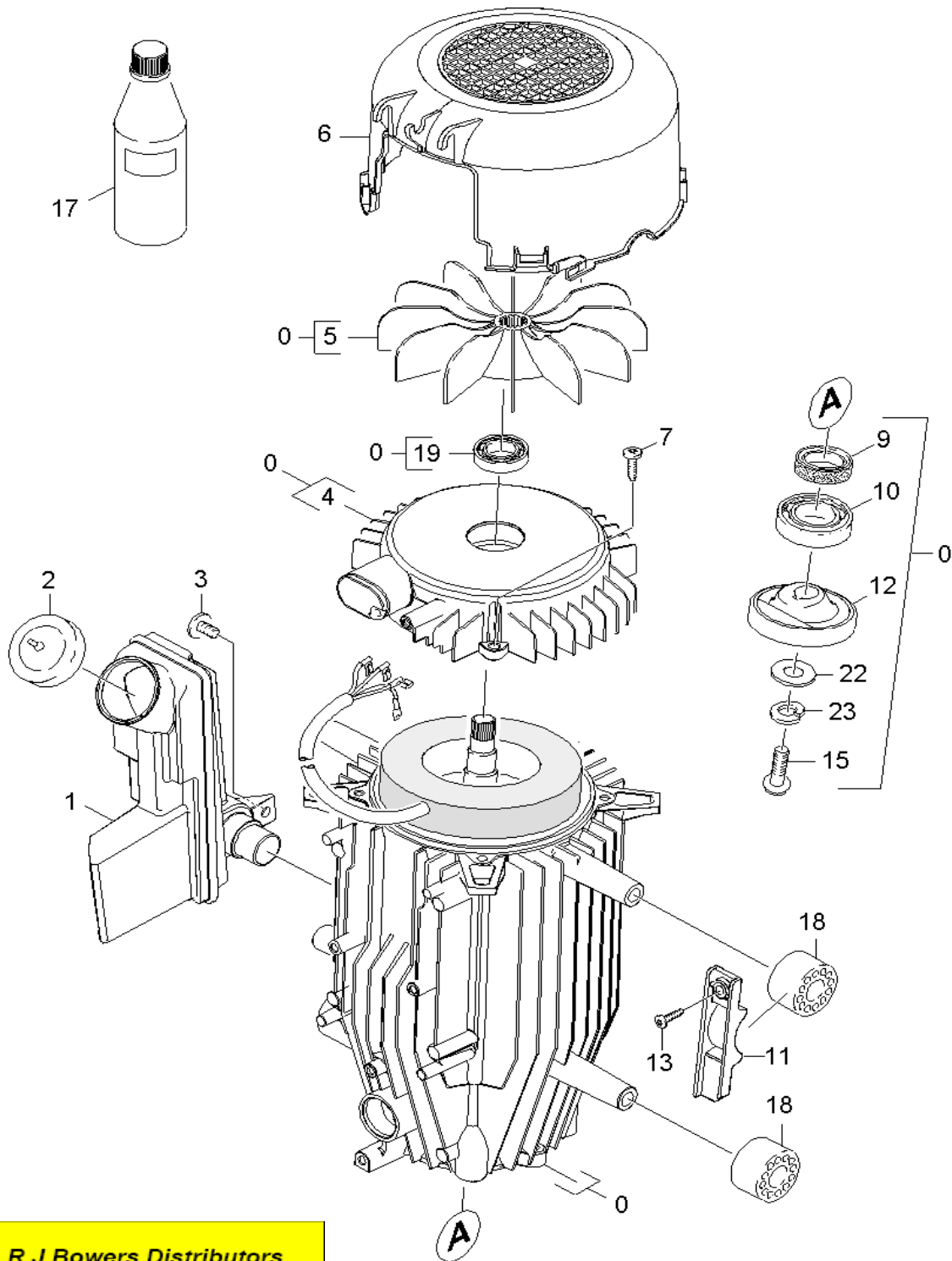

**R J Bowers Distributors**  
 2003 Harrison Ave  
 Rockford IL 61104  
 E-mail: [service@rjbowers.com](mailto:service@rjbowers.com)  
 Web: [www.rjbowers.com](http://www.rjbowers.com)  
 (815) 399-8839 (800) 383-6584

# PARTS BREAKDOWN FOR HD 2.3/15CEd (1.150-611.0)

Location	PN	DESCRIPTION	QTY	SERIAL #	
				FROM	TO
<b>ELECTRICAL BOX 5.0</b>					
1	5388-5120	Label	1		
2	4063-8100	Cover completely	1		
3	5365-1810	SEAL	1		
4	5064-2420	Housing with bore	1		
5	6661-2740	Capacitor 100 µF	1		
/1.150-611.0 / -614.0 /-616.0 /					
5	6661-2540	Capacitor 80 µF	1		
1.150-610.0					
6	6649-4670	Cable without plug	1		
1.150-616.0					
6	6649-3610	Cable with plug GFCI	1		
/1.150-611.0 / -614.0 /					
6	6649-3590	Cable with plug GFCI	1		
1.150-610.0					
7	7303-0310	Screw M4x10 -St-P2R (In6Rd)	1		
8	5263-0580	CLAMP ELEMENT	1		
1.150-610.0 /-616.0					
8	5263-0510	CLAMP ELEMENT	1		
1.150-611.0 /-614.0 /					
9	6303-2000	Screw 5x25-IN6RD	1		
10	6303-1530	Screw M5x15-ST-A2R (IN6RD)	3		
11	6632-4220	Contactactor 7,5 kW / 115 V	1		
1.150-611.0 / -614.0 /-616.0					
11	6632-4210	Contactactor 7,5 kW / 220 V	1		
1.150-610.0					
12	5048-2510	Plate	1		
13	6630-0490	Cap	1		
14	6631-1960	Motor protecting switch	1		
16	5043-0500	Holder for capacitor	1		
17	7303-0370	Screw M5x10 -St-P2R (In6Rd)	1		
18	7312-0540	Washer 12-A2 ISO 7090	1		
19	7311-0710	Hexagon nut M12-A2-70 ISO 4032	1		

**R J Bowers Distributors**  
 2003 Harrison Ave  
 Rockford IL 61104  
 E-mail: [service@rjbowers.com](mailto:service@rjbowers.com)  
 Web: [www.rjbowers.com](http://www.rjbowers.com)  
 (815) 399-8839 (800) 383-6584

# PARTS BREAKDOWN FOR HD 2.3/15CEd (1.150-611.0)

Location	PN	DESCRIPTION	QTY	SERIAL #	
				FROM	TO
<b>ELECTRICAL BOX 5.0 continued</b>					

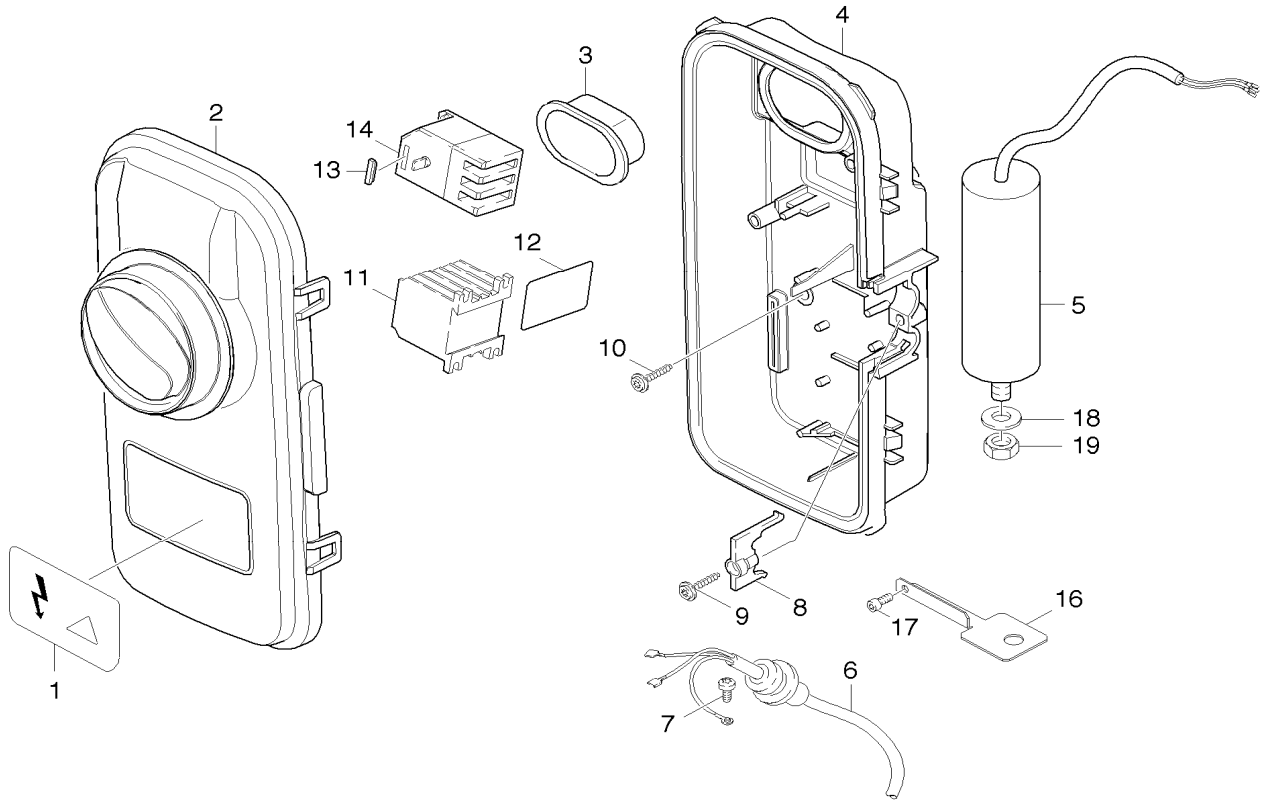

**R J Bowers Distributors**  
 2003 Harrison Ave  
 Rockford IL 61104  
 E-mail: [service@rjbowers.com](mailto:service@rjbowers.com)  
 Web: [www.rjbowers.com](http://www.rjbowers.com)  
 (815) 399-8839 (800) 383-6584