

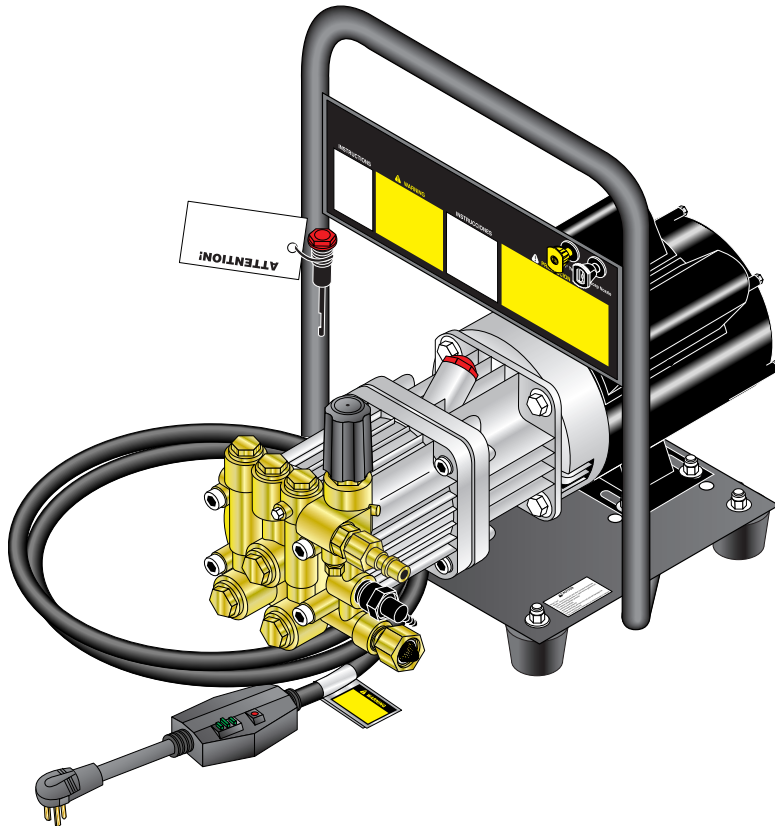

KÄRCHER

OPERATOR'S MANUAL



<u>MODEL</u>	<u>ORDER #</u>	<u>MODEL</u>
HD 2.0/10 Ed	1.575-400.0	HE-201006D
HD 1.8/14 Ed	1.575-401.0	HE-201406D

To locate your local Kärcher Commercial Pressure Washer Dealer nearest you,
visit www.karchercommercial.us

9.800-088.0

EXPLODED VIEW

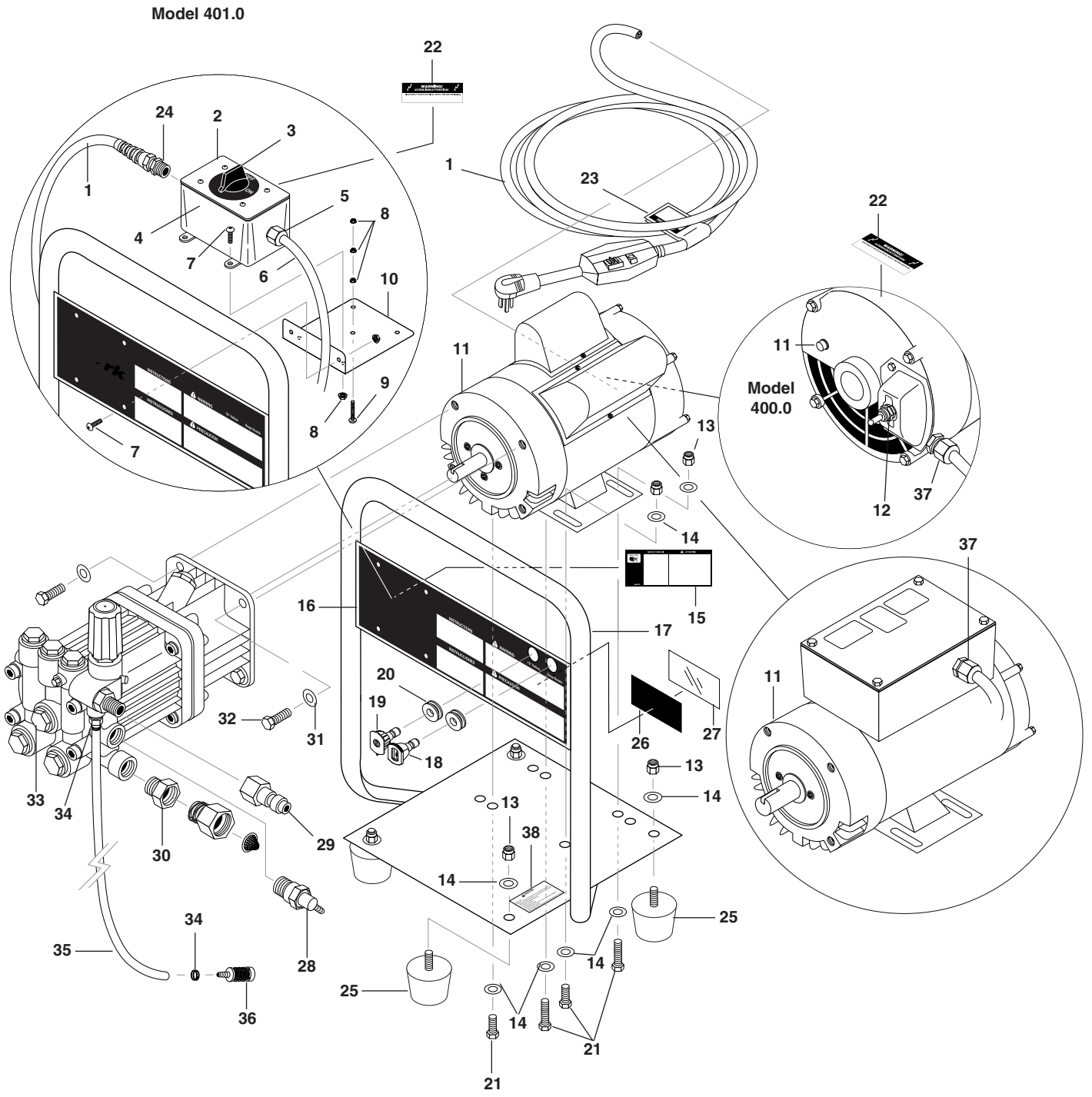

EXPLODED VIEW PARTS LIST

ITEM	PART NO.	DESCRIPTION	QTY
1	9.802-432.0	GFCI, 120V 15 Amp w/36' 12-3 Cord(400.0)	1
	9.802-431.0	GFCI, 120V 20 Amp w/36' 12-3 Cord(401.0)	1
2	9.802-478.0	Lid, Plastic Carlon (401.0)	1
3	9.802-450.0	Switch, 2 Position 120V-600V (401.0)	1
4	9.802-477.0	Box, Plastic Carlon (401.0)	1
	9.800-040.0	▲ Label, Ground	1
5	9.802-518.0	Strain Relief, Strt, LQ Tite, Large (401.0)	1
	9.802-523.0	▲ Locknut, 3/4" Conduit	1
6	9.802-427.0	Cord, Service, SOWA, 12/3 (401.0)	2 ft.
7	9.802-759.0	Screw, 10/32" x 1/2" BHSOC (401.0)	6
8	9.802-695.0	Nut, 10/32" Keps (401.0)	9
9	9.802-699.0	Screw, 10-32" x 3/4" RH, SL, Black (401.0)	1
10	9.803-128.0	Bracket, Switch Box (401.0)	1
11	9.802-338.0	Motor, 1.5 HP, 1 PH, 3450 RPM (400.0)	1
	9.802-339.0	Motor, 2 HP, 1 PH, 3450 RPM (401.0)	1
12	9.802-454.0	Switch, Toggle, Assy (400.0)	1
13	9.802-776.0	Nut, 5/16" ESNA, NC	8
14	9.802-804.0	Washer, 5/16" Flat SAE	12
15	9.800-037.0	Label, French Warning	1
16	9.800-059.0	Label, Instructions	1
17	9.802-873.0	Handle Assy, Black	1
18	9.802-311.0	Nozzle, Compl. QCEM-6540 w/Black Nylon (Soap Nozzle)	1
19	9.804-624.0	Nozzle, SAQCMEG 150375 Yellow (400.0)	1
	9.802-288.0	Nozzle, SAQCMEG 1503 Yellow (401.0)	1
20	9.802-064.0	Grommet, Rubber, Nozzle Holder	2
21	9.802-709.0	Bolt, 5/16" x 3/4" NC	4
22	9.800-016.0	Label, Disconnect Power	1
23	9.800-015.0	Label, Warning, Service Cord	1
24	9.802-516.0	Strain Relief, 90° (401.0)	1
	9.802-524.0	▲ Locknut, 1/2" Conduit (401.0)	1
25	9.802-063.0	Mount, Vibration, 5/16"-18 x 9/16" Stud, 30 Duro	4
26	9.800-013.0	Label, Intended For Indoor Use	1
27	9.800-034.0	Label, Clear Lexan, 2-1/4" x 4-1/2"	1
28	9.802-181.0	Pump Protector, 3/8" PTP	1
29	9.802-170.0	Nipple, 3/8" x 3/8" NPT ST Female	1
30	9.802-148.0	Adapter, 1/2" x 1/2" Pipe	1
31	9.802-807.0	Washer, 3/8" Flat SAE	4
32	9.802-720.0	Bolt, 3/8" x 1", NC	4
33	9.802-357.0	Pump, Comet AXD2020E	1
34	9.802-210.0	Clamp, Hose UNI .46 - .54	2
35	9.802-251.0	Hose, 1/4" x 1/2" Clear Vinyl	6 ft.
36	9.802-160.0	Strainer, 1/4" Barb	1

EXPLODED VIEW PARTS LIST

ITEM	PART NO.	DESCRIPTION	QTY
37	9.802-514.0	Strain Relief, Straight, LQ Tite (400.0)	1
	9.802-525.0	▲ Locknut, 1/2" (400.0)	1
	9.802-518.0	Strain Relief, 3/4" Strt. LQ Tite (401.0)	1
	9.802-526.0	▲ Locknut, 3/4" (401.0)	1
38	9.800-049.0	Label, Manufacturer's Cleaning Solution	1
39	9.800-095.0	Tag, Pump Plug/Vented Cap	1

▲ Not Shown

HOSE & SPRAY GUN ASSEMBLY

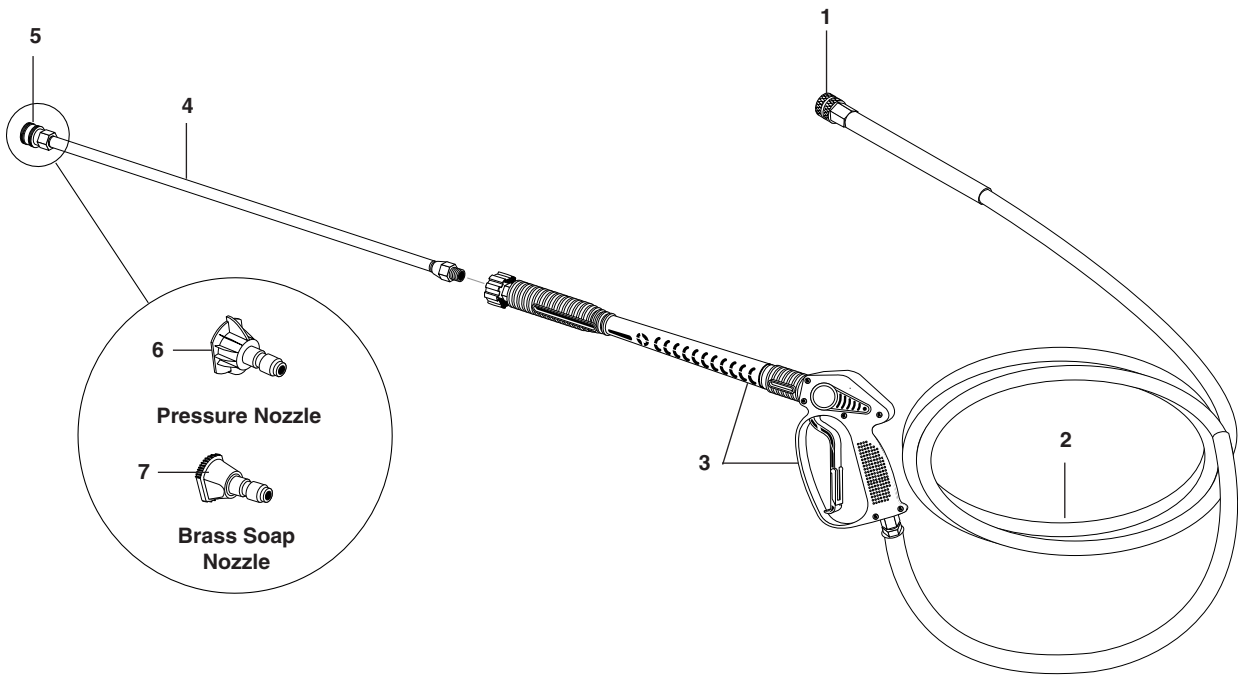

HOSE & SPRAY GUN ASSEMBLY PARTS LIST

ITEM	PART NO.	DESCRIPTION	QTY
1	9.802-166.0	Coupler, 3/8" Female	1
	9.802-100.0	▲ Quick Coupler O-Ring	1
2	8.739-125.0	Hose, 3/8" x 50', Tuff-Flex, 1 Wire	1
3	9.802-223.0	Spray Gun, Shut-Off	1
4	9.802-220.0	Wand, Straight	1
5	9.802-164.0	Coupler, 1/4" Female	1
	9.802-096.0	Quick Coupler O-Ring	1
6	9.802-288.0	Nozzle, 3.0 15° Yellow (401.0)	1
	9.804-624.0	Nozzle, 3.75 15° Yellow (400.0)	1
7	9.802-311.0	Nozzle, Brass Soap	1

▲ Not Shown

AXD PUMP EXPLODED VIEW

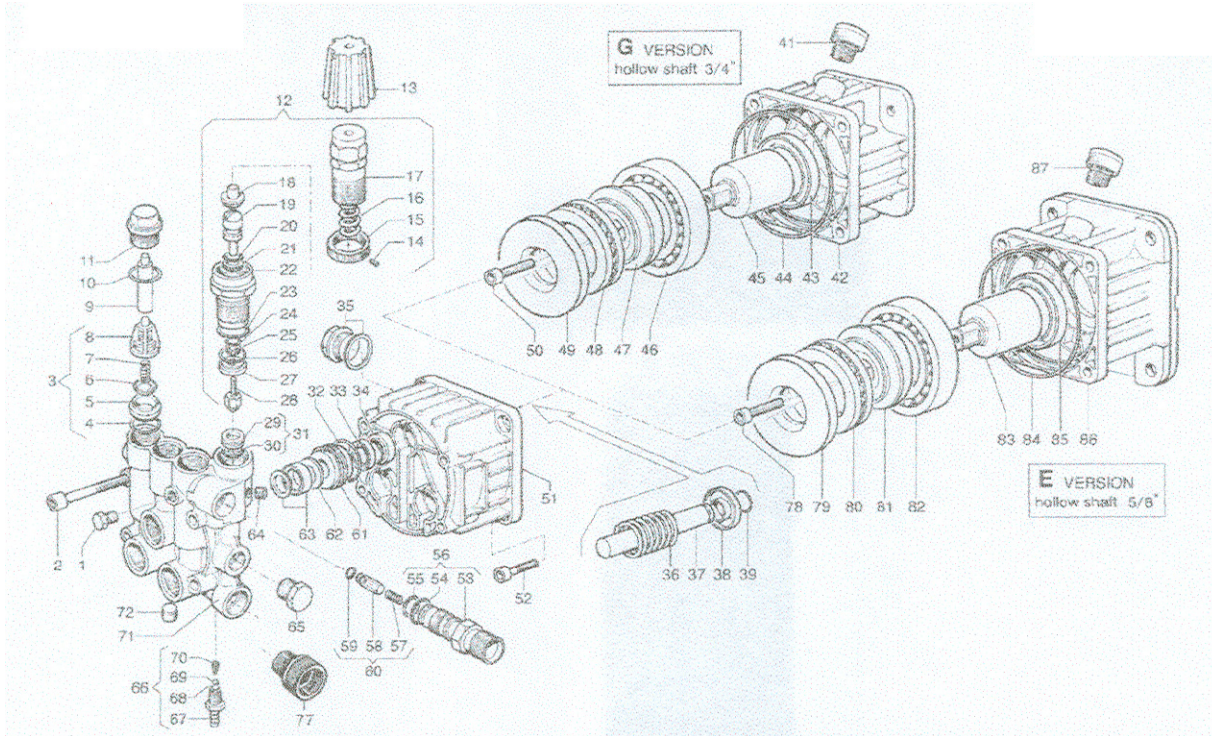

AXD PUMP EXPLODED VIEW PARTS LIST

ITEM	PART #	DESCRIPTION	KIT	QTY	ITEM	PART #	DESCRIPTION	KIT	QTY
1	89-3202.0018.00	Cap, 1/8"		1	23	89-1210-0407.00	O-Ring	E-F	1
2	89-3609.0156.00	Screw M8x55		4	24	89-1210.0405.00	O-Ring	E-F	1
3	89-1220.0045.00	Valve Kit		6	25	89-0009.0205.00	Ring	E-F	1
4	89-1210.0049.00	O-Ring, 1.78 x 12.42 A-D		6	26	89-1210.0404.00	O-Ring	E-F	1
5	89-3009.0129.00	Valve Seat	A	6	27	89-0009.0204.00	Ring	E-F	1
6	89-3604.0028.00	SUC/DEL Valve	A	6	28	89-3002-0508.00	Housing with Ball	E-F	1
7	89-1802.0192.00	Spring	A	6	29	89-3009.0122.00	Seat	E-F	1
8	89-1206.0033.00	Valve Cage	A	6	30	89-1210.0403.00	O-Ring	E-F	1
9	89-0601.0273.00	Spacer		2	31	89-3009.0013.00	Valve Seat		1
10	89-1210.0151.00	O-Ring, 1.78 x 17.77 A-D		6	32	89-1210-0356.00	O-Ring, 1.78 x 25.12 B-D		3
11	89-3202.0236.00	Plug		6	33	89-1241.0050.00	Piston Seal Ø14	B	3
12	89-1215-0271.00	Reg Val Kit for AX 180 Bar		1	34	89-0019.0103.00	Sealing Ring	D	3
13	89-1817.0053.00	Knob		1	35	89-3201.0018.00	Oil Level Plug		1
14	89-3622.0030.00	Stop, Adjustable Nut, M4x4	E	1	36	89-1802-0153.00	Spring		3
15	89-1227.0022.00	Nut	E	1	37	89-2409.0089.00	Piston	C	3
16	89-1802-0182.00	Spring,	E	1	38	89-0009.0221.00	Ring	C	3
17	89-0204.0046.00	Adjustable Knob	E	1	39	89-0009.0220.00	Ring Ø14	C	3
18	89-0009.0207.00	Seat	E	1	51	89-0403.0135.00	Pump Crankcase		1
19	89-2409.0077.00	Piston Rod	E-F	1	52	89-3609.0005.00	Screw M8x20		4
20	89-1210.0406.00	O-Ring	E-F	1	53	89-3410.0295.00	Injector Body M22 x 1.5	E	1
21	89-0009.0206.00	Ring	E-F	1		89-3410.0298.00	Injector Body, 3/8 NPT	E	1
22	89-0204-0045.00	Housing	E	1	54	89-1210.0049.00	O-Ring 1.78 x 12.42 D-E-F		1
					55	89-1210.0040.00	O-Ring, 1.78 x 15.6	E-F	1

AXD PUMP EXPLODED VIEW PARTS LIST

ITEM	PART NO.	DESCRIPTION	KIT	QTY
56	89-3410.0302.00	Injector Body Kit M22x 1.5		1
	89-3410.0303.00	Injector Body Kit 3/8 NPT		1
57	89-1802.0197.00	Spring	E	1
58	89-2409.0086.00	Check Valve	E	1
59	89-1210.0397.00	O-Ring	E-F	1
60	89-2409.0091.00	Check Valve Kit		1
61	89-0009.0219.00	Ring		3
62	89-0009.0230.00	Ring	B	3
63	89-1241.0055.00	Piston Seal 150 Bar (2520G, 3020G, 3522G)	B	3
	89-1241.0056.00	Piston Seal 180 Bar (3025G)	B	3
64	89-3200.0017.00	Plug 1/8 x 8		1
65	89-3200.0007.00	Plug 3/8 Gas OT58		1
66	89-2803.0435.00	Injector Kit		1
67	89-2003.0425.00	Hose Barb Fitting		1
68	89-2812.0067.00	O-Ring		1
69	89-3003.0026.00	Ball		1
70	89-1802.0180.00	Spring		1
71	89-3218.0299.00	Pump Valve Chamber		1
72	89-3200.0017.00	Plug 1/8 x 8		1
77	89-2800.0081.00	Garden Hose Tail		1

Kit A	89-5025.0014.00	Complete Valve Kit
Kit B	89-5019.0077.00	Piston Seal Kit, 150 Bar
	89-5019.0078.00	Piston Seal Kit, 180 Bar
Kit C	89-2409.0092.00	Piston Kit
Kit D	89-5019.0079.00	Seal Kit
Kit E	89-5026.0142.00	Overhaul Kit, M22 x 1.5
	89-5026.0143.00	Overhaul Kit, 3/8" NPT
Kit F	89-5026.0144.00	Maintenance Kit

**LIMITED NEW PRODUCT
WARRANTY—COMMERCIAL
PRESSURE WASHERS**



Phone: 360-833-1600
Fax: 800-248-8409
www.karchercommercial.us

WHAT THIS WARRANTY COVERS

All Kärcher commercial pressure washers are warranted by Kärcher to the original purchaser to be free from defects in materials and workmanship under normal use, for the periods specified below. This Limited Warranty, subject to the exclusions shown below, is calculated from the date of the original purchase, and applies to the original components only. Any parts replaced under this warranty will assume the remainder of the pressure washer's warranty period.

FIVE YEAR PARTS AND ONE YEAR LABOR WARRANTY

Components manufactured by Kärcher, such as frames, handles, float tanks, fuel tanks, belt guards, and heating coils. Internal components on the oil-end of Kärcher axial pumps have a 5 year warranty. Period of warranty on axial pumps shall be one year. Kärcher crankshaft pumps have a 7 year warranty on non-wear parts. Heating coils are pro-rated at 25% after 2 years. Stainless steel coils have a 10 year warranty.

ONE YEAR PARTS AND ONE YEAR LABOR WARRANTY

All other components, excluding normal wear items as described below, will be warranted for one year on parts and labor. Parts and labor warranty on these parts will be for one year regardless of the duration of the original component manufacturer's part warranty.

WARRANTY PROVIDED BY OTHER MANUFACTURERS

Motors, generators, and engines, which are warranted by their respective manufacturers, are serviced through these manufacturers' local authorized service centers. Kärcher is not authorized and has no responsibility to provide warranty service for such components. Motors manufactured outside of the United States will be warranted by Kärcher.

WHAT THIS WARRANTY DOES NOT COVER

This warranty does not cover the following items:

1. Normal wear items, such as nozzles, spray guns, discharge hoses, wands, quick couplers, seals, filters, gaskets, O-rings, packings, pistons, pump valve assemblies, strainers, belts, brushes, rupture disks, fuses, pump protectors.
2. Any components or other devices incorporated into a Kärcher product that are not manufactured by Kärcher, including, but not limited to gasoline engines, pumps, etc.
3. Defects caused by improper or negligent operation or installation, accident, abuse, misuse, neglect, unauthorized modifications, repair or maintenance of the product by persons other than authorized representatives of Kärcher, including, but not limited to, the failure of the Customer to comply with recommended product maintenance schedules.
4. Kärcher products that have been returned by the original Customer and are ultimately re-sold by an Authorized Servicing Dealer or other sales or service outlet to another purchaser.
5. Kärcher products that are sold by any distributor or retailer that is not an official authorized dealer or retailer of Kärcher products.
6. Defects caused by acts of nature and disaster including, but not limited to, floods, fires, wind, freezing, earthquakes, tornadoes, hurricanes and lightning strikes.
7. Defects caused by water sediments, rust corrosion, thermal expansion, scale deposits or a contaminated water supply (such as water in the unit with chloride content higher than that of 80 mg/liter or use of chemicals not approved or recommended by Kärcher).
8. Defects caused by improper voltage, voltage spikes or power transients in the electrical supply.
9. Devices or accessories not distributed or approved by Kärcher.
10. Any cost of labor arising from the removal and reinstallation of the alleged defective part by Customer.
11. Transportation of the product to an Authorized Servicing Dealer, field labor, replacement rental and any freight charges.

Any components, accessories or other devices provided with the product but not manufactured by Kärcher (such as engines, pumps, etc.) are subject to warranties and service through their respective manufacturers authorized service centers and according to the applicable terms and conditions of such manufacturers warranties. Such components or other devices not manufactured by Kärcher should be referred by the Customer to an authorized service center or their respective manufacturers for repair or replacement.

THE FOREGOING WARRANTY IS IN LIEU OF ALL OTHER WARRANTIES OF ANY KIND, WHETHER ARISING BY LAW, CUSTOM OR CONDUCT. KÄRCHER MAKES NO ADDITIONAL WARRANTIES, EITHER EXPRESSED OR IMPLIED, INCLUDING, WITHOUT LIMITATION, ANY EXPRESSED OR IMPLIED WARRANTIES OF MERCHANTABILITY OR FITNESS OF EQUIPMENT FOR A PARTICULAR PURPOSE AND ANY SUCH WARRANTIES ARE EXPRESSLY DISCLAIMED. KÄRCHER FURTHER DISCLAIMS ANY WARRANTY THAT THE PRODUCT PURCHASED BY CUSTOMER WILL MEET ANY PARTICULAR REQUIREMENT OF CUSTOMER EVEN IF KÄRCHER HAS BEEN ADVISED OF SUCH REQUIREMENT.

THE RIGHTS AND REMEDIES PROVIDED UNDER THIS WARRANTY ARE EXCLUSIVE AND IN LIEU OF ANY OTHER RIGHTS OR REMEDIES OF CUSTOMER. KÄRCHER SHALL NOT UNDER ANY CIRCUMSTANCES BE LIABLE TO ANY PERSON OR ENTITY INCLUDING, BUT NOT LIMITED TO, THE CUSTOMER OR ANY END USER OF THE PRODUCT FOR ANY SPECIAL, INDIRECT, INCIDENTAL OR CONSEQUENTIAL DAMAGES OR ECONOMIC LOSS, LOSS OF PROFITS OR LOSS OF USE OF THE PRODUCT, ARISING IN CONNECTION WITH THE SALE, DELIVERY, INSTALLATION, TRAINING OR USE OF PRODUCT. KÄRCHER'S LIABILITY, WHETHER IN CONTRACT OR IN TORT, ARISING OUT OF ANY WARRANTIES OR REPRESENTATIONS, INSTRUCTIONS OR DEFECTS FROM ANY CAUSE, SHALL BE LIMITED EXCLUSIVELY TO THE COST OF REPAIR OR REPLACEMENT PARTS UNDER AFORESAID CONDITIONS.

The purpose of the foregoing limitations on liability and Customer remedies is to protect Kärcher from unknown or undeterminable risks. Some states do not allow the exclusion or limitation of incidental or consequential damages, so the above limitation or exclusion may not apply to the Customer.

Kärcher sales and service representatives are not authorized to waive or alter the terms of this warranty, or to increase the obligations of Kärcher under the warranty.

Kärcher reserves the right to make design changes in any of its products without prior notification to the Customer.