

Spare parts list
(5.955-706.0) Spare parts list HD 1090 WS *

Table of contents

Spare parts list HD 1090 WS * (5.955-706.0)	6
10 Individual parts	7
11 Individual parts	8
12 Individual parts	11
20 Pump set	14
20 Cylinder head	15
21 Valves	17
22 Piston	19
23 Chemistry	21
30 Motor	23
30 Transmission	24
31 Ventilation	26
40 Accessories	28
41 Hand trigger gun	29
42 Hand trigger gun	32
13 Grooved ring only for replacement (4.363-695.0)	34
43 Jet pipe	35
44 Jet pipe	37
45 Nozzle	39
50 Electric control box	41

Spare parts list HD 1090 WS * (5.955-706.0)

Pos	Name	Qty.	Unit	from ser.nr.	up to ser.nr.
10	Individual parts	1.000	ST	0000000000	0000000000
20	Pump set	1.000	ST	0000000000	0000000000
30	Motor	1.000	ST	0000000000	0000000000
40	Accessories	1.000	ST	0000000000	0000000000
50	Electric control box	1.000	ST	0000000000	0000000000

10 Individual parts

Pos	Name	Qty.	Unit	from ser.nr.	up to ser.nr.	var. information
11	Individual parts	1.000	ST	0000000000	0000000000	VERSION 1
12	Individual parts	1.000	ST	0000000000	0000000000	VERSION 2

11 Individual parts

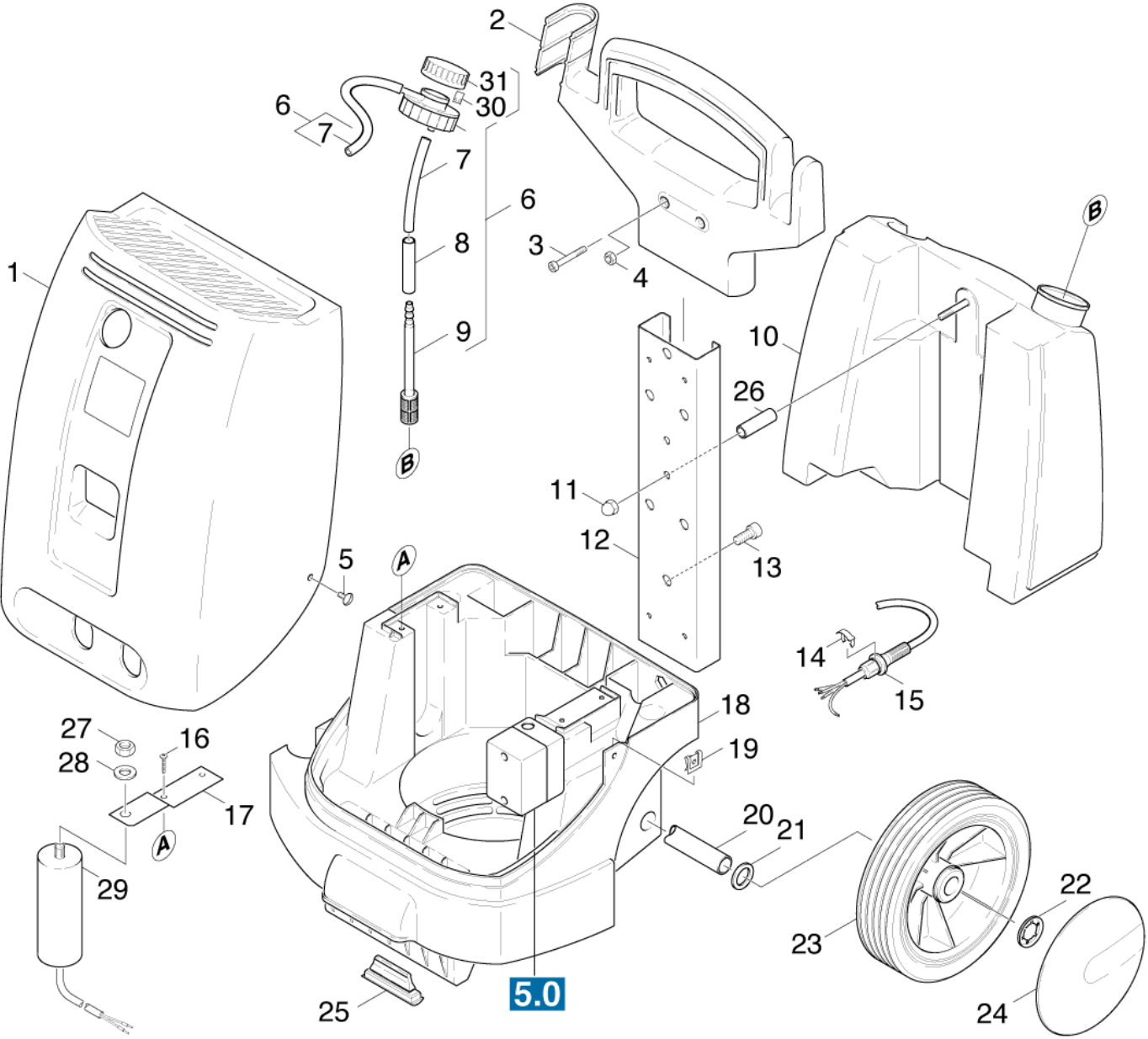

11 Individual parts

ET/VT (spare/wear parts)	Pos	Material #	Name	Qty.	Unit	from ser.nr.	up to ser.nr.	Footnote text
	1	5.067-031.0	Device cover for replacement	1.000	ST	0000000000	0000000000	
	2	5.321-423.0	Handhold	1.000	ST	0000000000	0000000000	
X	3	7.306-133.0	Screw M6x50 -8.8-R3R (In6Rd)	2.000	ST	0000000000	0000000000	
	4	7.311-003.0	Hexagon nut M6 -8-A2E ISO 4032	2.000	ST	0000000000	0000000000	
X-X	5	6.304-099.0	Saucer-head screw M 6x 18-4.8-R2R	2.000	ST	0000000000	0000000000	
	6	4.580-238.0	Proportioning valve chemistry	1.000	ST	0000000000	0000000000	
X-X	7	6.388-194.0	Hose DN 7	1.000	M	0000000000	0000000000	TO ORDER AS CUT GOODS
	8	5.025-747.0	Tube	1.000	ST	0000000000	0000000000	
X	9	6.414-136.0	Filter	1.000	ST	0000000000	0000000000	
	10	5.071-069.0	Tank	1.000	ST	0000000000	0000000000	
X-X	11	6.310-062.0	Cap nut M 8	1.000	ST	0000000000	0000000000	
	12	5.023-117.0	U-Section	1.000	ST	0000000000	0000000000	
	13	7.309-015.0	Screw assembly M8x16-8.8-A2E-S4-N ISO106	3.000	ST	0000000000	0000000000	
	14	6.343-170.0	Retaining clip	1.000	ST	0000000000	0000000000	
	15		Stockpiling discontinued	1.000	ST	0000000000	0000000000	
	15		Stockpiling discontinued	1.000	ST	0000000000	0000000000	
Position text: / 1.951-801.0								
	16	6.303-174.0	Screw 6,0X20-ST-A2R	2.000	ST	0000000000	0000000000	
	17	5.004-695.0	Strap	1.000	ST	0000000000	0000000000	
	18	5.605-209.0	Housing	1.000	ST	0000000000	0000000000	
X	19	6.310-053.0	Putting nut	2.000	ST	0000000000	0000000000	
	20	5.028-561.0	Tube	1.000	ST	0000000000	0000000000	
X	21	7.312-060.0	Washer 24-100HV-A3E ISO 7091	2.000	ST	0000000000	0000000000	
X-X	22	6.343-162.0	Lock washer -25	2.000	ST	0000000000	0000000000	
	23	6.435-236.0	Wheel D.250	2.000	ST	0000000000	0000000000	

11 Individual parts

ET/VT (spare/wear parts)	Pos	Material #	Name	Qty.	Unit	from ser.nr.	up to ser.nr.	Footnote text
	24	6.435-237.0	Wheel cap	2.000	ST	0000000000	0000000000	
	25	5.057-054.0	Support	2.000	ST	0000000000	0000000000	
	26	5.028-703.0	Tube	1.000	ST	0000000000	0000000000	
	27	7.311-008.0	Hexagon nut M12-8-A3E ISO 4032	1.000	ST	0000000000	0000000000	
	28	7.312-008.0	Washer 12-200HV-A3E ISO 7090	1.000	ST	0000000000	0000000000	
	29	6.661-199.0	Capacitor 100MUEF	1.000	ST	0000000000	0000000000	
X-X	30	5.337-021.0	Plate spring	1.000	ST	0000000000	0000000000	
	31	5.321-430.0	Handhold	1.000	ST	0000000000	0000000000	

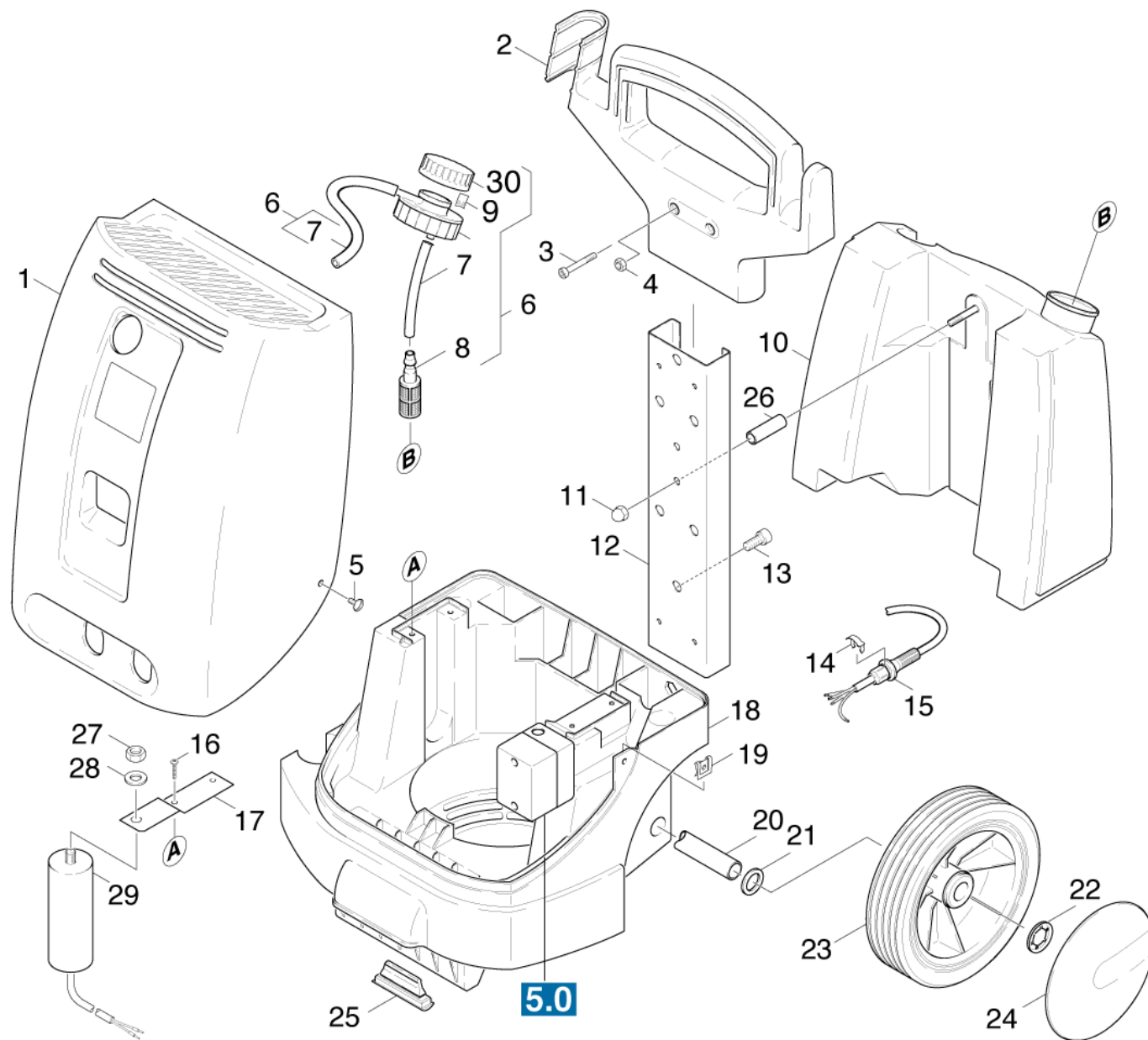

12 Individual parts

ET/VT (spare/wear parts)	Pos	Material #	Name	Qty.	Unit	from ser.nr.	up to ser.nr.
	1	5.067-031.0	Device cover for replacement	1.000	ST	0000000000	0000000000
	2	5.321-423.0	Handhold	1.000	ST	0000000000	0000000000
X	3	7.306-133.0	Screw M6x50 -8.8-R3R (In6Rd)	2.000	ST	0000000000	0000000000
	4	7.311-003.0	Hexagon nut M6 -8-A2E ISO 4032	2.000	ST	0000000000	0000000000
X-X	5	6.304-099.0	Saucer-head screw M 6x 18-4.8-R2R	2.000	ST	0000000000	0000000000
	6	4.580-238.0	Proportioning valve chemistry	1.000	ST	0000000000	0000000000
	7	6.388-216.0	Hose DN 5	1.000	M	0000000000	0000000000
X	8	5.731-652.0	Filter with weight	1.000	ST	0000000000	0000000000
X-X	9	5.337-021.0	Plate spring	1.000	ST	0000000000	0000000000
	10	5.071-069.0	Tank	1.000	ST	0000000000	0000000000
X-X	11	6.310-062.0	Cap nut M 8	1.000	ST	0000000000	0000000000
	12	5.023-117.0	U-Section	1.000	ST	0000000000	0000000000
	13	7.309-015.0	Screw assembly M8x16-8.8-A2E-S4-N ISO106	3.000	ST	0000000000	0000000000
	14	6.343-170.0	Retaining clip	1.000	ST	0000000000	0000000000
	15		Stockpiling discontinued	1.000	ST	0000000000	0000000000
Position text: / 1.951-841.0							
	15		Stockpiling discontinued	1.000	ST	0000000000	0000000000
Position text: / 1.951-801.0							
	16	6.303-174.0	Screw 6,0X20-ST-A2R	2.000	ST	0000000000	0000000000
	17	5.004-695.0	Strap	1.000	ST	0000000000	0000000000
	18	5.605-230.0	Housing	1.000	ST	0000000000	0000000000
X	19	6.310-053.0	Putting nut	2.000	ST	0000000000	0000000000
	20	5.029-229.0	Tube	1.000	ST	0000000000	0000000000
X	21	7.312-060.0	Washer 24-100HV-A3E ISO 7091	2.000	ST	0000000000	0000000000
X-X	22	6.343-217.0	Clamping washer D25	2.000	ST	0000000000	0000000000

12 Individual parts

ET/VT (spare/wear parts)	Pos	Material #	Name	Qty.	Unit	from ser.nr.	up to ser.nr.
	23	6.435-312.0	Wheel D250	2.000	ST	0000000000	0000000000
X-X	24	6.435-197.0	Wheel cap zinc yellow	2.000	ST	0000000000	0000000000
	25	5.057-054.0	Support	2.000	ST	0000000000	0000000000
	26	5.028-703.0	Tube	1.000	ST	0000000000	0000000000
	27	7.311-008.0	Hexagon nut M12-8-A3E ISO 4032	1.000	ST	0000000000	0000000000
	28	7.312-008.0	Washer 12-200HV-A3E ISO 7090	1.000	ST	0000000000	0000000000
	29	6.661-199.0	Capacitor 100MUEF	1.000	ST	0000000000	0000000000
	30	5.321-430.0	Handhold	1.000	ST	0000000000	0000000000

20 Pump set

Pos	Name	Qty.	Unit	from ser.nr.	up to ser.nr.
20	Cylinder head	1.000	ST	0000000000	0000000000
21	Valves	1.000	ST	0000000000	0000000000
22	Piston	1.000	ST	0000000000	0000000000
23	Chemistry	1.000	ST	0000000000	0000000000

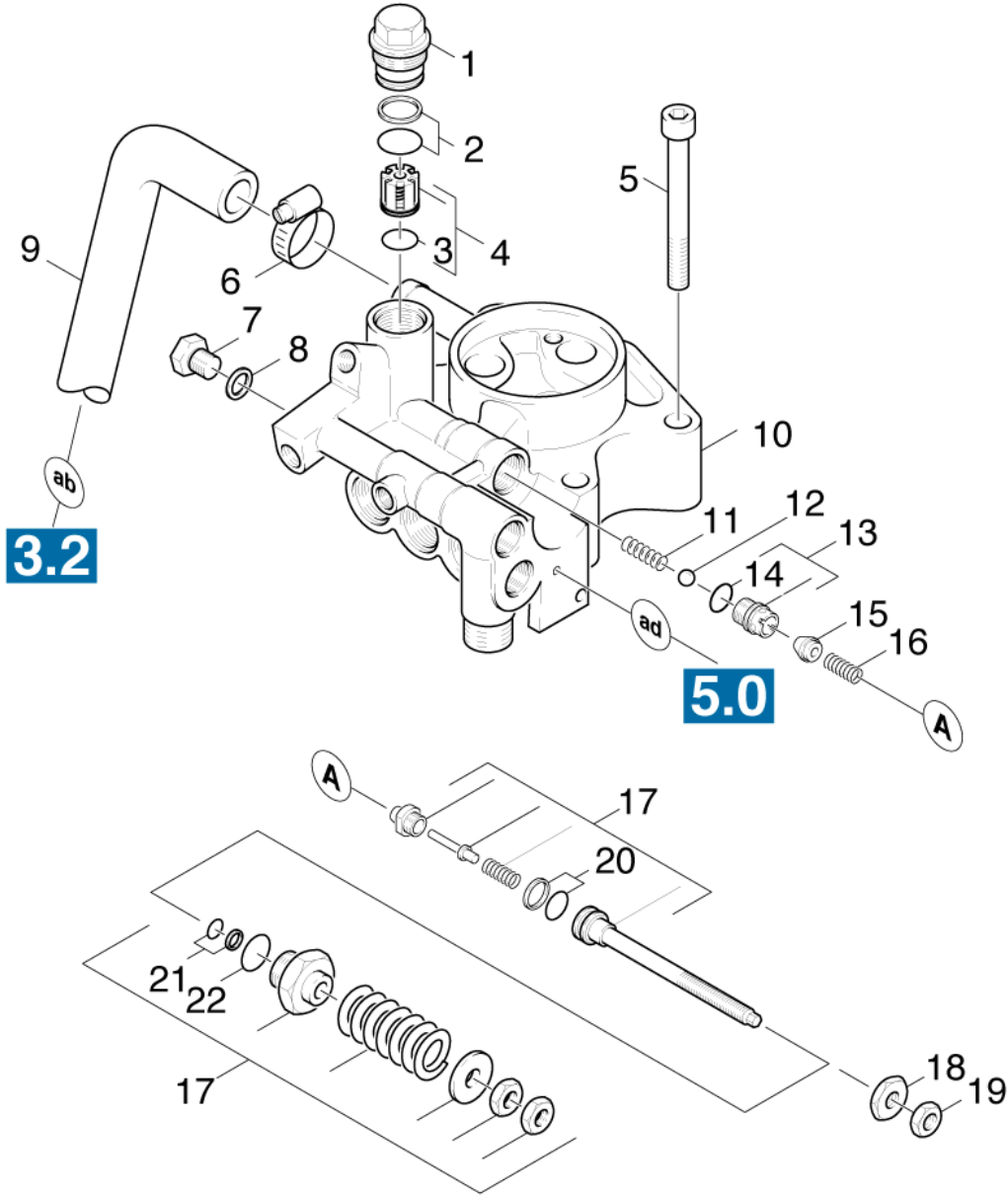

20 Cylinder head

ET/VT (spare/wear parts)	Pos	Material #	Name	Qty.	Unit	from ser.nr.	up to ser.nr.
X	1	5.583-125.0	Valve screw	1.000	ST	0000000000	0000000000
X-X	2	6.362-500.0	O-Ring seal complete /1ST.-R.	1.000	ST	0000000000	0000000000
X-X	3	6.362-381.0	O-Ring seal 13x2 - NBR 70	1.000	ST	0000000000	0000000000
X-X	4	4.580-262.0	Valve complete	1.000	ST	0000000000	0000000000
X-X	5	7.306-091.0	Cylinder head screw M12x90- 8.8-A3E ISO	4.000	ST	0000000000	0000000000
X-X	6	6.388-547.0	Hose clip	1.000	ST	0000000000	0000000000
	7	5.411-117.0	Screw plug	1.000	ST	0000000000	0000000000
X-X	8	7.362-004.0	Joint ring A12x15,5 -Cu DIN 7603	1.000	ST	0000000000	0000000000
X-X	9	5.442-833.0	Piece of tube	1.000	ST	0000000000	0000000000
	10	5.550-187.0	Cylinder head	1.000	ST	0000000000	0000000000
X-X	11	5.332-999.0	Helical spring	1.000	ST	0000000000	0000000000
X-X	12	7.401-907.0	Sphere 3/8 G200-1.4301 DIN 5401	1.000	ST	0000000000	0000000000
	13	4.581-022.0	Valve seat complete	1.000	ST	0000000000	0000000000
X-X	14	6.362-858.0	O-Ring seal 11,0 X 1,5	1.000	ST	0000000000	0000000000
	15	5.581-199.0	Valve seat	1.000	ST	0000000000	0000000000
X-X	16	5.332-366.0	Helical spring	1.000	ST	0000000000	0000000000
	17	4.591-031.0	Overflow valve	1.000	ST	0000000000	0000000000
	18	5.311-177.0	Hexagon nut	1.000	ST	0000000000	0000000000
X	19	7.311-004.0	Hexagon nut M8 -8-A3E ISO 4032	1.000	ST	0000000000	0000000000
X-X	20	6.362-575.0	O-Ring seal 12,42 KOMPL	1.000	ST	0000000000	0000000000
X-X	21	6.362-365.0	O-Ring seal complete 1ST.-R.- 7,65X 1,7	1.000	ST	0000000000	0000000000
X-X	22	6.362-153.0	O-Ring seal 15,3 X 2,4-NBR 70	1.000	ST	0000000000	0000000000

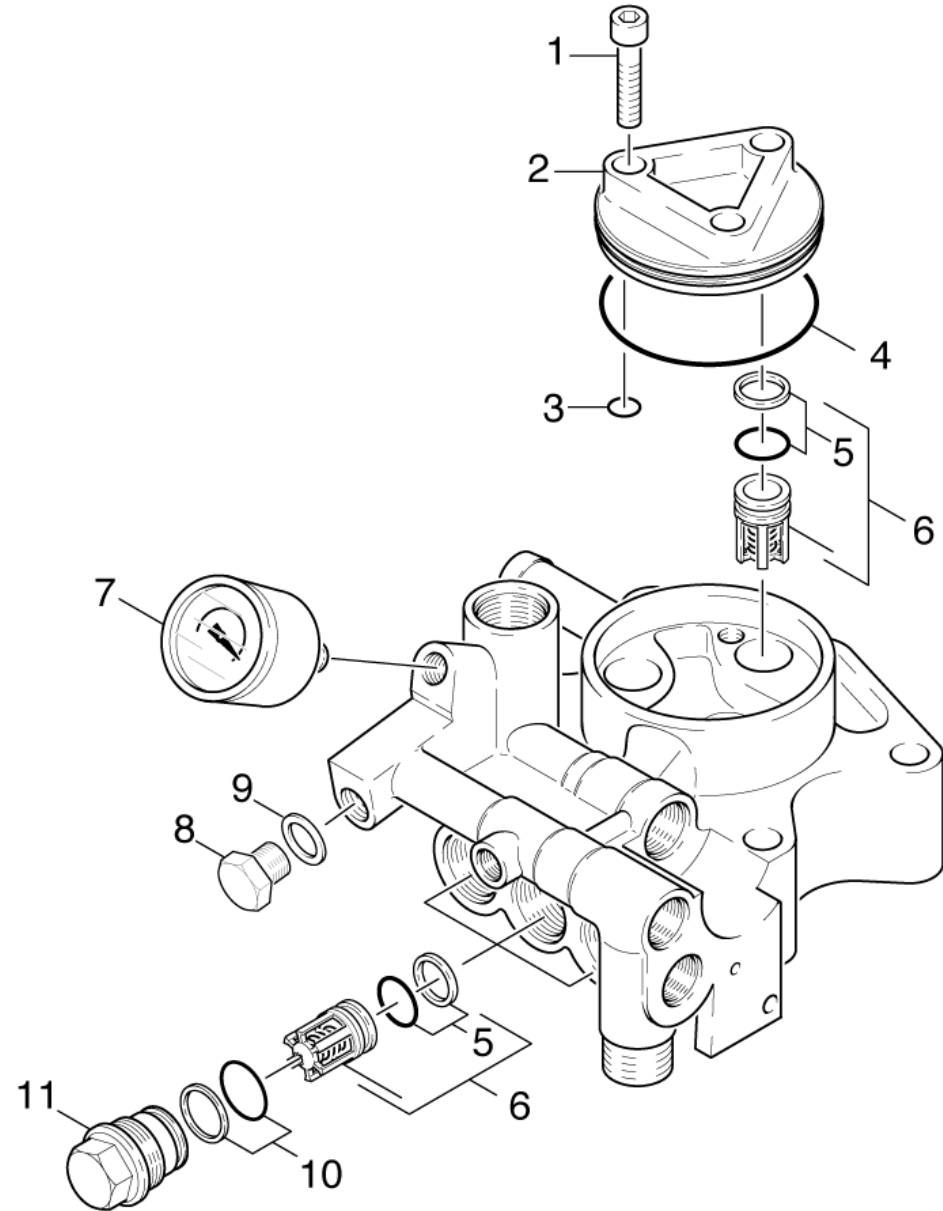

21 Valves

ET/VT (spare/wear parts)	Pos	Material #	Name	Qty.	Unit	from ser.nr.	up to ser.nr.
	1	7.306-074.0	Cylinder head screw M10x35-8.8-A3E ISO4	3.000	ST	0000000000	0000000000
	2	5.063-611.0	Cover housing	1.000	ST	0000000000	0000000000
	3	6.362-577.0	O-Ring seal 11,0 X 1,5-NBR 70	3.000	ST	0000000000	0000000000
X-X	4	6.362-501.0	O-Ring seal 68,0 X 2,0-NBR 70	1.000	ST	0000000000	0000000000
X-X	5	4.363-693.0	O-Ring seal kpl. -nur fuer Ersatz-	6.000	ST	0000000000	0000000000
X-X	6	2.884-906.0	Válvula triple (3 stueck)	2.000	ST	0000000000	0000000000
X-X	7	6.421-214.0	Pressure gauge 0-300 BAR	1.000	ST	0000000000	0000000000
	8	5.411-117.0	Screw plug	1.000	ST	0000000000	0000000000
X-X	9	7.362-004.0	Joint ring A12x15,5 -Cu DIN 7603	1.000	ST	0000000000	0000000000
X-X	10	6.362-500.0	O-Ring seal complete /1ST.-R.	3.000	ST	0000000000	0000000000
X	11	5.583-125.0	Valve screw	3.000	ST	0000000000	0000000000

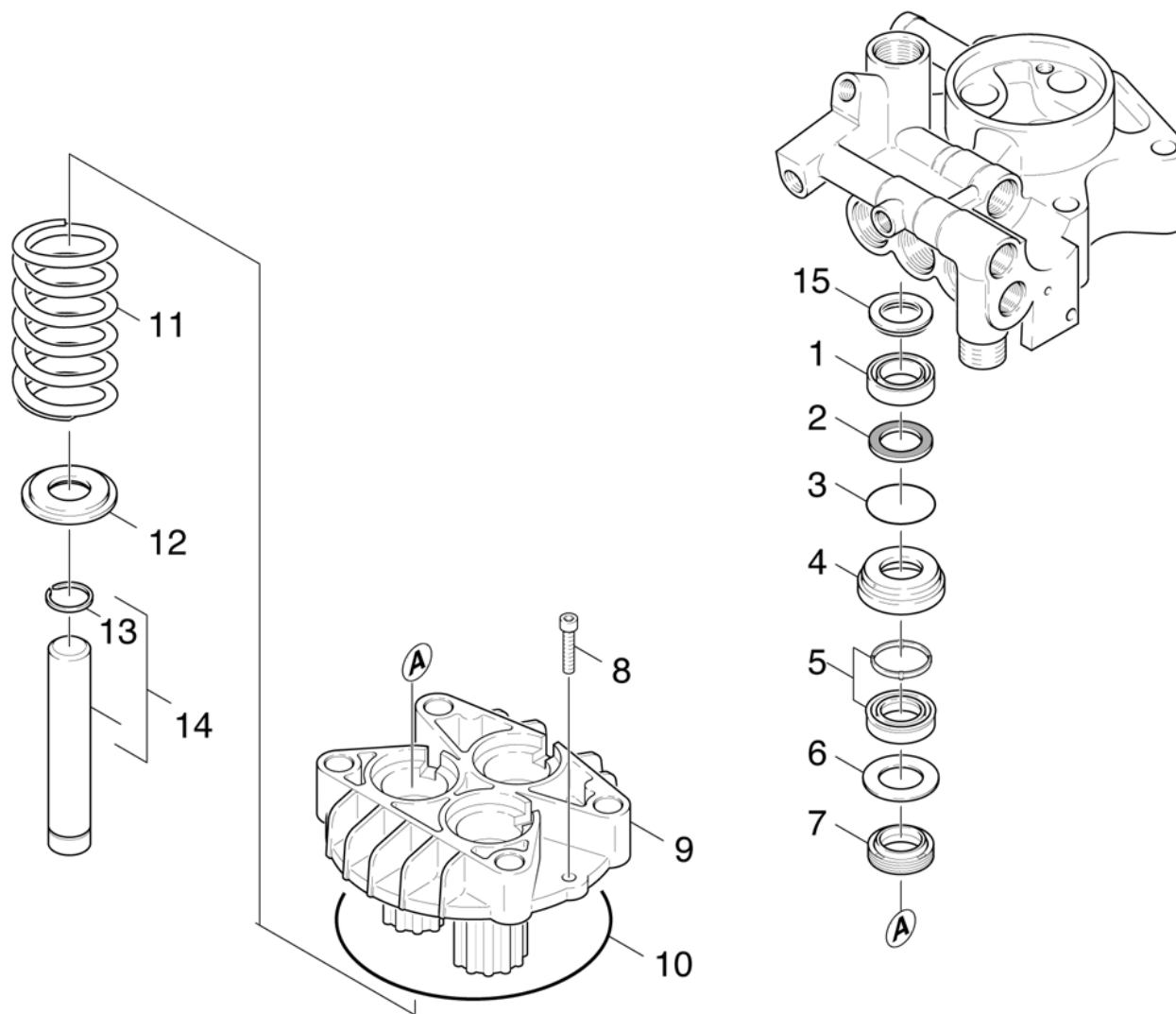

22 Piston

ET/VT (spare/wear parts)	Pos	Material #	Name	Qty.	Unit	from ser.nr.	up to ser.nr.
X-X	1	6.365-377.0	Grooved ring 20x30x6	3.000	ST	0000000000	0000000000
X-X	2	6.365-379.0	Supportring	3.000	ST	0000000000	0000000000
X-X	3	6.362-484.0	O-Ring seal 34,65X 1,78	3.000	ST	0000000000	0000000000
X-X	4	5.112-451.0	Bush	3.000	ST	0000000000	0000000000
X-X	5	6.365-380.0	Set of gaskets low-pressure	3.000	ST	0000000000	0000000000
X-X	6	5.115-537.0	Washer	3.000	ST	0000000000	0000000000
X-X	7	6.365-052.0	Grooved ring 20X28X6/8	3.000	ST	0000000000	0000000000
X	8	7.306-023.0	Cylinder head screw M6x25 -8.8-A2E ISO4	2.000	ST	0000000000	0000000000
	9	5.060-460.0	Housing thrust guidance	1.000	ST	0000000000	0000000000
X-X	10	6.362-796.0	O-Ring seal 107,62X 2,62	1.000	ST	0000000000	0000000000
X-X	11	5.332-281.0	Helical spring	3.000	ST	0000000000	0000000000
X-X	12	5.115-539.0	Washer	3.000	ST	0000000000	0000000000
X-X	13	6.472-331.0	Snap ring 20	3.000	ST	0000000000	0000000000
	14	4.553-152.0	Piston complete only for replacement	3.000	ST	0000000000	0000000000
X-X	15	6.365-378.0	Supportring 20x30x4,2	3.000	ST	0000000000	0000000000

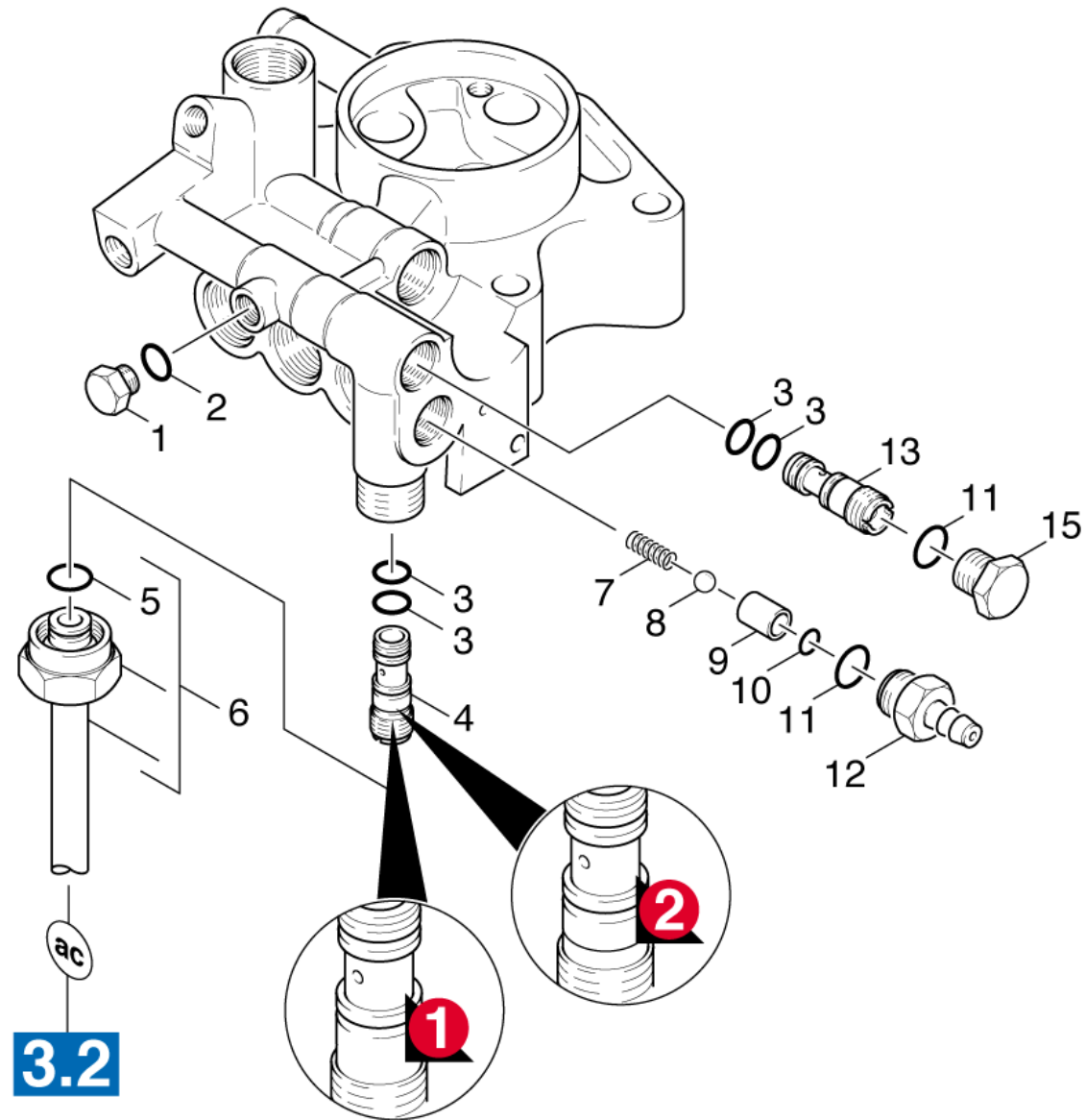

23 Chemistry

ET/VT (spare/wear parts)	Pos	Material #	Name	Qty.	Unit	from ser.nr.	up to ser.nr.	var. information
X-X	1	5.411-070.0	Screw plug	1.000	ST	0000000000	0000000000	
	2	6.362-101.0	O-Ring seal 8 X 2	1.000	ST	0000000000	0000000000	
X-X	3	6.362-384.0	O-Ring seal 9x1,5 - NBR 70	4.000	ST	0000000000	0000000000	
X-X	4	5.769-082.0	Nozzle insert D2.0/ D2.7/ L38	1.000	ST	0000000000	0000000000	VERSION 1
	4	5.769-079.0	Nozzle insert D1.8/ D2.7/ L38	1.000	ST	0000000000	0000000000	VERSION 2
X-X	5	2.880-154.0	O-Ring kit	1.000	ST	0000000000	0000000000	
	6	4.025-359.0	Pipeline high-pressure	1.000	ST	0000000000	0000000000	
	7	5.332-258.0	Helical spring	1.000	ST	0000000000	0000000000	
	8	7.401-908.0	Sphere 7 G300 -1.4301 DIN 5401	1.000	ST	0000000000	0000000000	
X	9	5.026-764.0	Tube	1.000	ST	0000000000	0000000000	
X-X	10	6.362-383.0	O-Ring seal 6,0 X 2,0	1.000	ST	0000000000	0000000000	
X-X	11	6.362-533.0	O-Ring seal 14,0 X 1,5-NBR 70	1.000	ST	0000000000	0000000000	
	12	5.402-370.0	Screw union	1.000	ST	0000000000	0000000000	
	13	5.769-122.0	Nozzle insert D2.4/ D3.2/ L38	1.000	ST	0000000000	0000000000	
X-X	14	6.362-527.0	O-Ring seal 12,0 X 1,5-NBR 70	1.000	ST	0000000000	0000000000	
	15	5.411-107.0	Screw plug	1.000	ST	0000000000	0000000000	

30 Motor

Pos	Name	Qty.	Unit	from ser.nr.	up to ser.nr.
30	Transmission	1.000	ST	0000000000	0000000000
31	Ventilation	1.000	ST	0000000000	0000000000

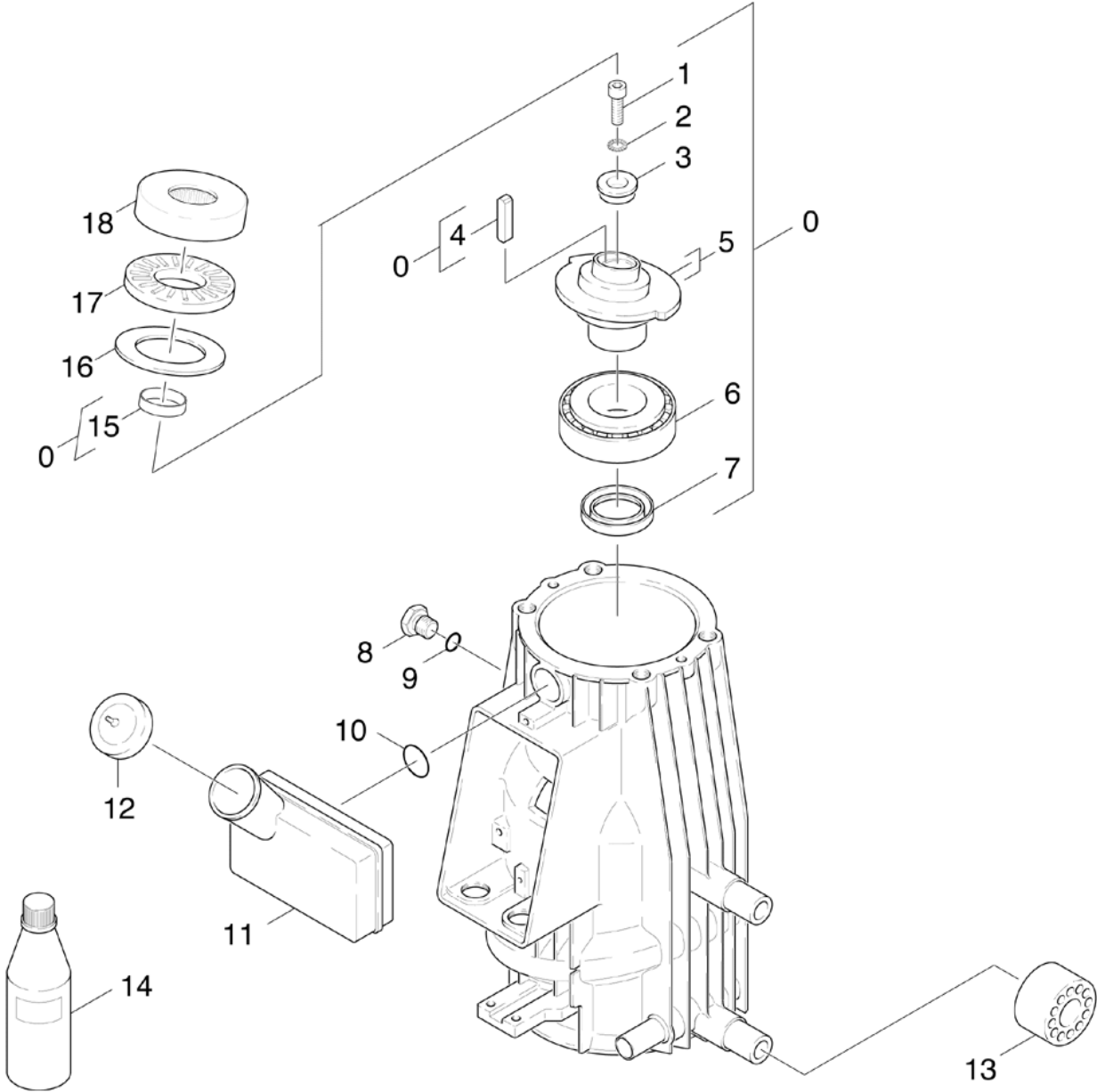

30 Transmission

ET/VT (spare/wear parts)	Pos	Material #	Name	Qty.	Unit	from ser.nr.	up to ser.nr.
	0	4.623-280.0	Motor 4,5KW	1.000	ST	0000000000	0000000000
X-X	1	7.306-041.0	Cylinder head screw M8x20 -8.8-A2E ISO	1.000	ST	0000000000	0000000000
X-X	2	7.312-166.0	Toothed lock washer A8,4-FSt-A3E DIN 67	1.000	ST	0000000000	0000000000
	3	5.115-540.0	Washer	1.000	ST	0000000000	0000000000
	4	7.318-089.0	Parallel key A 8x5x25-C45R DIN 6885	1.000	ST	0000000000	0000000000
	5	4.120-164.0	Wobble plate complete only for replaceme	1.000	ST	0000000000	0000000000
X-X	6	6.401-225.0	Taper roller bearing 41	1.000	ST	0000000000	0000000000
X-X	7	7.367-009.0	Radial shaft seal ring A35x52x7-NBR DIN	1.000	ST	0000000000	0000000000
	8	5.411-100.0	Screw plug	1.000	ST	0000000000	0000000000
	9	6.363-273.0	O-Ring seal 11,0 x 2,0	1.000	ST	0000000000	0000000000
X-X	10	6.362-161.0	O-Ring seal 19,3 X 2,4	1.000	ST	0000000000	0000000000
	11	5.070-457.0	Tank oil	1.000	ST	0000000000	0000000000
X-X	12	5.063-389.0	Cover	1.000	ST	0000000000	0000000000
	13	5.057-055.0	Support	4.000	ST	0000000000	0000000000
X-X	14	6.288-050.0	Engine oil 1L	1.000	ST	0000000000	0000000000
	15	6.401-121.0	Ring inside	1.000	ST	0000000000	0000000000
	16	6.401-122.0	Rotor disc	1.000	ST	0000000000	0000000000
	17	6.401-123.0	Axial roller cage	1.000	ST	0000000000	0000000000
X	18	6.401-124.0	Thrust washer with cage	1.000	ST	0000000000	0000000000

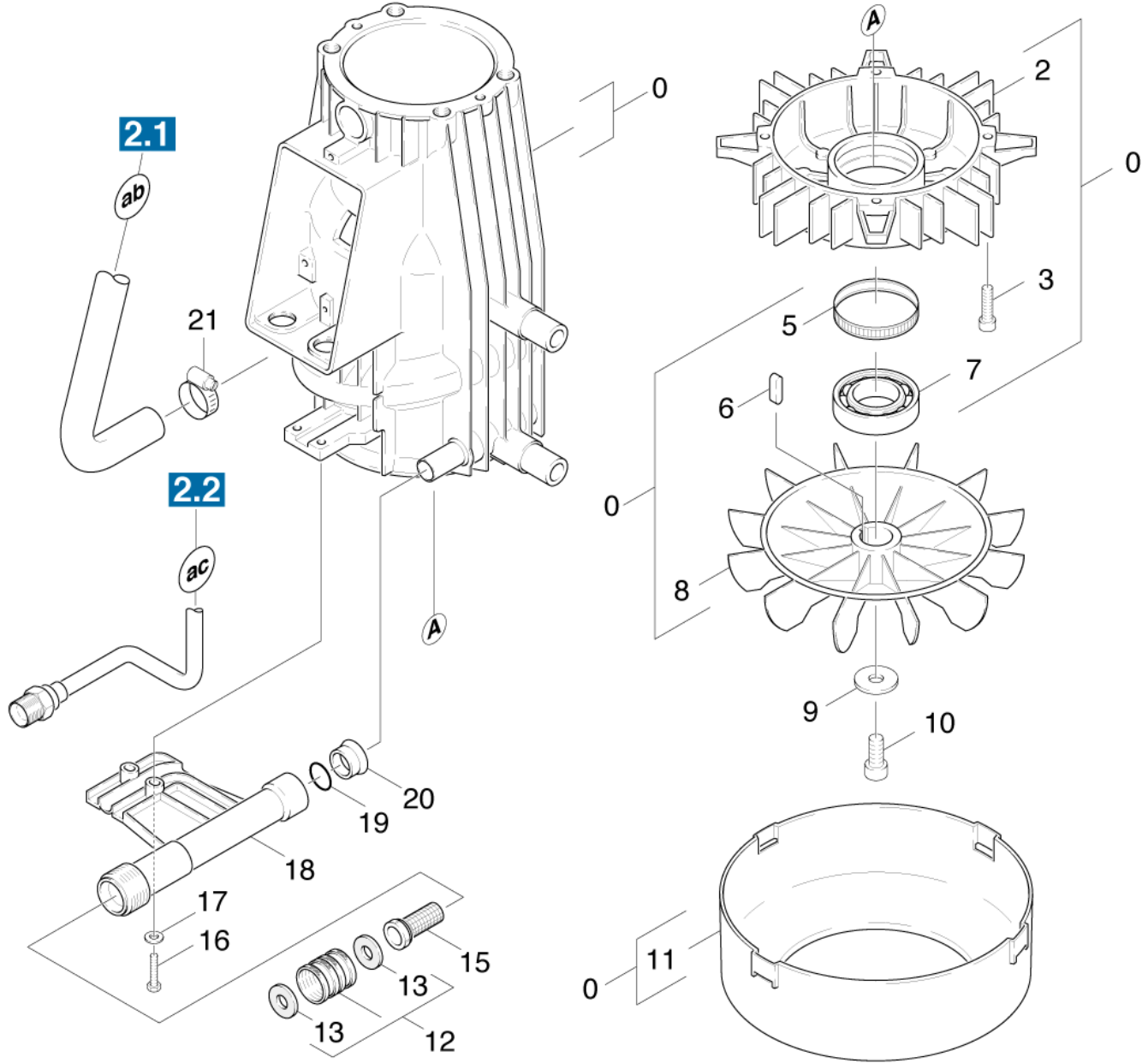

31 Ventilation

ET/VT (spare/wear parts)	Pos	Material #	Name	Qty.	Unit	from ser.nr.	up to ser.nr.
	0	4.623-280.0	Motor 4,5KW	1.000	ST	0000000000	0000000000
	2	5.063-518.0	Cover	1.000	ST	0000000000	0000000000
	3	7.303-048.0	Screw M6x20 -St-R3R (In6Rd)	4.000	ST	0000000000	0000000000
X-X	5	6.343-010.0	Tolerance ring 62x10	1.000	ST	0000000000	0000000000
	6	7.318-029.0	Parallel key 6x6x20-C45R DIN 6885	1.000	ST	0000000000	0000000000
X-X	7	6.401-253.0	Ball bearing 6305-2Z	1.000	ST	0000000000	0000000000
	8	6.611-605.0	Blower wheel	1.000	ST	0000000000	0000000000
	9	5.115-565.0	Washer	1.000	ST	0000000000	0000000000
X-X	10	7.306-041.0	Cylinder head screw M8x20 -8.8-A2E ISO	1.000	ST	0000000000	0000000000
	11	5.692-026.0	Air circulation	1.000	ST	0000000000	0000000000
	12	6.386-463.0	Screw connector	1.000	ST	0000000000	0000000000
	13	5.364-129.0	Flat gasket	2.000	ST	0000000000	0000000000
X-X	15	6.414-141.0	Strainer	1.000	ST	0000000000	0000000000
X	16	7.304-386.0	Hexagonal head screw M 6x25-8.8-A2E ISO	2.000	ST	0000000000	0000000000
X-X	17	7.312-003.0	Washer 6 -200HV-A3E ISO 7090	2.000	ST	0000000000	0000000000
	18	5.427-192.0	Manifold	1.000	ST	0000000000	0000000000
X-X	19	6.362-579.0	O-Ring seal 17,5 X 3,5	1.000	ST	0000000000	0000000000
X-X	20	5.110-341.0	Sleeve	1.000	ST	0000000000	0000000000
X-X	21	6.388-548.0	Hose clip	1.000	ST	0000000000	0000000000

40 Accessories

Pos	Name	Qty.	Unit	from ser.nr.	up to ser.nr.	var. information
41	Hand trigger gun	1.000	ST	0000000000	0000000000	VERSION 1
42	Hand trigger gun	1.000	ST			VERSION 2
43	Jet pipe	1.000	ST	0000000000	0000000000	VERSION 1
44	Jet pipe	1.000	ST	0000000000	0000000000	VERSION 2
45	Nozzle	1.000	ST	0000000000	0000000000	

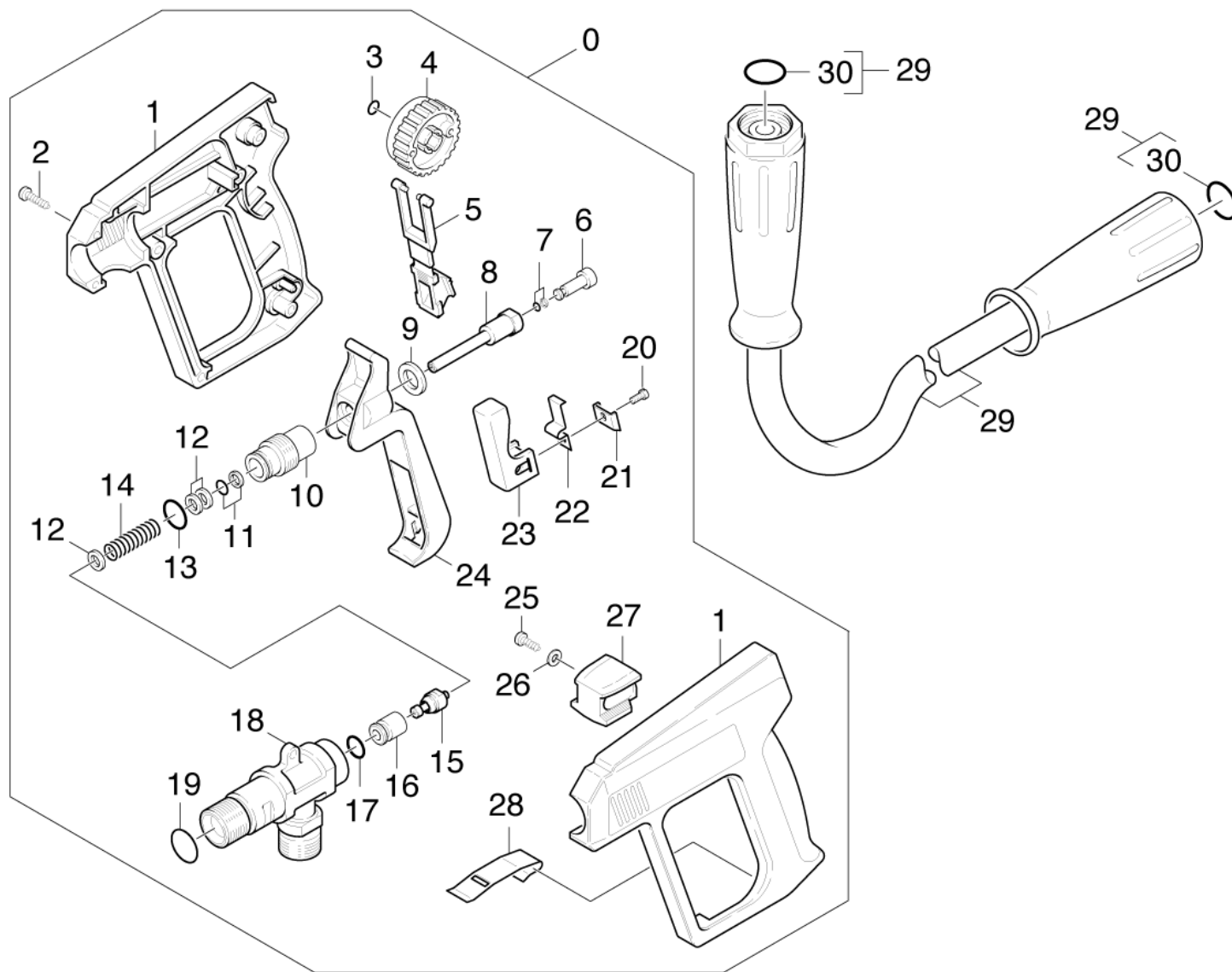

41 Hand trigger gun

ET/VT (spare/wear parts)	Pos	Material #	Name	Qty.	Unit	from ser.nr.	up to ser.nr.
	0		Stockpiling discontinued	1.000	ST	0000000000	0000000000
	1	5.321-107.0	Handhold few	1.000	ST	0000000000	0000000000
	2	7.303-096.0	Screw 4x22 -ST-10.9-R2R (IN6RD)	8.000	ST	0000000000	0000000000
X	3	6.362-176.0	O-Ring seal 6,07x1,78	1.000	ST	0000000000	0000000000
	4	5.322-006.0	Hand wheel	1.000	ST	0000000000	0000000000
	5	5.030-283.0	Moulded part	1.000	ST	0000000000	0000000000
	6	5.553-118.0	Piston	1.000	ST	0000000000	0000000000
X-X	7	6.362-477.0	O-Ring seal complete 1ST.-R.	1.000	ST	0000000000	0000000000
	8	5.107-062.0	Bar	1.000	ST	0000000000	0000000000
	9	5.115-227.0	Washer	1.000	ST	0000000000	0000000000
	10	5.305-110.0	Shaped screw	1.000	ST	0000000000	0000000000
X-X	11	6.362-468.0	O-Ring seal complete 1ST.-R.	1.000	ST	0000000000	0000000000
	12	5.115-260.0	Washer	3.000	ST	0000000000	0000000000
	13	6.362-478.0	O-Ring seal 12,42X 1,78	1.000	ST	0000000000	0000000000
	14	5.332-140.0	Helical spring	1.000	ST	0000000000	0000000000
	15	4.581-013.0	Valve seat	1.000	ST	0000000000	0000000000
	16	5.110-217.0	Sleeve	1.000	ST	0000000000	0000000000
	17	6.362-479.0	O-Ring seal 7,59X 2,62	1.000	ST	0000000000	0000000000
	18	5.427-079.0	Manifold	1.000	ST	0000000000	0000000000
	19	6.362-496.0	O-Ring seal 17,12X 2,62-NBR 70	1.000	ST	0000000000	0000000000
	20	6.303-058.0	Oval head screw 2,9X 13-ST-VERZ	1.000	ST	0000000000	0000000000
	21	5.040-480.0	Sheet metal component	1.000	ST	0000000000	0000000000
	22	5.335-013.0	Spiral spring	1.000	ST	0000000000	0000000000
	23	5.325-010.0	Lever	1.000	ST	0000000000	0000000000
	24	5.325-009.0	Lever	1.000	ST	0000000000	0000000000

41 Hand trigger gun

ET/VT (spare/wear parts)	Pos	Material #	Name	Qty.	Unit	from ser.nr.	up to ser.nr.
	25	6.303-025.0	Oval head screw 4,2x16-St-vz	1.000	ST	0000000000	0000000000
X	26	7.312-001.0	Washer 4 -200HV-A3E ISO 7089	1.000	ST	0000000000	0000000000
	27	5.030-321.0	Moulded part	1.000	ST	0000000000	0000000000
	28	5.040-479.0	Sheet metal component	1.000	ST	0000000000	0000000000
X-X	29	6.390-010.0	Hose assembly rotatable DN8 max.31,5MPa	1.000	ST	0000000000	0000000000
X-X	30	2.880-990.0	Spare part set O-Ring 5x -Kaercher	1.000	ST	0000000000	0000000000

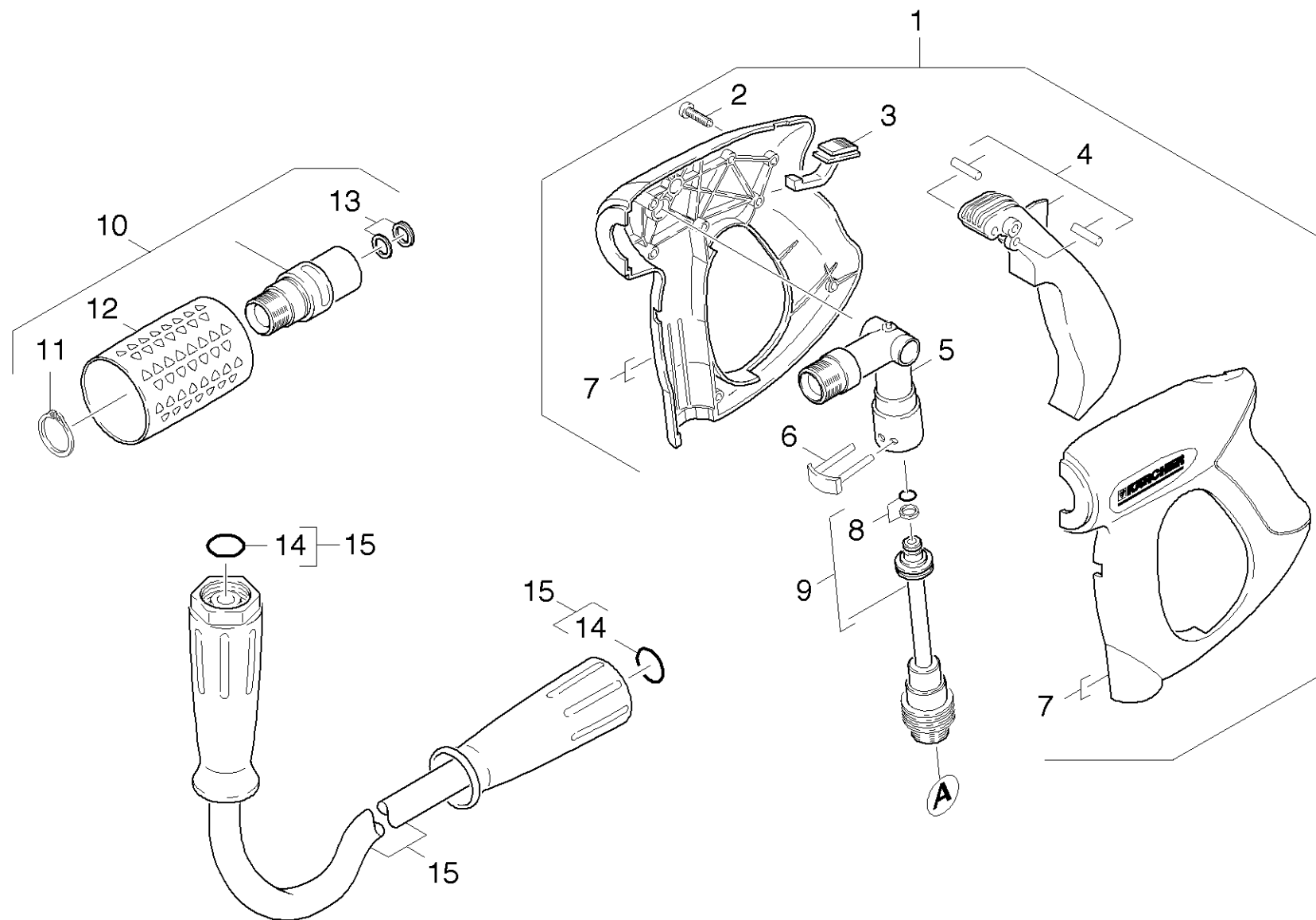

42 Hand trigger gun

ET/VT (spare/wear parts)	Pos	Material #	Name	Qty.	Unit
X-X	1	4.775-466.0	Hand trigger gun	1.000	ST
	2	7.303-096.0	Screw 4x22 -ST-10.9-R2R (IN6RD)	7.000	ST
	3	5.481-331.0	Slider	1.000	ST
X	4	4.481-209.0	Lever complete	1.000	ST
X-X	5	4.427-215.0	Manifold complete only for replacement	1.000	ST
X-X	6	4.037-013.0	Hook	1.000	ST
X	7	5.321-669.0	Handhold few	2.000	ST
X-X	8	4.363-691.0	O-Ring seal kpl. -nur fuer Ersatz-	1.000	ST
X-X	9	4.421-739.0	Adapter pipelines AVS-M22x1,5	1.000	ST
X-X	10	4.775-470.0	Rotary controller 416L	1.000	ST
X-X	11	7.343-008.0	Locking ring 25x1,2-St-vz DIN 471	1.000	ST
X	12	5.321-668.0	Handle	1.000	ST
X-X	13	4.363-695.0	Grooved ring only for replacement	1.000	ST
X-X	14	2.880-990.0	Spare part set O-Ring 5x -Kaercher	1.000	ST
X-X	15	6.390-010.0	Hose assembly rotatable DN8 max.31,5MPa	1.000	ST

13 Grooved ring only for replacement (4.363-695.0)

ET/VT (spare/wear parts)	Pos	Material #	Name	Qty.	Unit
X-X	1	6.363-310.0	Grooved ring 14x9,4x2,6	1.000	ST
X-X	2	6.590-004.0	Bag PE 80x100 mm	1.000	ST
	3	6.376-036.0	Label spare parts neutrally 65x55 MM	1.000	ZST

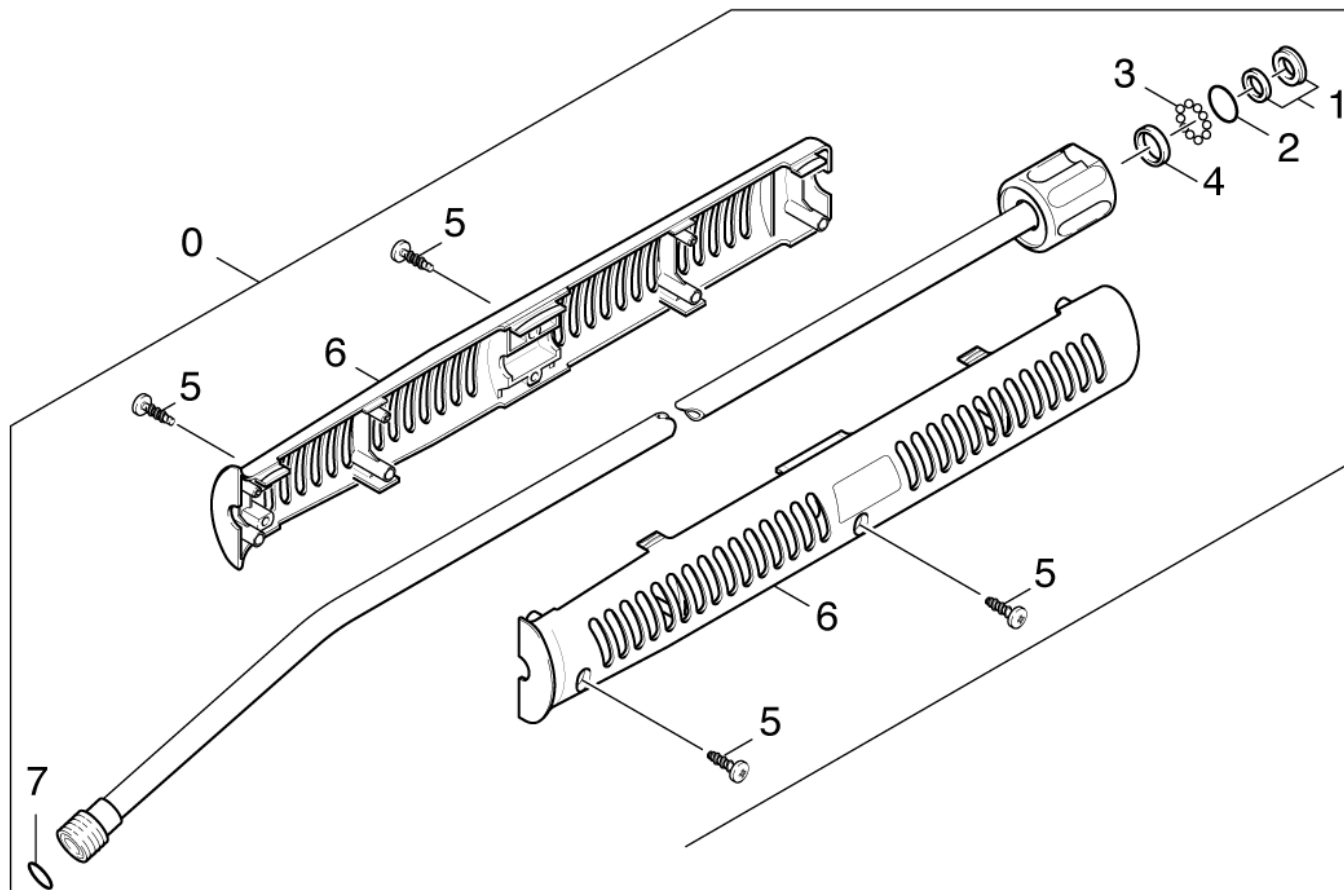

43 Jet pipe

ET/VT (spare/wear parts)	Pos	Material #	Name	Qty.	Unit	from ser.nr.	up to ser.nr.
X-X	0	4.760-660.0	Jet pipe packaged only for replacement	1.000	ST	0000000000	0000000000
X-X	1	4.363-692.0	Grooved ring kpl. -nur fuer Ersatz-	1.000	ST	0000000000	0000000000
X-X	2	6.362-524.0	O-Ring seal 17,0 X 1,5	1.000	ST	0000000000	0000000000
X-X	3	7.401-921.0	Sphere 4 G20 -1.4034 DIN 5401	12.000	ST	0000000000	0000000000
	4	6.362-529.0	Joint ring 12x1,5	1.000	ST	0000000000	0000000000
	5	6.303-025.0	Oval head screw 4,2x16-St-vz	4.000	ST	0000000000	0000000000
	6	5.321-150.0	HANDLE (PART NO=ONE HALF)	2.000	ST	0000000000	0000000000
X-X	7	2.880-990.0	Spare part set O-Ring 5x -Kaercher	1.000	ST	0000000000	0000000000

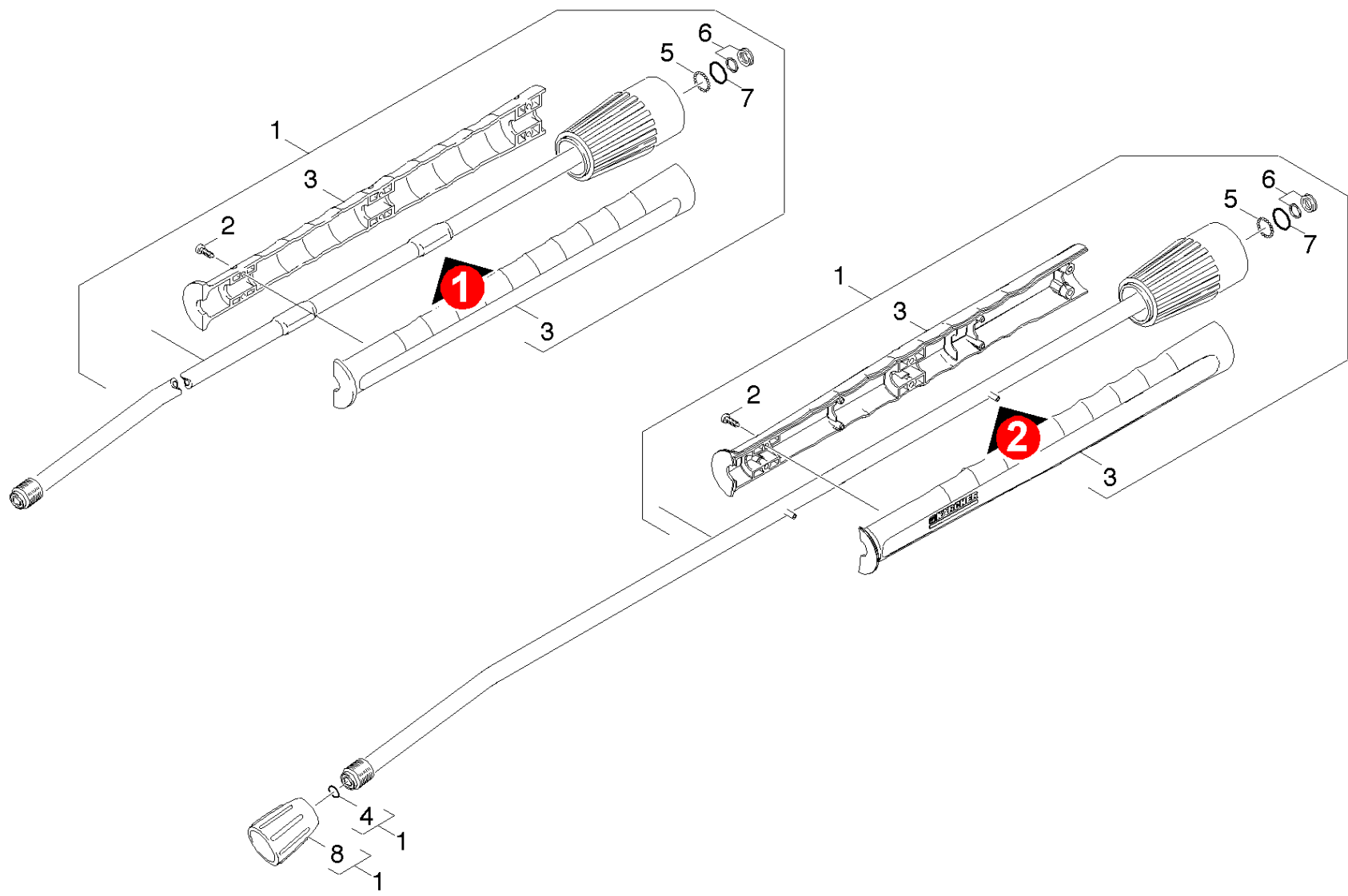

44 Jet pipe

ET/VT (spare/wear parts)	Pos	Material #	Name	Qty.	Unit	from ser.nr.	up to ser.nr.	var. information
X-X	1	4.760-660.0	Jet pipe packaged only for replacement	1.000	ST	0000000000	0000000000	
X	2	7.303-129.0	Screw 4x16 -10.9-R2R (K-In6Rd)	6.000	ST	0000000000	0000000000	
X-X	3	5.321-855.0	Handhold few jet pipe with welding bolt	1.000	ST			VERSION 2
	3	5.321-691.0	Handhold few jet pipe	1.000	ST	0000000000	0000000000	VERSION 1
X-X	4	2.880-990.0	Spare part set O-Ring 5x -Kaercher	1.000	ST	0000000000	0000000000	
X-X	5	7.401-915.0	Sphere 2,5 G20 -1.4034 DIN 5401	20.000	ST	0000000000	0000000000	
X-X	6	4.363-692.0	Grooved ring kpl. -nur fuer Ersatz-	1.000	ST	0000000000	0000000000	
X-X	7	6.362-524.0	O-Ring seal 17,0 X 1,5	1.000	ST	0000000000	0000000000	
X-X	8	5.401-129.0	Screw connector part	1.000	ST	0000000000	0000000000	

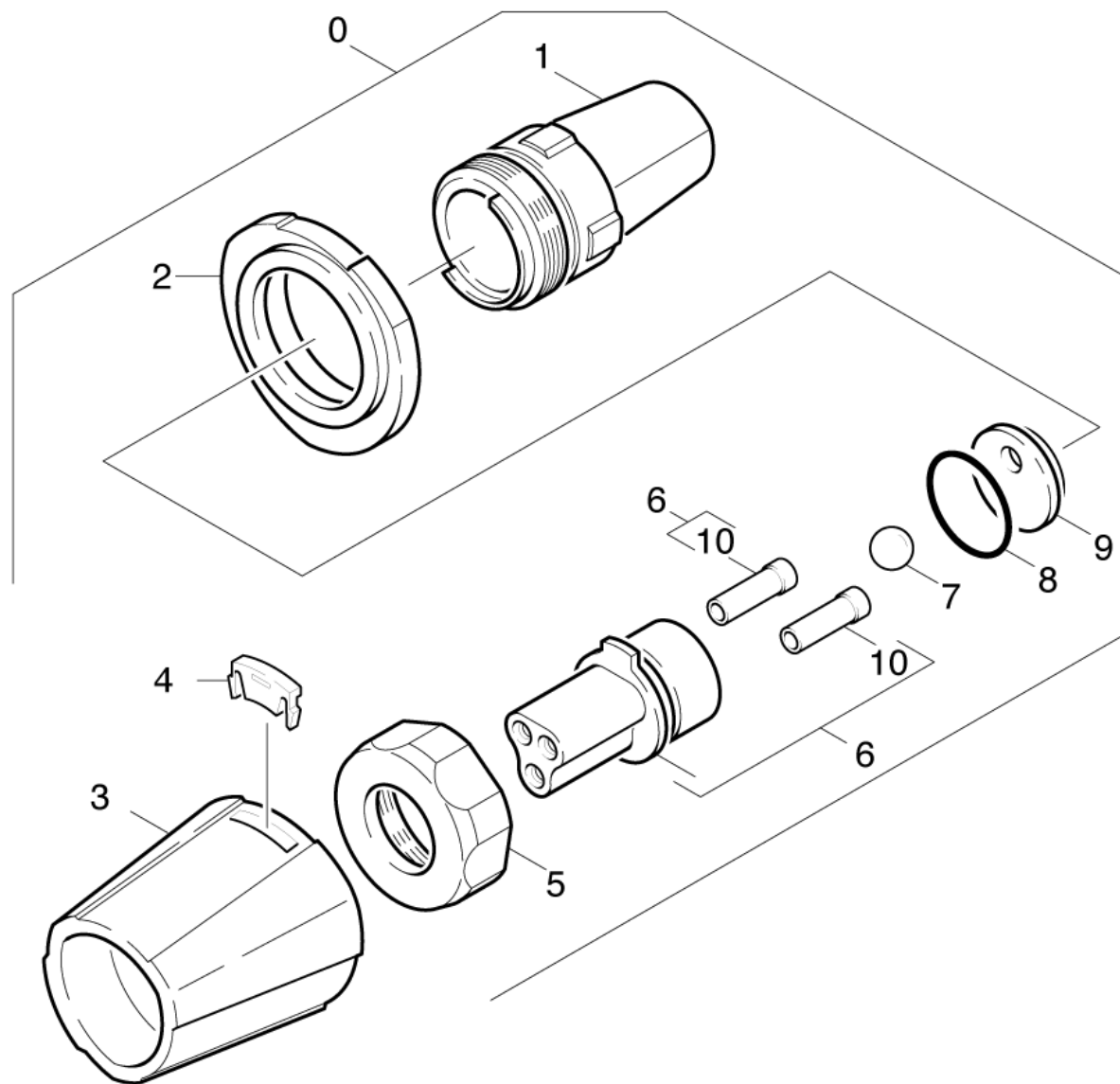

45 Nozzle

ET/VT (spare/wear parts)	Pos	Material #	Name	Qty.	Unit	from ser.nr.	up to ser.nr.
X-X	0	4.767-067.0	Triple jet nozzle 06	1.000	ST	0000000000	0000000000
	1	4.060-395.0	Housing complete only for replacement	1.000	ST	0000000000	0000000000
	2	5.394-401.0	Protection part	1.000	ST	0000000000	0000000000
	3	5.394-402.0	Protection part	1.000	ST	0000000000	0000000000
	4	5.031-709.0	Moulded part	1.000	ST	0000000000	0000000000
	5	5.311-192.0	Union nut	1.000	ST	0000000000	0000000000
	6		Stockpiling discontinued	1.000	ST	0000000000	0000000000
	7	7.401-917.0	Sphere 10,0 G100-1.4301 DIN 5401	1.000	ST	0000000000	0000000000
	8	6.362-831.0	O-Ring d. 22x2 NBR 90	1.000	ST	0000000000	0000000000
	9	5.031-370.0	Moulded part	1.000	ST	0000000000	0000000000
	10	5.031-597.0	Rectifier	2.000	ST	0000000000	0000000000

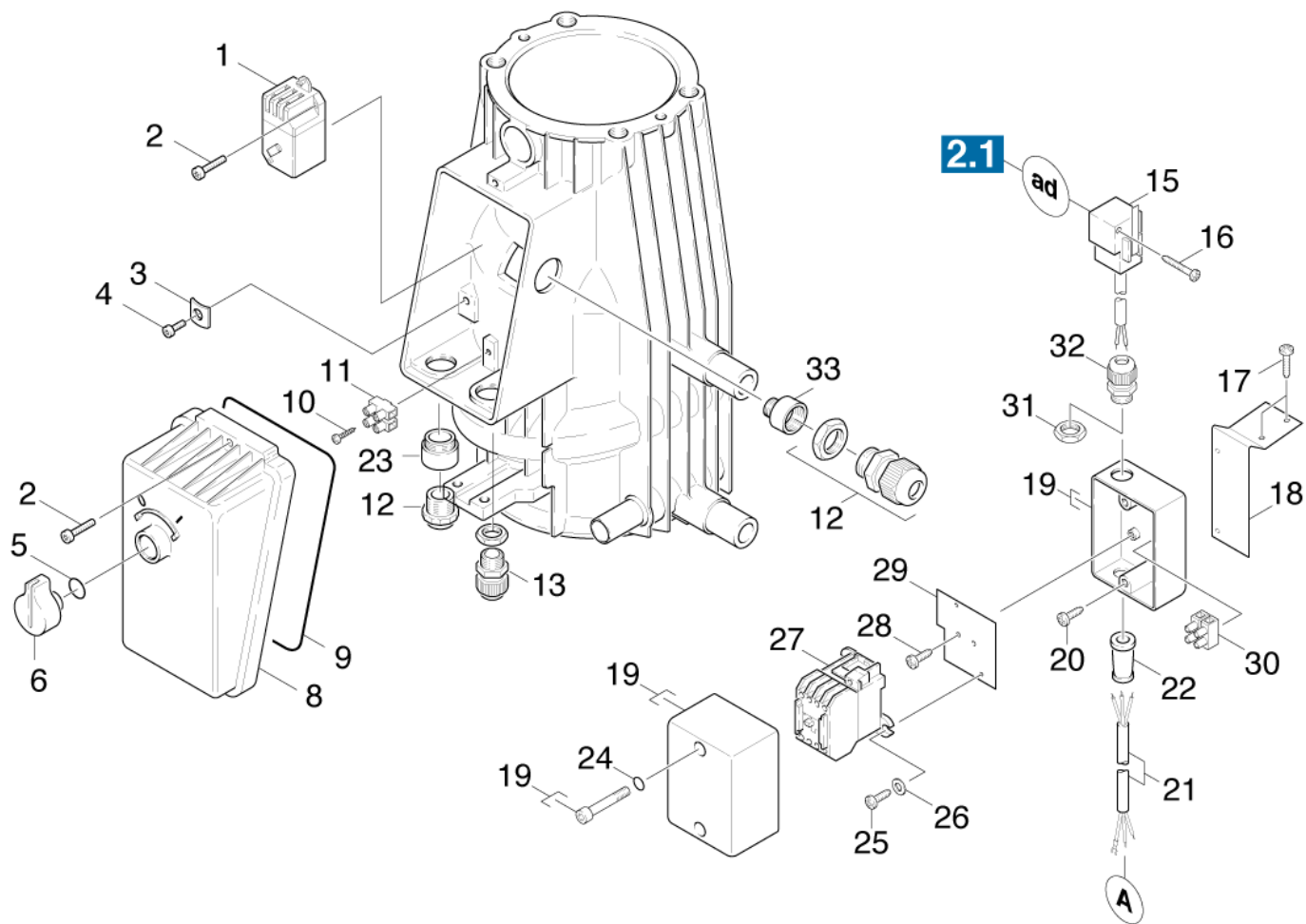

50 Electric control box

ET/VT (spare/wear parts)	Pos	Material #	Name	Qty.	Unit	from ser.nr.	up to ser.nr.	Footnote text
	1	6.631-242.0	Motor protecting switch	1.000	ST	0000000000	0000000000	
	2	7.309-016.0	Screw M4x22-Z7-1 -4.8-A2E DIN6900	3.000	ST	0000000000	0000000000	
	3	6.641-708.0	Clamping washer 5	1.000	ST	0000000000	0000000000	
	4	7.303-039.0	Screw M5x16 -St-A2R (In6Rd)	1.000	ST	0000000000	0000000000	
	5	6.472-112.0	O-Ring seal 10,0 x 2,4 NBR 70	1.000	ST	0000000000	0000000000	
X-X	6	5.321-556.0	Handhold	1.000	ST	0000000000	0000000000	
	8	5.066-756.0	Cover	1.000	ST	0000000000	0000000000	
	9	6.273-070.0	Seal string cellular rubber 4	1.000	M	0000000000	0000000000	TO ORDER AS CUT GOODS
	10	7.303-501.0	Self-tapping screw M3x20-ST-A2E DIN 7500	1.000	ST	0000000000	0000000000	
	11	6.643-151.0	Strip terminal one-pole 16mm ²	1.000	ZST	0000000000	0000000000	
	12	6.641-601.0	Cable gland PG21	1.000	ST	0000000000	0000000000	FOR 1.951-801 => 1 QTY.- FOR 1.951-811/-841 => 2 QTY.
	13	6.641-613.0	Cable gland PG13,5	1.000	ST	0000000000	0000000000	
X-X	15	6.635-323.0	2-Phases-Switch	1.000	ST	0000000000	0000000000	
	16	7.306-320.0	Oval head screw M 5x40-A2-70 ISO 7045	1.000	ST	0000000000	0000000000	
	17	6.303-174.0	Screw 6,0X20-ST-A2R	2.000	ST	0000000000	0000000000	
	18	5.019-296.0	Angle	1.000	ST	0000000000	0000000000	
	19	6.601-066.0	Housing	1.000	ST	0000000000	0000000000	
	20	7.303-030.0	Screw M4x8 -St-P2R (In6Rd)	2.000	ST	0000000000	0000000000	
	21		Stockpiling discontinued	1.000	ST	0000000000	0000000000	
	22	6.641-398.0	Rubber bushing 17-19	1.000	ST	0000000000	0000000000	
	23	6.641-612.0	Adaptor	1.000	ST	0000000000	0000000000	
	24	6.362-101.0	O-Ring seal 8 X 2	2.000	ST	0000000000	0000000000	
	25	7.303-033.0	Screw M4x16-ST-A2R (KOMBI-IN6RD)	2.000	ST	0000000000	0000000000	
X	26	7.312-001.0	Washer 4 -200HV-A3E ISO 7089	2.000	ST	0000000000	0000000000	
X-X	27	6.632-355.0	Contactore	1.000	ST	0000000000	0000000000	

50 Electric control box

ET/VT (spare/wear parts)	Pos	Material #	Name	Qty.	Unit	from ser.nr.	up to ser.nr.	Footnote text
	28	7.306-205.0	Screw M4x8 -A2-70 (In6Rd)	2.000	ST	0000000000	0000000000	
	29	5.001-067.0	Plate	1.000	ST	0000000000	0000000000	
	30	6.643-552.0	Strip terminal two-pole	1.000	ZST	0000000000	0000000000	
	31	6.641-370.0	Locknut PG16-PA DIN 46320	1.000	ST	0000000000	0000000000	
	32	6.641-356.0	Cable gland PG16	1.000	ST	0000000000	0000000000	
	33	6.641-639.0	Adaptor PG16/21	1.000	ST	0000000000	0000000000	

Position text: / 1.951-801.0 / -841.0

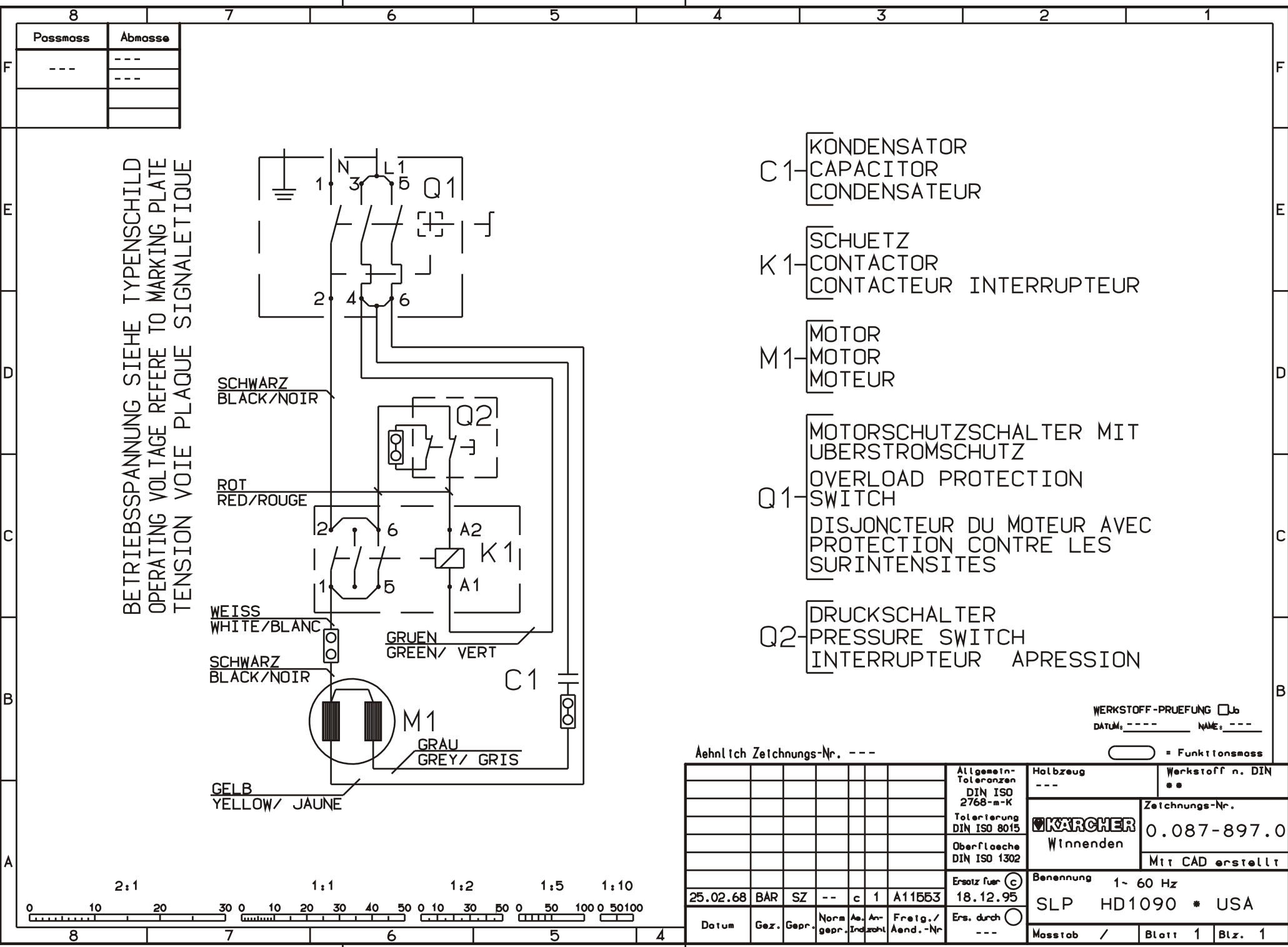

BETRIEBSSPANNUNG SIEHE TYPENSCHILD
 OPERATING VOLTAGE REFERE TO MARKING PLATE
 TENSION VOIE PLAQUE SIGNALETIQUE

- C 1 KONDENSATOR
CAPACITOR
CONDENSATEUR
- K 1 SCHUETZ
CONTACTOR
CONTACTEUR INTERRUPTEUR
- M 1 MOTOR
MOTOR
MOTEUR
- Q 1 MOTORSCHUTZSCHALTER MIT
UBERSTROMSCHUTZ
OVERLOAD PROTECTION
SWITCH
DISJONCTEUR DU MOTEUR AVEC
PROTECTION CONTRE LES
SURINTENSITES
- Q 2 DRUCKSCHALTER
PRESSURE SWITCH
INTERRUPTEUR APRESSION

WERKSTOFF-PRUEFUNG Jb
 DATUM: ---- NAME: ----

= Funktionsmass

Ähnlich Zeichnungs-Nr. ---						Allgemein-Toleranzen DIN ISO 2768-m-K Tolerierung DIN ISO 8015 Oberfläche DIN ISO 1302	Halbzeug ---	Werkstoff n. DIN **
						KÄRCHER Winnenden	Zeichnungs-Nr. 0.087-897.0 Mit CAD erstellt	
Ersatz für <input type="checkbox"/> 25.02.68 BAR SZ -- c 1 A11553 18.12.95						Benennung 1~ 60 Hz SLP HD1090 * USA		
Datum	Gez.	Gepr.	Norm-gepr.	As.-Ind.	Ar.-Anz.	Freig./Änd.-Nr.	Ers. durch <input type="checkbox"/>	Masstab / Blatt 1 Blz. 1

