

English	3
Français	9
Español	15

Register and win!  
[www.kärcher.com](http://www.kärcher.com)

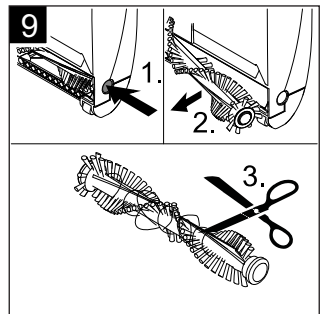

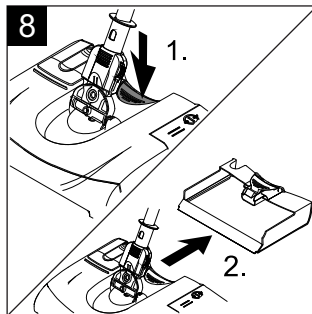
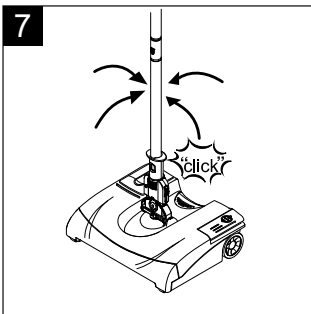
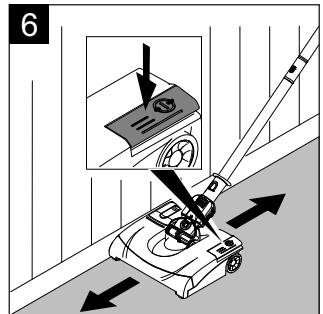
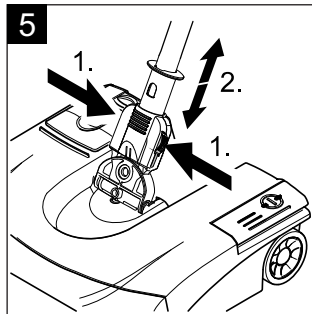
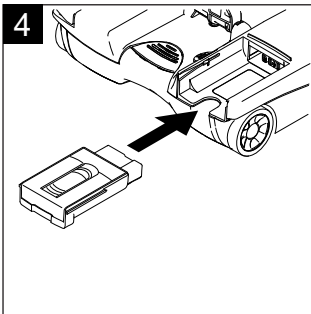
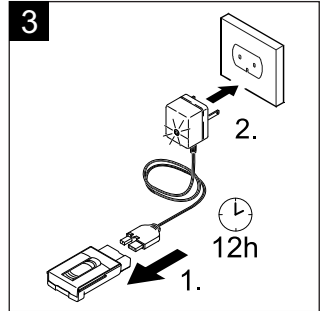
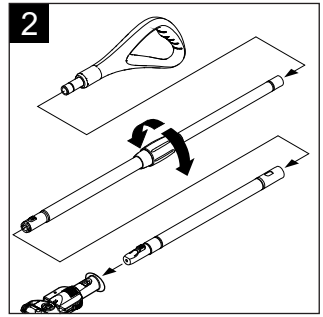
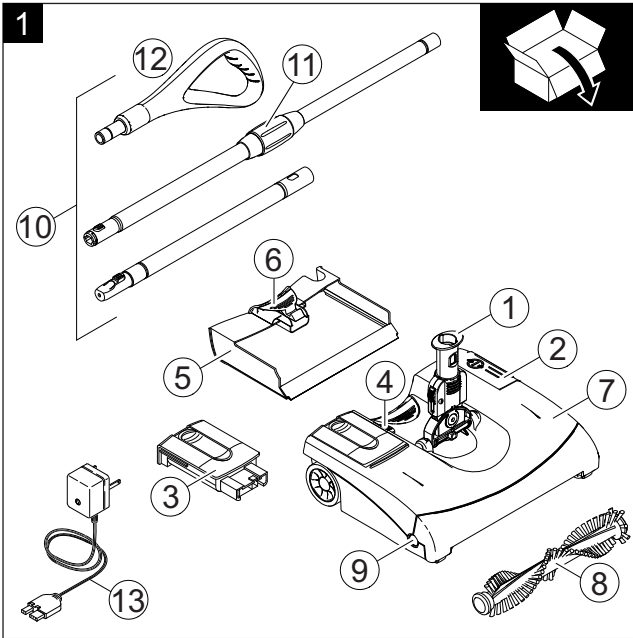

# IMPORTANT SAFETY INSTRUCTIONS

## READ ALL INSTRUCTIONS BEFORE USING THIS MACHINE

- Inform your dealer immediately if there is any shipping damage.
- Completely remove the accessories from the box.
- The sweeper is not suitable to pick up hazardous dusts as asbestos. Please consult your Kärcher branch or your Kärcher dealer with regard to such applications.

When using an electrical machine, basic precautions should always be followed, including the following: This sweeper is intended for commercial use.

- 1 DISCONNECT BATTERY PACK FROM SWEEPER before removing the cover, performing maintenance work, and when not in use.
- 2 ALWAYS CHECK THE POWER CHARGER for damage or signs of any aging before each use.
- 3 DO NOT RUN SWEEPER OVER CORD.
- 4 TURN SWITCH TO OFF before plugging power charger.
- 5 DO NOT UNPLUG BY PULLING CORD. To unplug, grasp plug, not cord.
- 6 DO NOT GRASP PLUG WITH WET HANDS.
- 7 TO AVOID SHOCK, do not expose to rain. Store indoors.
- 8 USE ONLY AS RECOMMENDED BY THIS MANUAL. Use only with recommended attachments.
- 9 KEEP HAIR, CLOTHING, LOOSE JEWELRY, FINGERS and all parts of the body away from openings and moving parts.
- 10 DO NOT BLOCK OR OBSTRUCT OPENINGS. Keep openings free of lint, hair, dust, and anything that restricts air flow.

- 11 DO NOT PICK UP ANYTHING THAT IS BURNING, smoldering, or smoking such as matches, cigarettes, or hot ashes.
- 12 DO NOT USE TO SWEEP IN COMBUSTIBLE EXPLOSIVE MATERIALS, such as coal, grain, and other finely divided combustible material.
- 13 DO NOT USE TO SWEEP IN COMBUSTIBLE, hazardous, toxic, or carcinogenic materials, including gasoline, diesel fuel, acetone, paint thinner, heating oils, undiluted acids and solvents, pesticide, and asbestos.
- 14 DO NOT ALLOW SWEEPER TO BE USED AS A TOY. Keep children away from sweeper.
- 15 DO NOT LEAVE UNATTENDED while sweeper is running.
- 16 DO NOT USE IF SWEEPER IS IN POOR CONDITION. If the sweeper has been dropped, damaged, exposed to weather, or dropped into water; have it checked by an authorized service.
- 17 ALWAYS USE EYE PROTECTION when operating sweeper.
- 18 USE EXTRA CAUTION when operating on stairs.
- 19 STAY ALERT! Do not use sweeper when you are tired or under the influence of drugs, alcohol or medication.

## SAVE THESE INSTRUCTIONS



Please read and comply with these original instructions prior to the initial operation of your appliance and store them for later use or subsequent owners.

## Contents

Proper use . . . . .	EN . . . 1
Environmental protection . .	EN . . . 1
Symbols in the operating instructions . . . . .	EN . . . 1
Safety instructions . . . . .	EN . . . 2
Start up . . . . .	EN . . . 2
Operation . . . . .	EN . . . 3
Transport . . . . .	EN . . . 4
Storage . . . . .	EN . . . 4
Maintenance and care . . .	EN . . . 4
Service . . . . .	EN . . . 4
Technical specifications . . .	EN . . . 5

## Proper use

- This appliance is suited for the commercial use, e.g. in hotels, schools, hospitals, factories, shops, offices, and rental companies along with the authorised accessories and spare parts.
- This appliance has restrictive use for carpets with high flounce.
- The appliance is **not** suitable for wet floors.
- The appliance is **not** suitable for washing concrete, gravel, etc.

Any use extending beyond this is not considered as proper use. The manufacturer is not liable for any losses resulting from this; the user alone bears the risk for this.

## Environmental protection

	The packaging material can be recycled. Please do not throw the packaging material into household waste; please send it for recycling.
	Old appliances contain valuable materials that can be recycled; these should be sent for recycling. Batteries and accumulators contain substances that must not enter the environment. Please dispose off old devices, batteries and rechargeable batteries through suitable waste collection systems.

Remove the integrated battery prior to disposing of the appliance and dispose of properly!

**Do not open the battery**, as there is a risk of an electrical short; also, irritating or caustic vapors can escape.

### Notes about the ingredients (REACH)

You will find current information about the ingredients at:

[www.kaercher.com/REACH](http://www.kaercher.com/REACH)

## Symbols in the operating instructions

### **Danger**

*Immediate danger that can cause severe injury or even death.*

### **Warning**

*Possible hazardous situation that could lead to severe injury or even death.*

### **Caution**

*Possible hazardous situation that could lead to mild injury to persons or damage to property.*

## Safety instructions

In addition to the information contained in the operating instructions, all statutory safety and accident prevention regulations must be observed.

### **⚠ Risk of injury**

- *The appliance contains rotary brush roller; please never touch them with the fingers or any other tool when the appliance is in operation!*
- *Remove the batteries before starting any maintenance jobs or repairs to the machine!*

### **⚠ Tips about rechargeable battery and charger**

- You may recharge the battery using only the original charger provided with the appliance or a charger approved by KÄRCHER.
- Check charger, mains cable and battery pack for damages before every use. Do not use damaged devices and get the damaged parts repaired only by experts.
- Do not use the charger if dirty or wet.
- The mains voltage must match the voltage mentioned on the type plate of the charger.
- Do not operate the charger in explosive environment.
- Ensure that no metal pieces reach the contacts of the adapter, else there will be a short circuit.
- Use the charger only to charge approved battery packs.
- Insert only clean and dry battery packs on the adapter of the charger.
- Do not charge batteries (primary cells); risk of explosion.
- Do not charge damaged battery packs. Replace damaged battery packs.
- Do not store battery packs along with metal objects; risk of short circuit.
- Do not dispose off battery packs by throwing them into fire or into household garbage.

- Avoid contact with liquids oozing out of defective battery packs. Rinse thoroughly if you accidentally come in contact with the fluid. Also consult a doctor if the fluid comes in contact with your eyes.

## Symbols on the machine



Protect the charger against moisture; store it dry. The appliance is suitable for use only in rooms; do not expose the appliance to rain.

## Start up

### Description of the Appliance

When unpacking the product, make sure that no accessories are missing and that none of the package contents have been damaged. If you detect any transport damages please contact your dealer.

**Note:** Please refer to page 2 for figures of the appliance and the operation.

- 1 Cardan joint with lock
- 2 ON/OFF foot switch
- 3 Rechargeable battery, detachable
- 4 Unlocking button, battery
- 5 Dirt container, detachable
- 6 Unlocking mechanism for dirt container
- 7 Casing
- 8 Brush roller, changeable
- 9 Unlocking button for brush roller
- 10 Telescopic strut, adjustable height
- 11 Turning handle for height adjustment
- 12 Handle
- 13 Charger with charging status display and charging cable

## Installing the telescopic handle and the handle and adjusting the height

see *Figure 2*

The telescopic strut consists of 3 parts. While assembling it, make sure that the parts lock into each other.

- Insert the handle on the longer strut with turning handle.
- Insert together the longer and shorter struts; while assembling it, press the locking button.
- Insert the entire strut with the locking button into the joint on the appliance.
- Loosen the handle and pull out the strut to the desired working height; turn the handle to the correct position and tighten using the turning handle.

### Charge the battery

see *Figure 3*

The battery is not charged at the time of delivery. Charge it before commissioning the appliance and then as and when required.

**Note:** The battery can be charged only when it is removed out of the appliance.

- Connect the battery to the charger using the charging cable or rather insert the battery in the charger.
- Insert the charger delivered with the appliance into a proper socket.

The charger display glows red. The battery is being charged.

### Charging time for empty battery

Charger	NiCd
BC 1/0.1	12 h

**Note:** If the charging time is exceeded, the charger shifts to retention charging. The charger display continues to glow red.

### Insert the battery

see *Figure 4*

- Insert the battery into the intake and lock it.

## Operation

### Lock/unlock telescope strut on the side

see *Figure 5*

The Cardan joint can be locked to clean high-fiber carpets to prevent the telescope strut from moving from side to side.

- Lock/unlock telescope strut on the side:
  - Activate the lock, then move it down and lock it in.
  - Unlock telescopic strut:
    - Activate the lock, then move it up and lock it in.

### Starting the work

see *Figure 6*

- Switch on the appliance; press the on/off foot switch to do so.
- Move the appliance forward and backward to clean it.
- Use the right side (battery side) to clean the appliance close to the edges.

### Interrupting the work

see *Figure 7*

- Switch off the appliance; press the on/off foot switch to do so.
- To ensure that the telescopic strut stands safely during breaks in operation, hold it vertically; there is a stopper that holds it in position.

### Finishing your work

- Switch off the appliance when finished.
- Empty dirt container after each cleaning.
- Press the unlocking button of the battery and remove the battery.
- Charge the battery.

### Emptying the dirt container

see *Figure 8*

- Unlock the dirt container and remove it.
- Empty the dirt container.
- Insert and lock into place the dirt container.

## Storing the appliance

- The appliance can be hung with the handle; turn the handle if required (see chapter "Install Telescopic strut and handle and adjust the height").

## Transport

### Caution

*Risk of injury and damage! Observe the weight of the appliance when you transport it.*

When transporting in vehicles, secure the appliance according to the guidelines from slipping and tipping over.

## Storage

### Caution

*Risk of injury and damage! Note the weight of the appliance in case of storage.*

This appliance must only be stored in interior rooms.

## Maintenance and care

### Caution

*Remove the battery prior to any care and maintenance work.*

### Cleaning the device

- Wipe the appliance using a damp cloth. Do not use any aggressive agents, such as cleaning powder.

### Change/ clean the brush roller

see *Figure 9*

- Press the unlocking button and remove the brush roller.
- Remove wound up hair using a knife or scissors by moving the knife along the defined cutting edge of the brush roller. Remove loosened hair from the brush roller.
- Insert the cleaned or new brush roller and ensure that it sits properly.

## Service

### Warranty

The warranty terms published by the relevant sales company are applicable in each country. We will repair potential failures of your appliance within the warranty period free of charge, provided that such failure is caused by faulty material or defects in manufacturing. In the event of a warranty claim please contact your dealer or the nearest authorized Customer Service centre. Please submit the proof of purchase.

### Troubleshooting

#### Caution

*Turn the appliance off and remove the accumulator prior to performing any tasks on the appliance.*

#### Charger display does not glow

- Check connection from charger to battery
- Check power supply of the socket.

#### Appliance does not clean properly

- Clean or replace the brush rollers (refer chapter "Replace/ clean brush roller").
- Charge the battery (refer chapter "Charging the battery").

#### Dirt is being thrown out of the appliance

- Empty the full dirt container (refer chapter "Empty dirt container").

### Special accessories

Description	Order No.
Quick Charger BC 1/1.8	6.654-197.0
Spare battery NiCd	4.654-259.0
Brush rollers, soft, red	4.762-401.0

### Customer Service

Our KÄRCHER branch will be pleased to help you further in the case of questions or faults. See address on the reverse.

## Technical specifications

Rechargeable battery type		<b>EB 30/1</b>
Max. operating time when battery is fully charged (depends on the flooring)	min	45
Working voltage of the battery	V	7.2
Output voltage of the charger	V	8.6
Charging current	A	0.1
Rated power	W	25
Mains voltage of the charger	V	120
	Hz	1~ 60
Sound pressure level (EN 60704-2-1)	dB(A)	56
Typical operating weight	lbs (kg)	6.2 (2.8)



