

Spare parts list
(5.971-026.0) Spare parts list CV 38/2, CV 48/2

Table of contents

Spare parts list CV 38/2, CV 48/2 (5.971-026.0)	6
10 Top part (0.165-303.0)	7
11 Individual parts (0.164-998.0).....	8
12 Appliance top part (0.165-304.0)	10
20 Brush-head (0.165-305.0).....	12
21 Brush-head (0.165-306.0)	13
22 Brush-head (0.165-307.0)	16
30 Vacuum motor (0.165-308.0)	19
40 Accessories (0.165-205.0).....	21

Spare parts list CV 38/2, CV 48/2 (5.971-026.0)

Pos	Material #	Name	Qty.	Unit
10	0.165-303.0	Top part	1.000	ST
20	0.165-305.0	Brush-head	1.000	ST
30	0.165-308.0	Vacuum motor	1.000	ST
40	0.165-205.0	Accessories	1.000	ST

10 Top part (0.165-303.0)

Pos	Material #	Name	Qty.	Unit
11	0.164-998.0	Individual parts	1.000	ST
12	0.165-304.0	Appliance top part	1.000	ST

11 Individual parts (0.164-998.0)

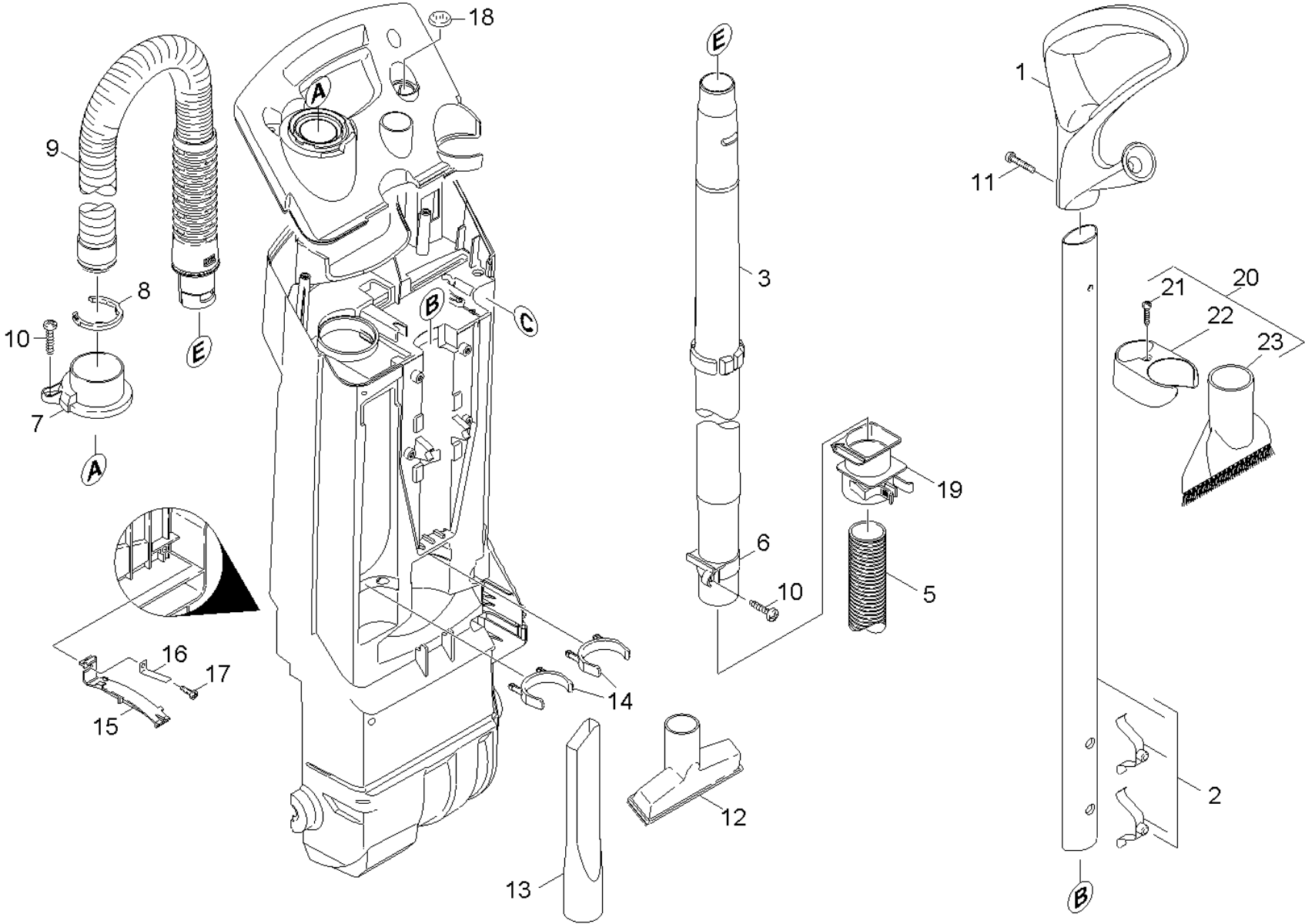

11 Individual parts (0.164-998.0)

ET/VT (spare/wear parts)	Pos	Material #	Name	Qty.	Unit	from ser.nr.	up to ser.nr.
	1	5.321-713.0	Handhold	1.000	ST	0000000000	0000000000
	2	4.128-001.0	Handle complete only for replacement	1.000	ST	0000000000	0000000000
X-X	3	5.129-046.0	Suction tube	1.000	ST	0000000000	0000000000
X-X	5	6.391-115.0	Suction hose DN32	1.000	ST	0000000000	0000000000
X	6	5.570-075.0	Ring suction tube	1.000	ST	0000000000	0000000000
X-X	7	5.032-540.0	Hosebarb	1.000	ST	0000000000	0000000000
X-X	8	5.031-011.0	Locking ring	1.000	ST	0000000000	0000000000
X-X	9	6.391-934.0	Suction hose DN32	1.000	ST	0000000000	0000000000
X-X	10	7.303-108.0	Screw 5x20 -10.9-R2R (In6Rd)	2.000	ST	0000000000	0000000000
	11	7.303-278.0	Screw 5x45 -A2-70 (In6Rd)	1.000	ST	0000000000	0000000000
X-X	12	6.900-233.0	Upholstery nozzle DN35	1.000	ST	0000000000	0000000000
X-X	13	6.906-240.0	Crevice nozzle DN35	1.000	ST	0000000000	0000000000
X	14	5.041-111.0	Clip accessories	2.000	ST	0000000000	0000000000
	15	5.042-836.0	Holder filter	1.000	ST	0000000000	0000000000
	16	5.332-339.0	Spring	1.000	ST	0000000000	0000000000
	17	7.303-106.0	Screw 4x12 -10.9-R2R (IN6RD)	1.000	ST	0000000000	0000000000
	18	5.031-521.0	Lens	1.000	ST	0000000000	0000000000
X-X	19	5.407-135.0	Sleeve suction tube	1.000	ST	0000000000	0000000000
	20	4.262-015.0	Accessories kit clamp	1.000	ST		
X-X	21	7.303-212.0	Screw 5x20 -A2-70 (In6Rd)	1.000	ST		
	22	5.332-980.0	Clamp	1.000	ST		
X-X	23	6.903-862.0	Suction brush DN35	1.000	ST		

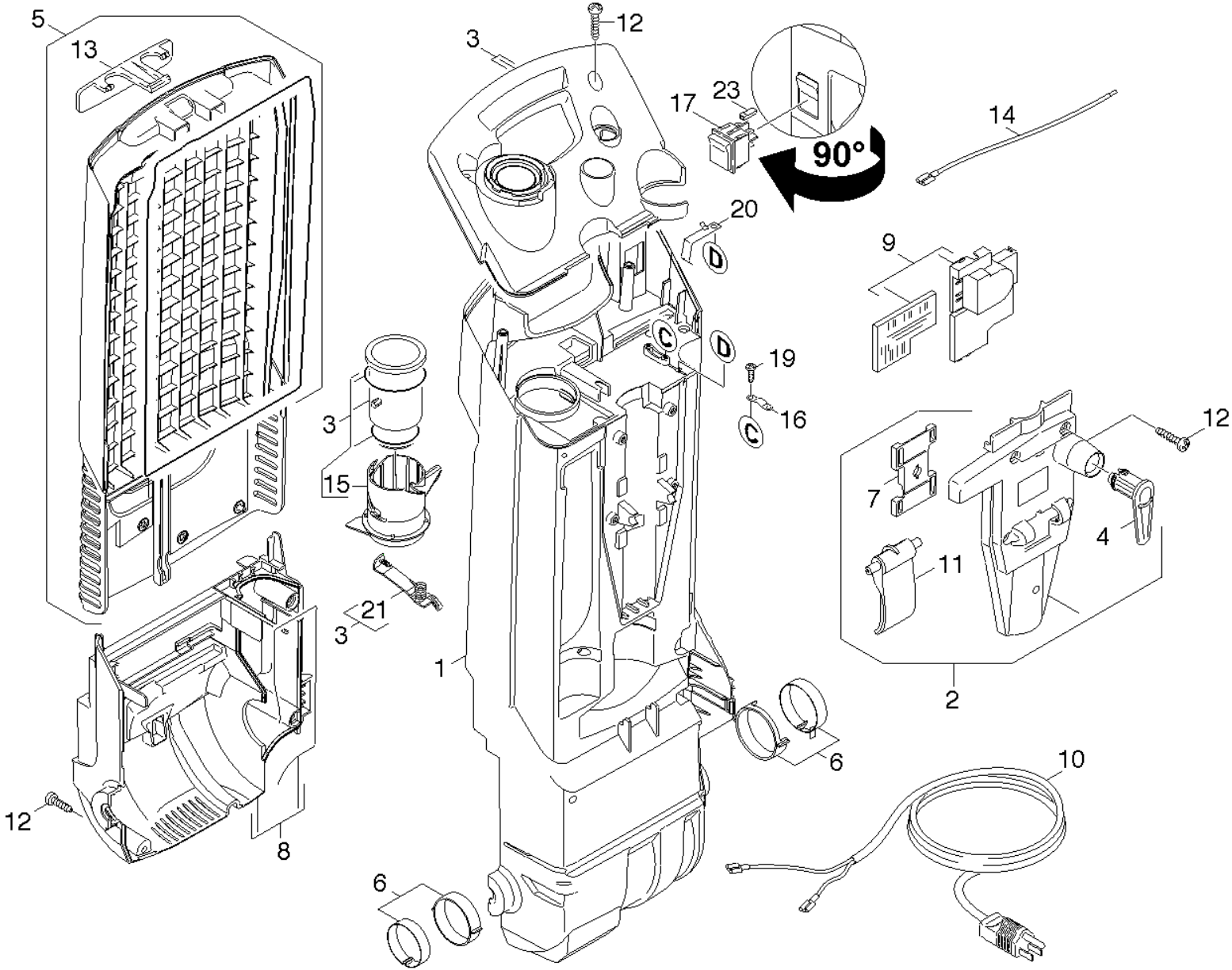

12 Appliance top part (0.165-304.0)

ET/VT (spare/wear parts)	Pos	Material #	Name	Qty.	Unit	from ser.nr.	up to ser.nr.
	1	5.060-991.0	Housing	1.000	ST	0000000000	0000000000
	2	4.032-003.0	Covering cap complete only for replaceme	1.000	ST	0000000000	0000000000
X-X	3	4.032-004.0	Covering cap electric	1.000	ST	0000000000	0000000000
X-X	4	5.044-661.0	Catch for cable	1.000	ST	0000000000	0000000000
	5	4.064-016.0	Cover complete	1.000	ST	0000000000	0000000000
X-X	6	2.889-076.0	Set bearing shells	1.000	ST		
	7	5.032-448.0	CLAMP	1.000	ST	0000000000	0000000000
	8	4.053-224.0	Covering cap motor complete nur fuer Ers	1.000	ST	0000000000	0000000000
	9	4.682-001.0	Circuit board only for replacement CV30/	1.000	ST	0000000000	0000000000
X-X	10	4.649-026.0	Power cable nur fuer Ersatz	1.000	ST		
	11	5.481-345.0	Clamp lever	1.000	ST	0000000000	0000000000
X-X	12	7.303-108.0	Screw 5x20 -10.9-R2R (In6Rd)	9.000	ST	0000000000	0000000000
X	13	5.075-030.0	Closure cover	1.000	ST	0000000000	0000000000
	14	4.839-411.0	Electrical small parts CV 38/2, CV 48/2	1.000	ST	0000000000	0000000000
	15	5.481-352.0	OPERATING LEVER	1.000	ST		
	16	6.903-241.0	Clamp clip	1.000	ST	0000000000	0000000000
	17	6.630-156.0	Rocker switch black	1.000	ST	0000000000	0000000000
	19	6.303-318.0	Screw 3,5x12-10.9-R2R (IN6RD)	2.000	ST	0000000000	0000000000
	20	5.034-689.0	Spring earthing	1.000	ST	0000000000	0000000000
	21	4.332-008.0	Spring connection piece completely	1.000	ST	0000000000	0000000000
	23	6.647-748.0	Insulation sheath	2.000	ST		

20 Brush-head (0.165-305.0)

Pos	Material #	Name	Qty.	Unit	var. information
21	0.165-306.0	Brush-head	1.000	ST	CV 38/2
22	0.165-307.0	Brush-head	1.000	ST	CV 48/2

22 Brush-head (0.165-307.0)

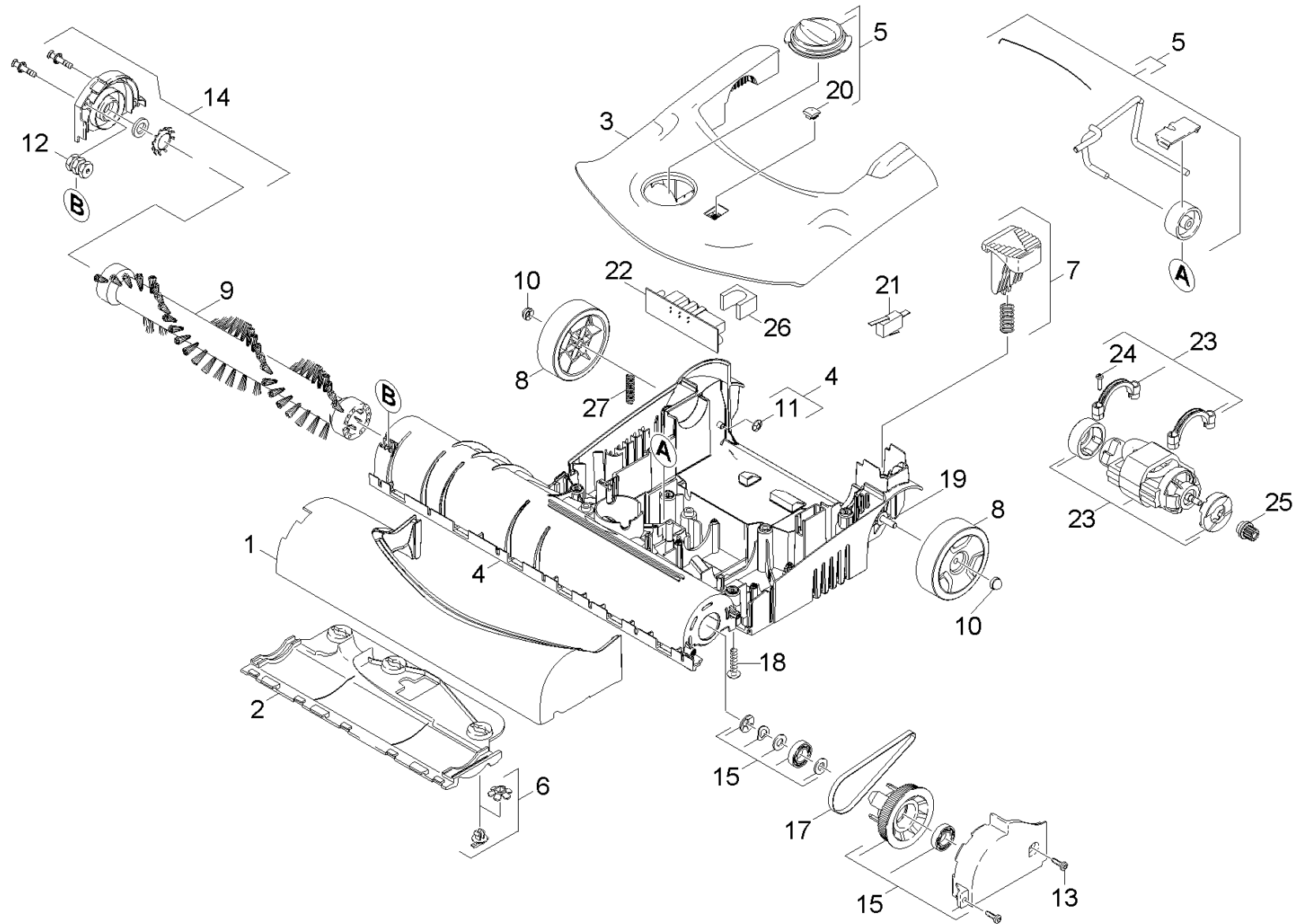

22 Brush-head (0.165-307.0)

ET/VT (spare/wear parts)	Pos	Material #	Name	Qty.	Unit	from ser.nr.	up to ser.nr.
	1	5.033-457.0	Bumper	1.000	ST	0000000000	0000000000
X	2	5.033-456.0	Sliding bottom	1.000	ST	0000000000	0000000000
	3	4.062-008.0	Housing top part complete	1.000	ST	0000000000	0000000000
	4	4.062-009.0	Housing complete	1.000	ST	0000000000	0000000000
X-X	5	4.515-311.0	Adjusting wheel complete	1.000	ST	0000000000	0000000000
X-X	6	2.884-273.0	Closure parts set only for replacement	1.000	ST	0000000000	0000000000
X-X	7	4.481-000.0	Foot pedal complete only for replacement	1.000	ST	0000000000	0000000000
X	8	5.515-374.0	Wheel	2.000	ST	0000000000	0000000000
X-X	9	4.762-489.0	Roller brush black	1.000	ST	0000000000	0000000000
X-X	10	6.343-187.0	Lock washer	2.000	ST	0000000000	0000000000
X-X	11	6.343-119.0	Lock washer	2.000	ST	0000000000	0000000000
X-X	12	5.401-288.0	Screw connector part	2.000	ST	0000000000	0000000000
	13	7.303-106.0	Screw 4x12 -10.9-R2R (IN6RD)	2.000	ST	0000000000	0000000000
X-X	14	4.063-892.0	Covering cap complete brush Aluminiumdru	1.000	ST	0000000000	0000000000
X-X	15	4.063-774.0	Covering cap complete belt	1.000	ST	0000000000	0000000000
X-X	17	6.348-460.0	Toothed belt	1.000	ST	0000000000	0000000000
	18	6.303-200.0	Screw 5x25-IN6RD	8.000	ST	0000000000	0000000000
X-X	19	9.412-178.0	Axle	1.000	ST		
	20	5.033-452.0	Lens	1.000	ST		
X-X	21	6.630-135.0	Micro switch	1.000	ST		
	22	6.682-290.0	Printed circuit board 115 V	1.000	ST		
X-X	23	4.613-003.0	Motor complete	1.000	ST		
	24	7.303-096.0	Screw 4x22 -ST-10.9-R2R (IN6RD)	4.000	ST		
X-X	25	5.033-459.0	Pinion	1.000	ST		
X	26	6.286-573.0	Protecting cap	1.000	ST		

22 Brush-head (0.165-307.0)

ET/VT (spare/wear parts)	Pos	Material #	Name	Qty.	Unit	from ser.nr.	up to ser.nr.
	27	5.332-082.0	Helical spring	1.000	ST		

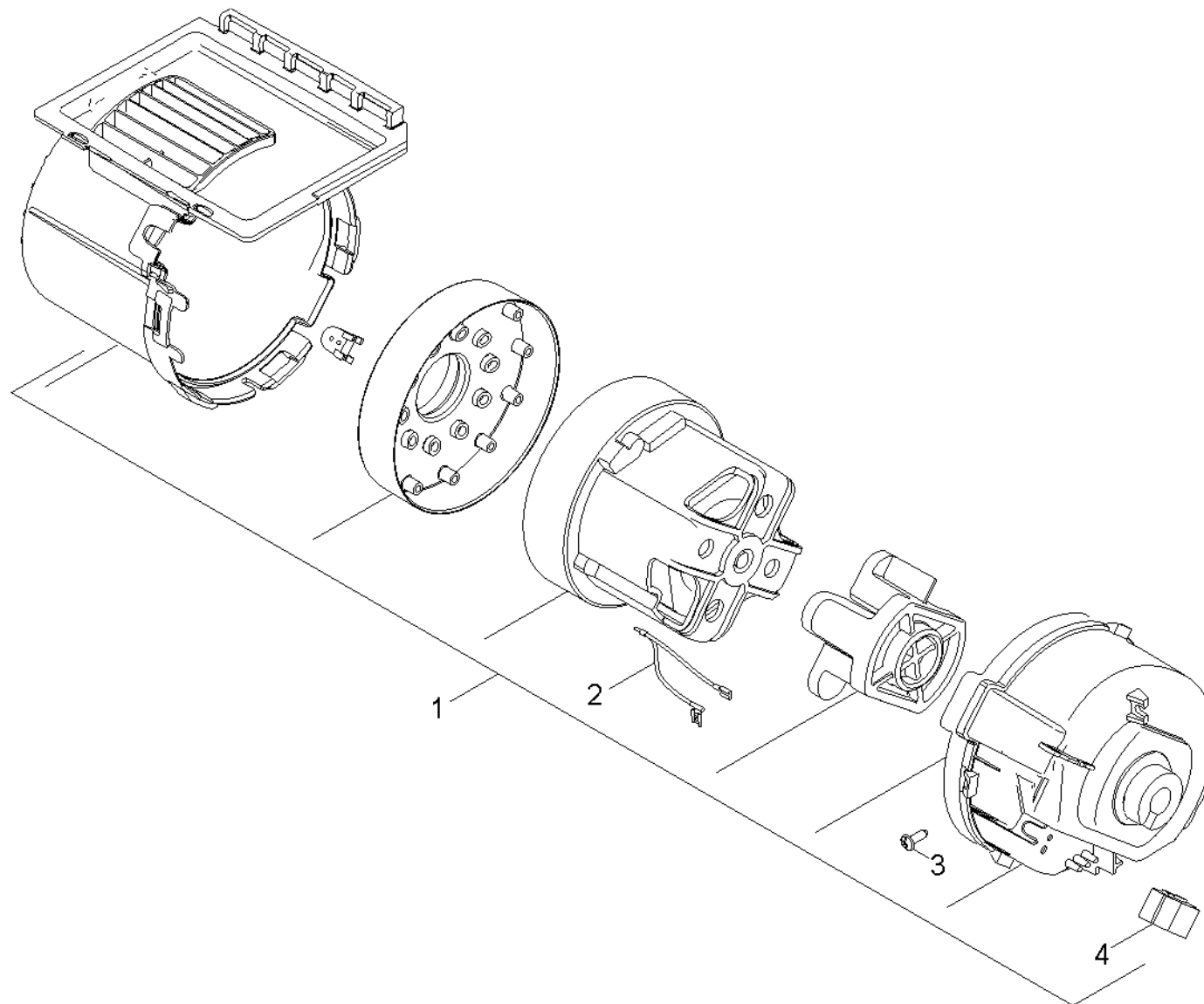

30 Vacuum motor (0.165-308.0)

ET/VT (spare/wear parts)	Pos	Material #	Name	Qty.	Unit
X-X	1	4.060-814.0	Motor housing complete	1.000	ST
	2	6.649-765.0	Cable vacuum motor	2.000	ST
	3	7.303-106.0	Screw 4x12 -10.9-R2R (IN6RD)	4.000	ST
	4	6.643-551.0	Strip terminal	1.000	ST

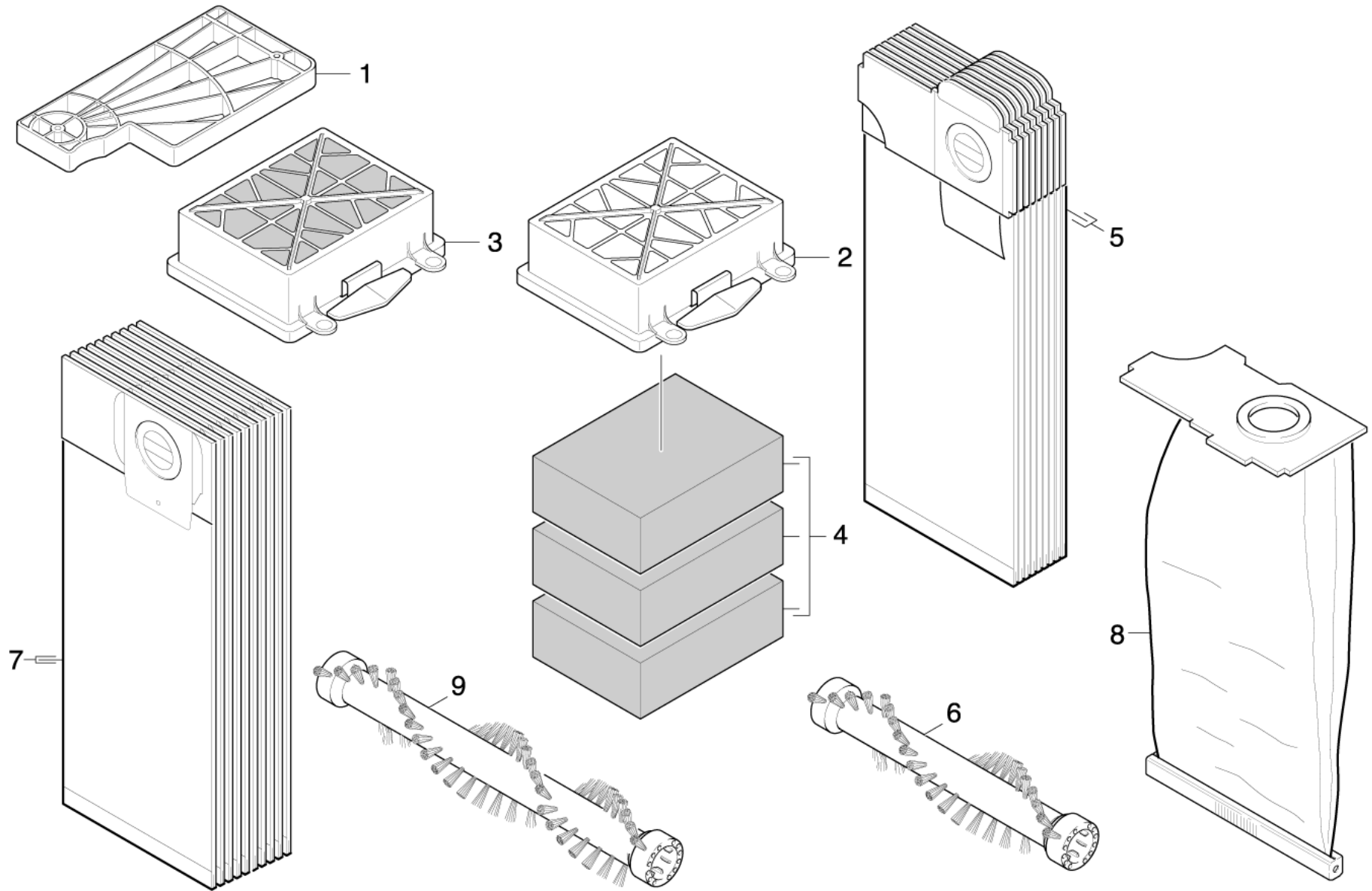

40 Accessories (0.165-205.0)

ET/VT (spare/wear parts)	Pos	Material #	Name	Qty.	Unit	from ser.nr.	up to ser.nr.	var. information	Footnote text
X-X	1	5.731-611.0	Filter motor protecting	1.000	ST	0000000000	0000000000		
X-X	2	5.731-614.0	Filter frame grey	1.000	ST	0000000000	0000000000		
X-X	3	6.414-760.0	Filter packaged HEPA	1.000	ST	0000000000	0000000000		
X-X	4	4.414-015.0	Filter sponge Kärcher 3St.	1.000	ST	0000000000	0000000000		
X-X	5	6.904-294.0	FILTER BAGS 10 PC	1.000	ST	0000000000	0000000000		
X-X	6	6.906-644.0	Roller brush red	1.000	ST	0000000000	0000000000	CV 38/2	RED
X-X	6	4.762-487.0	Roller brush antistatic	1.000	ST			CV 38/2	ANTISTATIC
X-X	7	6.904-305.0	Filter bag fleece 10 Stk.	1.000	ST	0000000000	0000000000		
X-X	8	6.904-301.0	Filter bag cloth	1.000	ST	0000000000	0000000000		
X-X	9	4.762-489.0	Roller brush black	1.000	ST			CV 48/2	BLACK
X-X	9	4.762-488.0	Roller brush red	1.000	ST			CV 48/2	RED