

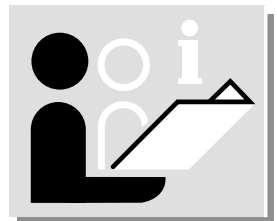

BR/BD 530 BAT
BR/BD 530 XL BAT
BR/BD 530 BAT Package
BR/BD 530 XL BAT Package
BR/BD 530 F BAT Package
BR/BD 530 XL F BAT Package

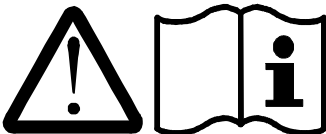

Deutsch



Türkçe



English



Русский



Français



Magyar



Italiano



Česky



Nederlands



Slovensky



Español



Polski



Português



Românește



Dansk



Slovensko



Norsk



Hrvatski



Svenska



Srpski



Suomi



Български



Ελληνικά



Safety notes

Before using the unit, please read and comply with the operating instructions and the enclosed brochure "Safety instructions for brush cleaning units and spray extraction units", No. 5.956-251.

It is permitted to operate the unit on surfaces with no more than a 2 % incline.

The unit must not be operated until the tanks and all covers have been closed.

Symbols

The following symbols are used in these operating instructions:



Danger!

Indicates imminent danger. Non-compliance with this warning may result in death or serious injury.



Caution!

Indicates a potentially dangerous situation. Non-compliance with this warning may result in slight injury or damage to property.



Information:

Indicates application tips and important product information.

Function

BR/BD 530 BAT package or BR/BD 530 XL-BAT is used for wet-cleaning of level floors. It can easily be adapted to the particular cleaning task by adjustment of the water flow rate and the dirty water pick-up.

An operating width of up to 460 mm or 530 mm (XL-model) and an 40 l fresh-water tank and dirty-water tank enable effective cleaning over a prolonged period.

The batteries can be charged with a battery charger connected to a mains socket.

A battery charger is already installed in the BR/BD 530 BAT Package and BR/BD 530 XL BAT Package

Appropriate use

Use this unit exclusively in accordance with the information in these operating instructions.

- The unit may be used for cleaning non-moisture-sensitive smooth floors only.
- The unit is not suitable for cleaning frozen floors (e.g. in cold-storage depots).
- The unit may be fitted with original accessories and spare parts only.

Protection of the environment

Please dispose of packaging in an environmentally friendly manner



The packaging materials can be recycled. Please do not dispose of the packaging with domestic refuse but have it recycled.

Please dispose of old units in an environmentally friendly manner



Old units contain valuable recyclable materials which should be reclaimed. Batteries, oil and similar substances must not pollute the environment. Please therefore dispose of old units via suitable collection systems.

Operating and function controls

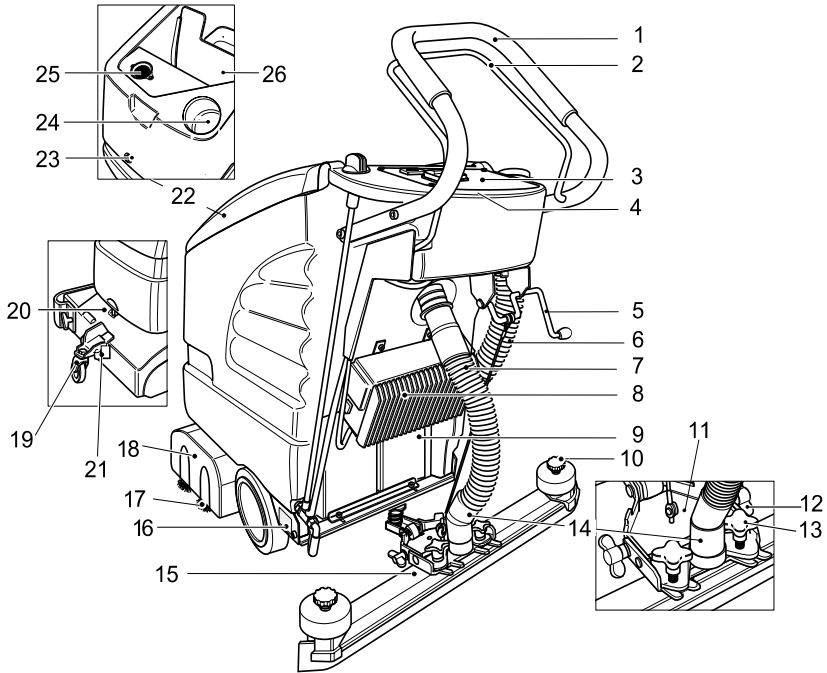

- | | |
|---|---|
| 1 Push handle | 16 Rating plate |
| 2 Trigger lever for brush mode | 17 Roller brushes (BR model)
Disc brushes (BD model)* |
| 3 Control console | 18 Cleaning head |
| 4 Electronics module and fuses
(under the control console) | 19 Running gear |
| 5 Lever for raising/lowering the suction
bar | 20 Handle |
| 6 Drainage hose for dirty water | 21 Locking device |
| 7 Suction hose | 22 Cover |
| 8 Battery charger (package model) | 23 Screw for locking the container;
in the container: batteries* |
| 9 Battery (package model) | Under the cover: |
| 10 Star knobs for replacing the squeegee
blades | 24 Fresh-water filler inlet |
| 11 Suction-bar suspension device | 25 Fluff strainer |
| 12 Wing nut for inclining the suction bar | 26 Dirty-water tank |
| 13 Star knob for attachment and angular
positioning of the suction bar | |
| 14 Suction hose–suction motor connection | * not illustrated |
| 15 Suction bar** | ** not supplied with the appliance |

Instrument panel

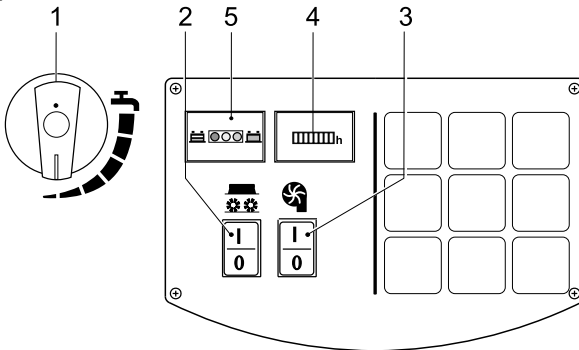

- | | |
|---|--|
| <p>1 Detergent metering</p> <p>2 Brush mode switch</p> <p>3 Suction motor switch</p> <p>4 Hours counter (package version)</p> | <p>5 Battery indicator display</p> <p>green: Batteries fully charged</p> <p>yellow: Batteries partially discharged</p> <p>red,
flashing: Batteries exhausted</p> <p>red,
continuous: Deep-discharge protection</p> |
|---|--|

Before switching on the unit

Unloading the unit

- Attach push handle with the 4 supplied screws and fit the caps.
- Place the long, lateral planks from the packaging on the pallet and form a ramp.
- Secure the planks with nails.
- Support the ramp by placing the shorter planks underneath.
- Remove the wooden laths.
- Raise the cleaning head and remove the cardboard packaging.
- The unit can now be moved down the ramp.

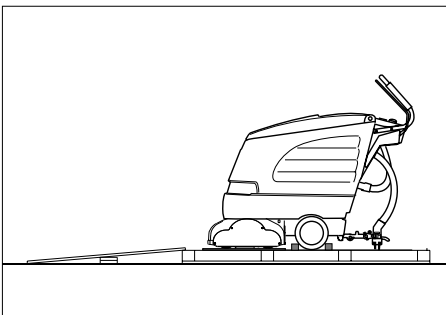

Attaching the suction bar

- Insert the suction bar into the suction-bar suspension device, ensuring that the profiled sheet is situated over the suspension device.
- Tighten the star knobs.

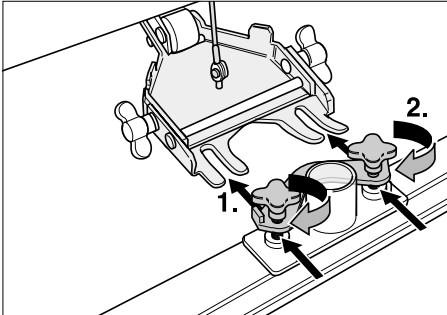

- Attach the suction hose.

Attaching the brushes

BD 530 BAT Package or BD 530 XL BAT Package

Before switching on the unit, the disc brushes must be attached (see “Maintenance procedures”).

Batteries

When handling batteries, comply with the following warning symbols:

 *Comply with the information on the battery, in the operating instructions and in the vehicle operating instructions.*

 *Wear eye protection*

 *Keep children away from acid and batteries*

 *Danger of explosion*

 *No naked flames, sparks or naked lights and no smoking*

 *Risk of chemical burns*

 *First Aid*

 *Warning*

 *Disposal*

Please dispose of battery or rechargeable battery in an environmentally friendly manner

 Batteries and rechargeable batteries contain substances which must not pollute the environment. Please therefore dispose of batteries via suitable collection systems.

 **Danger of explosion!**
Do not place any tools or similar objects on the battery, i.e. on the terminals and intercell connectors.

 **Risk of injury!**
Do not bring any wounds into contact with lead; after working with batteries, always wash hands.

Inserting and connecting batteries

- Loosen the screw and open the container.
- Insert the batteries into the container flush with the cleaning head.
- Grease the terminals and connect to the enclosed cables.

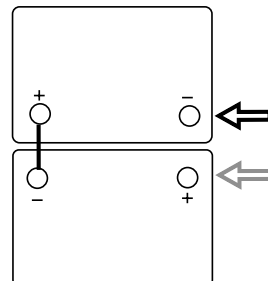

**Caution!**

Ensure that the polarity is correct!

- Clamp the supplied connection cable to the remaining free battery terminals (+) and (-).
- Close the container and tighten the screw.

**Caution!**

Before switching on the unit, charge the batteries!

Charging the batteries**Danger of explosion!**

Lead-acid batteries may only be charged when the container is open.

**Danger of electric shock!**

Note power supply system and fusing – see “Battery charger”.

Never use the battery charger in rain, in high atmospheric humidity or in damp rooms!

**Information:**

The unit features deep-discharge protection, i.e. if the still permitted minimum capacity value is reached, the brush motors and the turbine are switched off. In this case the battery charge status display on the control console illuminates red.

The battery charging process lasts on average 10–15 hours. The recommended battery chargers (which correspond to the utilised batteries) are electronically controlled and end the charging process automatically.

All functions of the unit are automatically interrupted during the charging process.

- Push the battery charger directly onto the charging station.

Charging process for BR/BD 530 BAT Package and for BR/BD 530 XL BAT Package

- Insert the connection cable plug into the socket.

Charging process BR/BD 530 BAT

- Disconnect the suction hose from the suction bar.
- Loosen the screw and open the container.
- Remove the battery connector and connect to the charger cable.
- Switch on battery charger.

Non-maintenance-free batteries

- One hour before the end of the charging process, add distilled water, ensuring that the acid level is correct. Batteries are identified accordingly.

**Risk of injury!**

If a discharged battery is refilled with water, acid may escape!

When handling battery acid, wear protective goggles and follow the instructions to prevent injury and damage to clothing.

Immediately wash off any acid splashes on the skin or clothing using plenty of water.

**Caution!**

Use only chemically pure battery acid (in compliance with VDE 0510), concentration 1.28 kg/l.

Refill the batteries with distilled or demineralised water only (VDE 0510).

Do not use additives (so-called enhancing agents), otherwise any warranty will be invalidated.

Recommended batteries

Manufacturer	Description
Kärcher order no.	
DETA	12 V GIS 80
6.654-097	low-maintenance Capacity: 80 Ah Voltage: 12 V
DETA	12 V GIV 75 DT
6.654-093	maintenance-free Capacity: 75 Ah Voltage: 12 V
SONNEN-SCHEIN	12 V / 70 Ah
	maintenance-free Capacity: 70 Ah Voltage: 12 V

Recommended battery chargers

Manufacturer	Description
KÄRCHER	for maintenance-free batteries 6.654-102
KÄRCHER	for low-maintenance batteries 6.654-067

Batteries and battery chargers are available from specialist outlets.

Caution!
Use only maintenance-free batteries with package battery chargers.

Operation

Caution!
Before reversing, raise the suction bar.

Information:
The unit is designed with the brush head projecting from the right side, enabling the operator to clean up to the very edge.

Adding detergent

Caution!
Use the recommended detergents only. If other detergents are used, the operator increases the risk of malfunctions and accidents.
Detergents must not contain solvents, hydrochloric acid or hydrofluoric acid.

Information:
Do not use detergents which foam vigorously.

- Open the cover.
- Fill with fresh water (maximum 60 °C).
- Add detergent.
Comply with the metering information.

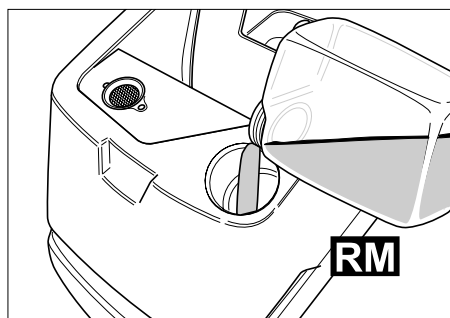

Recommended detergents

Application:	Detergent
Maintenance cleaning (also for alkaline-sensitive floors)	RM 745 RM 746
Cleaning greasy dirt deposits	RM 69 ES ASF RM 69 ASF
Basic cleaning (stripping) alkaline- resistant hard floor coverings	RM 752
Basic cleaning stripping linoleum	RM 754
Sanitary cleaner	RM 25 ASF
Disinfectant cleaner	RM 732

Detergents are available from specialist outlets.

Driving

- Close the cover.
- Switch on the brush mode switch and suction motor.

i Information:
If the brush motor does not start when switched on, unload the brush motor by pulling back the unit.

Running gear

Down: Transportation

Up: Cleaning

- Raise the unit slightly with the handle.
- Pull out the locking device.
- Swivel the running gear into the desired position.
- Engage the locking device.

Driving to the place of work

- Swivel down the running gear and lock.
- Push the unit to the place of work.

Cleaning

- Swivel up the running gear and lock.
- Clean the unit.

Adjust the propulsion speed

(only BD 530 BAT or BD 530 XL BAT)

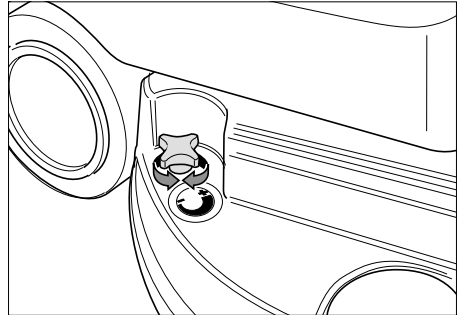

- Throttle speed:
rotate knob towards -.
- Increase speed:
rotate knob towards +.

! Caution!
Before removing the brush, reduce the speed.

Setting the water flow rate

- Set the water flow rate with the control knob according to the dirt on the floor covering.

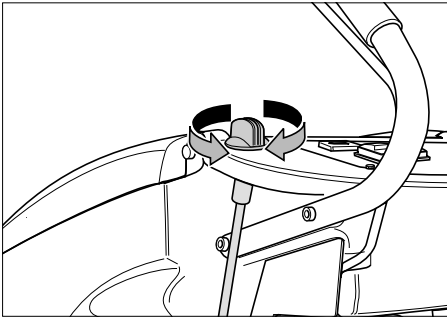

i Information:
Start cleaning on a low water flow rate. Gradually increase the water flow rate until the desired cleaning result is obtained.

Lowering the suction bar

- Press down the lever; the suction bar is lowered.

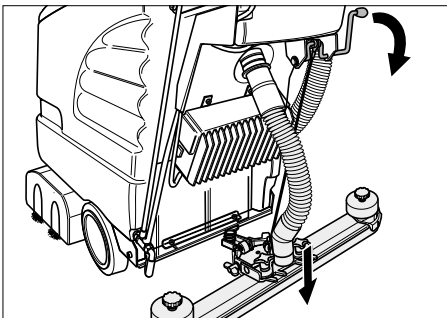

- Switch on the suction motor with the switch.

i Information:
The suction bar automatically adapts itself to the floor conditions and does not require any special adjustment. To improve the vacuuming result, the suction bar can be rotated or tilted.

Switching on the brush head

! Caution!
To prevent damage to the floor, do not operate the unit on the spot.

- Actuate the trigger lever, the brush motor starts.

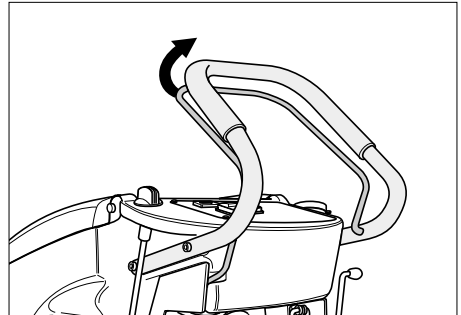

Stopping and switching off the unit

- Close control knob for water flow rate.
- Move the unit forwards another 1–2 m to extract any remaining water.
- Switch off the brush mode switch and suction motor.
- Raise the suction bar.
- Swivel down the running gear and lock.

! Caution!
When work is complete, the disc brushes or the brush rollers must be unloaded (risk of deforming the brushes).

Draining the dirty water

Caution!
 Observe local regulations for the treatment of waste water.

- Take the drainage hose out of the holder and place in a suitable receptacle. Drain off the dirty water by opening the metering equipment. Then rinse out the dirty-water tank with fresh water.

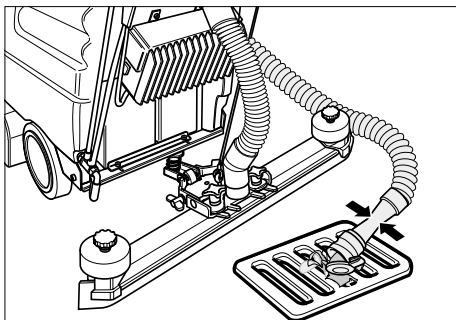

Drain off the fresh water.

- Open the latch on the fresh-water tank with a suitable implement (e.g. a coin).

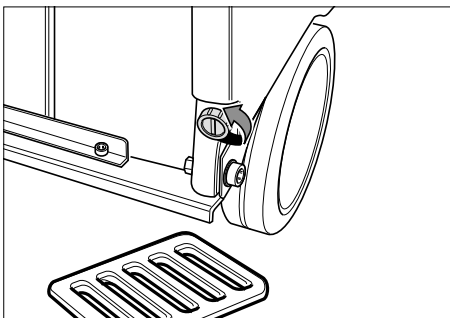

Adjusting the suction bar

Rotating the suction bar

To improve the pick-up result on ceramic floors (crevices), the suction bar can be rotated by up to 5°:

- Loosen the star knobs.
- Rotate the suction bar.

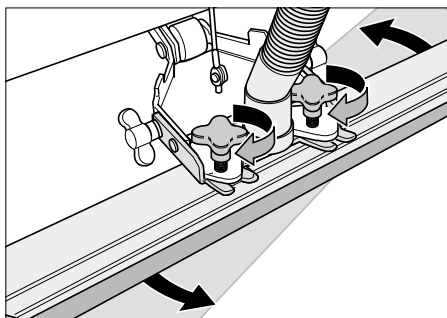

- Tighten the star knobs.

Tilting the suction bar

If the suction result is unsatisfactory, the straight suction bar can be tilted.

- Loosen the wing nut.
- Tilt the suction bar.

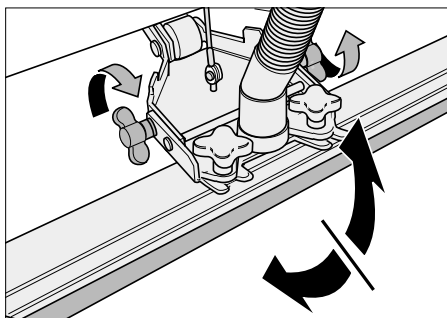

- Tighten the wing nut.

Care and maintenance



Risk of injury!

Before working on the unit, always switch off the brush mode switch and suction motor and pull out the battery charger mains plug.

- Drain off and dispose of dirty water and any residual cleaning liquid.

Maintenance schedule

After work



Caution!

Do not spray the unit with water or use any aggressive detergents.

- Drain off the dirty water.
- Rinse out the dirty-water tank with fresh water.
- Clean the outside of the unit.
- Check the fluff strainer and, if required, clean.
- Remove the squeegee blades, check for wear and, if required, replace.
- Check the brushes for wear and, if required, replace.

Monthly

- Check the battery terminals for oxidation and, if required, lubricate with terminal grease. Ensure that the connection cables are secure.
- Check the condition of the container cover seals and, if required, replace.
- If non-maintenance-free batteries are used, check the acid concentration of the cells.

Annually

- Have customer service conduct the stipulated inspection.

Maintenance procedures

Replacing the squeegee blades

- Unscrew the star knobs.

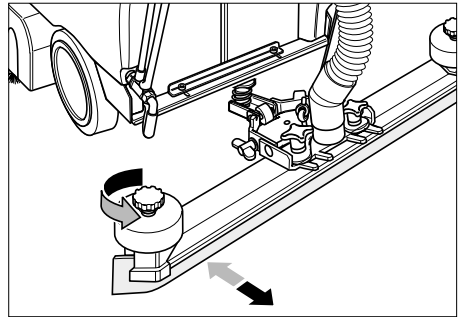

- Pull off the plastic parts.
- Remove the squeegee blades.
- Insert new rubber strips.
- Push on the plastic parts.
- Screw in and tighten star knobs.

Replacing the roller brushes

- Loosen the wing nuts.
- Remove the bearing cover.

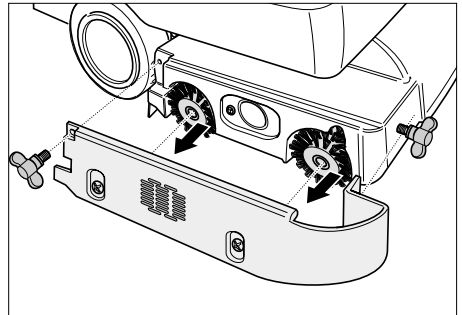

- Remove both roller brushes, insert new ones (note hexagon fixtures for the roller brushes).

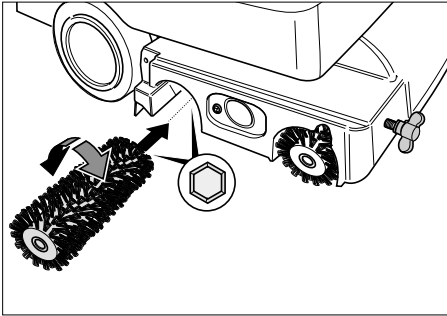

- Attach bearing cover.
- Tighten the wing nuts.

Replacing disc brushes

- Rotate propulsion to slow speed (-).
- Raise the disc brushes.
- Rotate disc brushes by approx. 45° in an anti-clockwise direction.
- Pull down and remove disc brushes.
- Insert the new disc brushes in reverse sequence.
- Rotate propulsion to the desired speed (+).

Maintenance agreement

To ensure that the unit operates reliably, maintenance agreements can be concluded with the appropriate Kärcher sales office.

Frost protection

If there is a risk of frost

- Drain the fresh-water and dirty-water tanks.
- Put the unit in a room which is protected from frost.

Transportation

- If transporting the unit by vehicle, secure the unit with tension belts/ropes to prevent it from sliding.
- Remove the brushes to prevent them from becoming damaged.

Spare parts

You will find a list of spare parts at the end of these operating instructions.

Warranty

The warranty terms issued by our authorised marketing company are valid in every country. We remedy any fault in the cleaner free of charge within the warranty period providing the cause of the fault proves to be a material or manufacturing error.

If making a claim under the guarantee, please consult your dealer or local authorised customer service centre and provide your receipt of purchase.

EU Declaration of Conformity

We hereby declare that the equipment described below conforms to the relevant fundamental safety and health requirements of the appropriate EU Directives, both in its basic design and construction as well as in the version marketed by us.

This declaration will cease to be valid if any modifications are made to the machine without our express approval.

Product: **brush cleaning unit**

Model: **1.127-xxx**

Relevant EU Directives:

EU Machinery Directive (98/37/CE)

EU Low-Voltage Equipment Directive (73/23/EEC) amended by 93/68/EEC

EU Directive on Electromagnetic Compatibility (89/336/EEC) amended by 91/263/EEC, 92/31/EEC, 93/68/EEC

Harmonised standards applied:

DIN EN 60 335-1 DIN EN 60 335-2-29

DIN EN 60 335-2-72

DIN EN 55 014-1: 2000+A1: 2001

DIN EN 55 014-2: 1997 DIN EN 61 000-3-2: 2000

DIN EN 61 000-3-3: 1995+A1: 2001

National standards applied: –

Appropriate internal measures have been taken to ensure that series-production units conform at all times to the requirements of current EU Directives and relevant standards.

The signatories are empowered to represent and act on behalf of the company management.

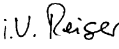

S. Reiser



H. Jenner

Alfred Kärcher GmbH & Co. KG

Cleaning Systems

D-71349 Winnenden

Alfred Kärcher Kommanditgesellschaft.

Sitz Winnenden;

Registergericht: Waiblingen, HRA 169.

Persönlich haftende Gesellschafterin:

Kärcher Reinigungstechnik GmbH, Sitz Winnenden,

2404 Registergericht Waiblingen, HRB

Geschäftsführer: Dr. Bernhard Graf,

Hartmut Jenner, Georg Metz

Troubleshooting



Risk of injury!

Before working on the unit, always switch off the brush mode switch and suction motor and pull out the battery charger mains plug.

- Drain off and dispose of dirty water and any residual cleaning liquid.

If faults cannot be rectified with the aid of this table, contact customer service.

Fault	Remedial action
Unit cannot be started.	Press in the overload fuse. Check batteries; if required, replace.
Inadequate water flow rate.	Check fresh-water level; if required, top up tank. Check hoses for blockages; remove any blockages.
Inadequate suction power.	Clean container cover seals and check for leaks; if required, replace. Clean fluff strainer. Clean squeegee blades on the suction bar; if required, replace. Check suction hose for blockages; remove any blockages. Check suction hose for leaks; if required, replace. Check whether metering valve on the dirty-water drainage hose is closed. Check the setting of the suction bar.
Unsatisfactory cleaning result.	Check the brushes for wear and suitability and, if required, replace.
Brushes do not rotate.	Check whether the brushes are blocked by foreign objects; if required, remove foreign objects.

Accessories

The unit can be fitted with various accessories for a particular cleaning task.

Ask for our catalogue or visit us on the Internet at www.karcher.com.

Designation	Part no. BR 530	Part no. BR 530 XL	Description	Quantity	
				Quan- tity	required for unit
Brush roller, white (standard)	5.762-169	5.762-208	for maintenance cleaning of very dirty floors	1	2
Brush roller, black (soft)	5.762-172	5.762-211	for polishing and for maintenance cleaning of sensitive floors	1	2
Brush roller red (high/low)	5.762-170	5.762-209	for scrubbing of structured floors (safety tiles, etc.)	1	2
Brush roller, grey (hard)	5.762-171	5.762-210	for basic cleaning of very dirty floors and for removal of coatings (e.g. wax, acrylates)	1	2
Pad roller shaft	4.762-184	4.762-214	for housing roller pads	1	2
Roller pad (white)	6.369-388	6.369-388	for fine polishing of floors	20	60 (XL: 80)
Roller pad (red)	6.369-453	6.369-453	for cleaning of slightly dirty floors	20	60 (XL: 80)
Roller pad (green)	6.369-452	6.369-452	for cleaning of normal to very dirty floors	20	60 (XL: 80)
Roller pad (yellow)	6.369-451	6.369-451	for polishing of floors	20	60 (XL: 80)

Designation	Part no. BD 530	Part no. BD 530 XL	Description	Quantity	
				Quan- tity	required for unit
Disc brushes, natural (soft)	6.906-056	6.905-866	for polishing of floors	1	1
Disc brush, white	6.906-054	6.905-864	for cleaning of slightly or sensitive floors	1	1
Disc brush, grey Grit (hard)	6.906-055	6.905-865	for cleaning of very dirty floors	1	1
Driving plate	6.906-332	6.906-331	for housing pads	1	1
Disc pad (red)	6.369-024	6.369-017	for cleaning of slightly dirty floors	5	1
Disc pad (green)	6.369-023	6.369-016	for cleaning of moderately dirty floors	5	1
Disc pad (black)	6.369-022	6.369-015	for cleaning of very dirty floors	5	1

Designation	Part no. BR/BD 530	Part no. BR/BD 530 XL	Description	Quantity	
				Quan- tity	required for unit

One-sided rubber strips

Rubber squeegee, blue	6.273-185	6.273-185	standard	pair	1 pair
Rubber squeegee, brown	6.273-168	6.273-168	oil-resistant	pair	1 pair
Suction bar, straight	4.777-027	4.777-027	standard	1	1
Suction bar, curved	4.777-028	4.777-028	standard	1	1

Reversible rubber strips (only for suction bars 4.777-047 and 4.777-054)

Suction bar, straight	4.777-047	4.777-047	standard	1	1
Suction bar, curved	4.777-054	4.777-054	standard	1	1
Rubber squeegee, blue	6.273-204	6.273-204	standard	1	1
Rubber squeegee, brown	6.273-207	6.273-207	oil-resistant	1	1

Technical Specifications

	Unit	BR 530 (BR 530 XL)	BD 530 (BD 530 XL)
Power			
Nominal voltage	V	24	24
Battery capacity	Ah (5h)	75	75
Power consumption	W	1200 (1560)	1200 (1560)
Suction motor output	W	500	500
Brush motor output	W	600	600
Suction			
Suction power, air flow rate	l/s	30	30
Suction power, vacuum	mbar	140	140
Cleaning brush			
Operating width	mm	460 (530)	460 (530)
Diameter	mm	96	460 (530)
Brush speed	rpm	1500	140
Dimensions and weight			
Theoretical surface performance	m ² /h	1840 (2120)	1840 (2120)
Volume	l	40/40	40/40
Volume, fresh/dirt-water tanks			
Total weight	kg	150 (155)	150 (155)
Noise emission			
Sound pressure level (EN 60704-1)	dB(A)	70	70
Unit vibration			
Total vibration value (ISO 5349)	m/s ²	0.4	0.4

BR 530 BAT

1.127-331.0 - Package
1.127-361.0

BR 530 XL BAT

1.127-431.0 - Package
1.127-461.0

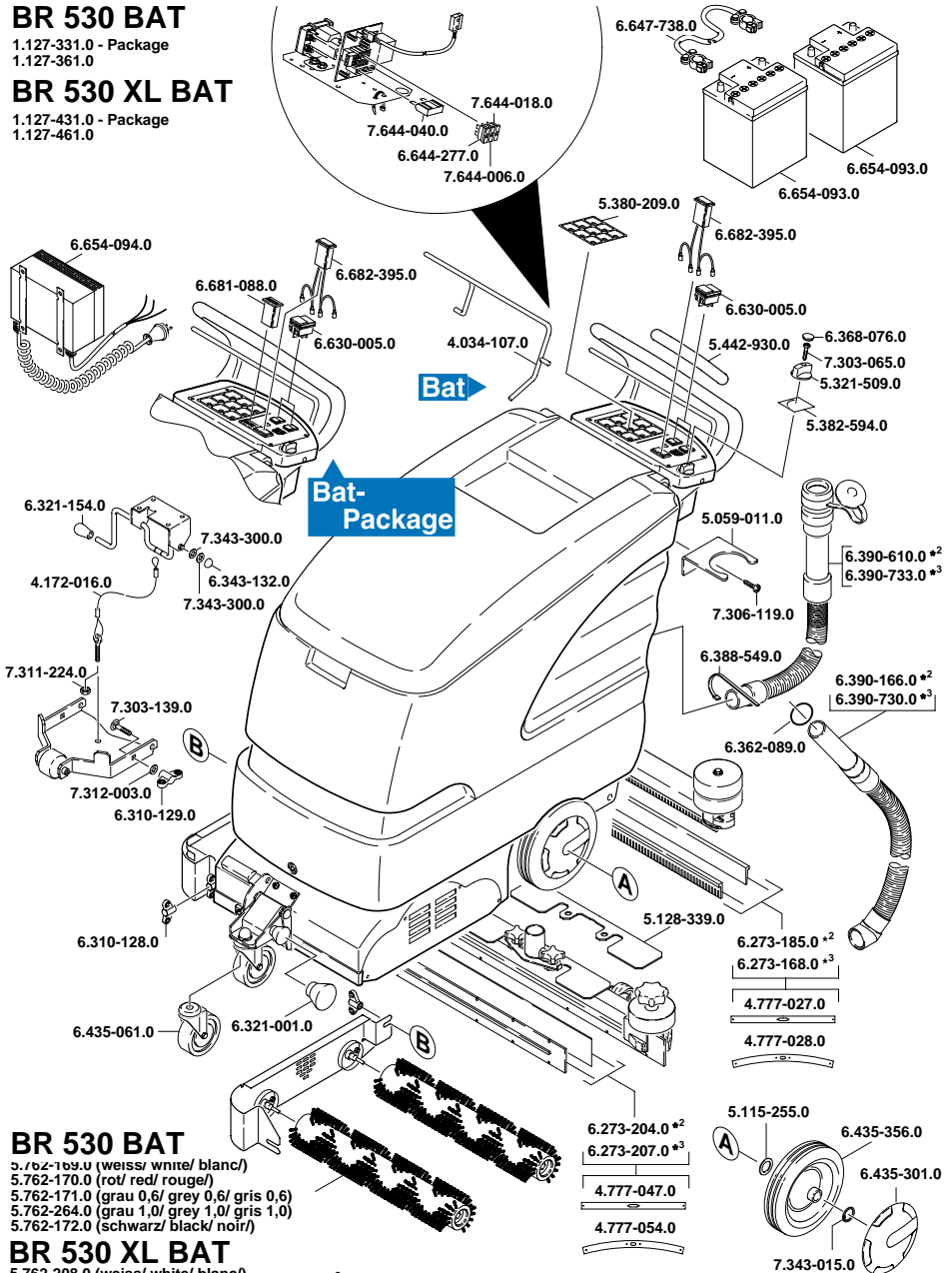

BR 530 BAT

5.762-169.0 (weiss/ white/ blanc)
5.762-170.0 (rot/ red/ rouge)
5.762-171.0 (grau 0,6/ grey 0,6/ gris 0,6)
5.762-264.0 (grau 1,0/ grey 1,0/ gris 1,0)
5.762-172.0 (schwarz/ black/ noir)

BR 530 XL BAT

5.762-208.0 (weiss/ white/ blanc)
5.762-209.0 (rot/ red/ rouge)
5.762-210.0 (grau 0,6/ grey 0,6/ gris 0,6)
5.762-263.0 (grau 1,0/ grey 1,0/ gris 1,0)
5.762-211.0 (schwarz/ black/ noir)

⁺² (standard/ standard/
standard)

⁺³ (ölfest/ oil resistant/
résistant à l'huile)

BD 530 BAT

1.127-351.0 - Package
1.127-371.0

BD 530 XL BAT

1.127-451.0 - Package
1.127-471.0
1.127-476.0 - Package

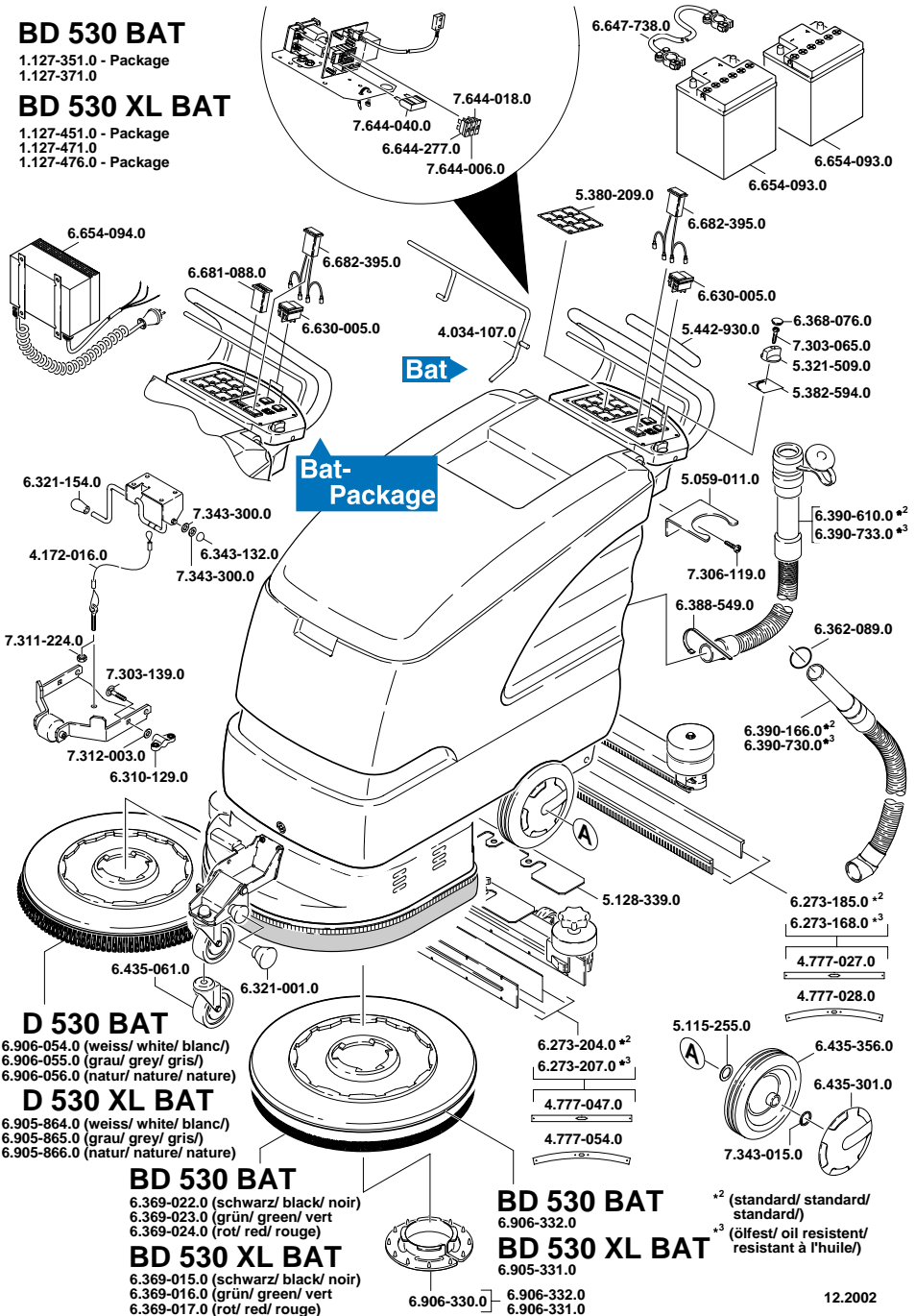

D 530 BAT

6.906-054.0 (weiss/ white/ blanc)
6.906-055.0 (grau/ grey/ gris)
6.906-056.0 (natur/ nature/ nature)

D 530 XL BAT

6.905-864.0 (weiss/ white/ blanc)
6.905-865.0 (grau/ grey/ gris)
6.905-866.0 (natur/ nature/ nature)

BD 530 BAT

6.369-022.0 (schwarz/ black/ noir)
6.369-023.0 (grün/ green/ vert)
6.369-024.0 (rot/ red/ rouge)

BD 530 XL BAT

6.369-015.0 (schwarz/ black/ noir)
6.369-016.0 (grün/ green/ vert)
6.369-017.0 (rot/ red/ rouge)

BD 530 BAT

6.906-332.0

BD 530 XL BAT

6.905-331.0