

SERVICE MANUAL

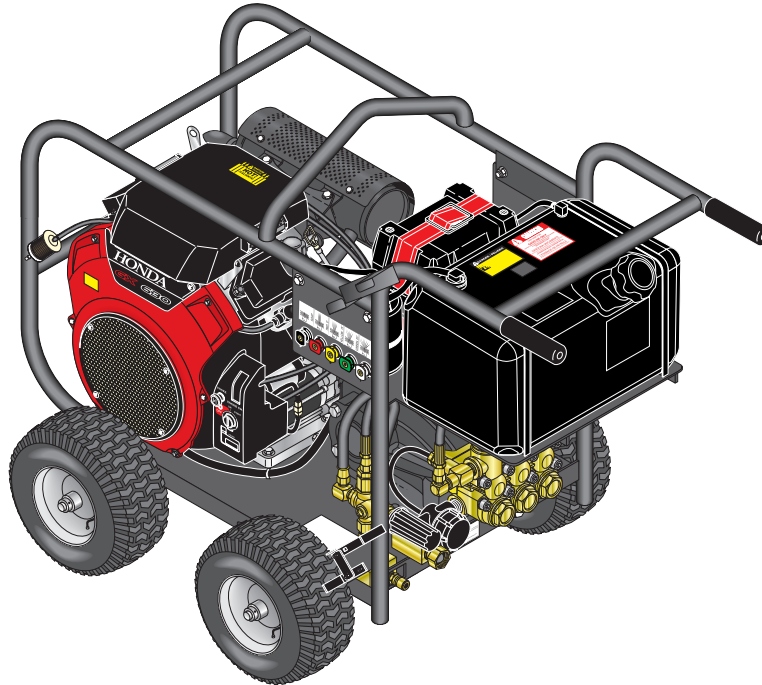

MODEL #	ORDER #
BD-405039E	1.107-023.0
BD-455039E	1.107-024.0
BD-343089E	1.107-083.0
BD-373539	1.107-021.0
BD-404029	1.107-022.0
MP-455034E	1.107-002.0
MP-343084E	1.107-082.0
MP-373534	1.107-001.0
HD 4.0/50 Pb CAGE	1.575-200.0
HD 4.5/50 Pb CAGE	1.575-201.0
HD 3.4/30 Db CAGE	1.575-202.0
HD 3.7/35 Pb CAGE	1.575-205.0
HD 4.0/40 Pb CAGE	1.575-207.0
BR-405037E	1.107-147.0
BR-455037E	1.107-148.0
BR-343087E	1.107-149.0
BR-373537	1.107-150.0
BR-404027	1.107-151.0
BR-455037E	1.107-255.0
BR-405037E	1.107-256.0

CONTENTS

Single Axle Exploded View and Parts List	3-4
Dual Axle Exploded View and Parts List.....	5-7
Specifications.....	8-9
Hose and Spray Gun Assembly.....	10
PX Pump Exploded View and Parts List.....	11-12
M.3 Pump Exploded View and Parts List.....	13-14
HHC 930 Pump Exploded View and Parts List.....	15-16
T.1 Pump Exploded View and Parts List.....	17-18
VRT3 Unloader Exploded View and Parts List.....	19
VB350/4 Unloader Exploded View and Parts List.....	20
Troubleshooting	21-22

Model Number _____

Serial Number _____

Date of Purchase _____

The model and serial numbers will be found on a decal attached to the pressure washer. You should record both serial number and date of purchase and keep in a safe place for future reference.

EXPLODED VIEW - SINGLE AXLE

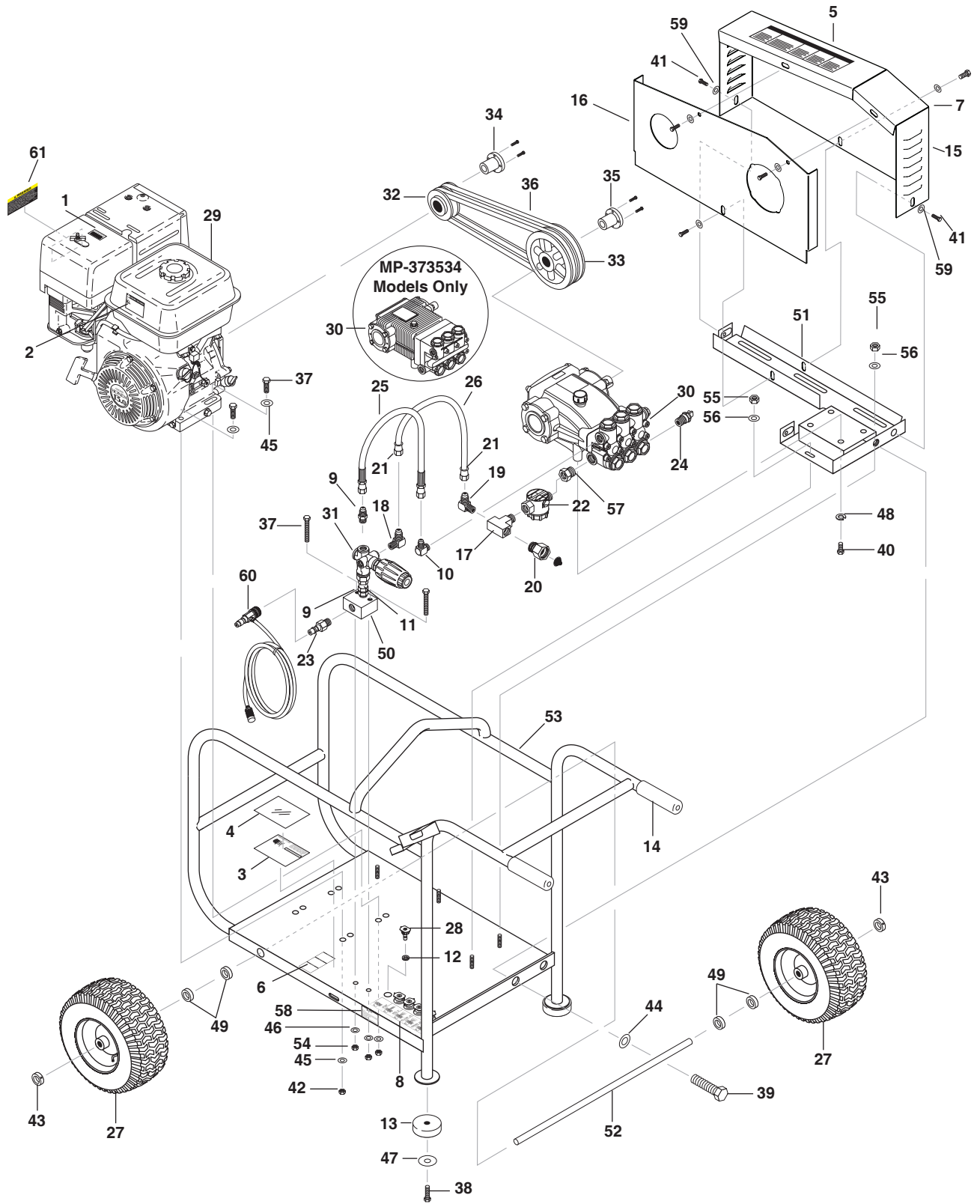

EXPLODED VIEW PARTS LIST- SINGLE AXLE

ITEM	PART NO.	DESCRIPTION	QTY	ITEM	PART NO.	DESCRIPTION	QTY
1	9.800-006.0	Label, "Hot/Caliente" w/ Arrows Warning	1	31		Unloader, See Specifications	
2	9.800-008.0	Label, Danger Cool Engine	1	32		Engine Pulley, See Specifications	
3	8.932-968.0	Label, Intended For Outdoor Use	1	33		Pump Pulley, See Specifications	
4	9.800-034.0	Label, Clear Lexan, 2-1/4" x 4-1/2"	1	34		Engine Bushing, See Specifications	
5	9.800-036.0	Label, Warning, Pictoral, Small	1	35		Pump Bushing, See Specifications	
6	9.803-842.0	Label, Instructions	1	36		Belt, See Specifications	
7	8.900-870.0	Label, Belt Guard, BR	1	37	9.802-728.0	Bolt, 3/8" x 2" Nc HH	6
	9.800-110.0	Label, Belt Guard, HD	1	38	9.802-723.0	Bolt, 3/8" x 1-1/2", Nc HH	2
	8.901-145.0	Label, Belt Guard, BD	1	39	9.802-740.0	Bolt, 1/2" x 3-1/2", Nc HH	1
	8.750-465.0	Label, Belt Guard ,MP	1	40	9.802-744.0	Bolt, 10mm x 20mm, HH	4
8	8.932-967.0	Label, Nozzle Identification	1	41	9.802-700.0	Bolt, 1/4-20 x 3/4", Nc HH	6
9	9.802-036.0	Nipple, 1/2" JIC, 3/8" Pipe	2	42	9.197-003.0	Nut, 3/8" ESNA, Nc	4
10	9.802-039.0	Elbow, 1/2" JIC, 3/8", 90°	1	43	9.802-782.0	Collar, 5/8" Bore Shaft 3010	2
11	9.802-048.0	Swivel, 1/2" JIC Fem, 3/8" Male	1	44	9.802-809.0	Washer, 1/2" Flat	1
12	9.802-064.0	Grommet, Rubber, Nozzle Holder	5	45	9.802-807.0	Washer, 3/8" Flat, SAE	8
13	9.802-066.0	Pad, Soft Rubber, 50 Duro	2	46	9.802-807.0	Washer, 3/8" Flat, SAE	2
14	9.802-070.0	Grip, 1" Square, Handle	2	47	9.802-817.0	Washer, 3/8" x 1"	2
15	8.917-886.0	Plate, Belt guard front cover	1	48	9.802-816.0	Washer, 7/16", Lock Split Ring	4
16	8.917-889.0	Plate, Belt Guard Back Cover	1	49	8.751-374.0	Spacer 5/8 X 1,25 Black	4
17	9.802-118.0	Elbow, 1/2" Street, Brass	1	50	9.802-870.0	Block, Unloader, 3/8" x 3/8", 1.25 Steel	1
18	9.802-129.0	Elbow, 1/2" JIC x 3/8", 90°	1	51	8.917-893.0	Assy black, Slider Pump/Belt Guard Mount	1
19	9.802-131.0	Elbow, 1/2" JIC x 1/2", 90°	1		8.917-888.0	Assy black, Slider Pump/Belt Guard Mount (BD-373539 only)	1
20	9.802-146.0	Swivel, 1/2" MP x 3/4" GHF w/ Strainer	1		8.918-127.0	Assy Blk, Slider, Pump/Sheet Metal Guard	1
21	9.802-151.0	Swivel, 1/2" JIC Fem, Push-On	2	52	8.908-396.0	Axle, Front	1
22	9.802-163.0	Strainer, 1/2" PA, Inline Plastic	1	53	8.912-442.0	Assy, Weld, CW Cage, Small Black	1
23	9.802-171.0	Nipple, 3/8" x 3/8" NPT ST Male	1		8.912-441.0	Assy, Weld, CW Cage, Small Red	1
24	8.707-256.0	Pump Protector, 1/2" PTP	1	54	9.197-003.0	Nut, 3/8" ESNA, Nc	2
25	8.918-424.0	Hose, 3/8" x 25", 2 Wire, Pres- sure Loop	1	55	9.802-776.0	Nut, 5/16" ESNA	4
26	9.802-259.0	Hose, 1/2", Push-On	15"	56	8.718-980.0	Washer, 5/16" Flat	4
27	8.754-435.0	Wheel & Pu Tire Assy, 12" Steel Rim	2	57	8.706-984.0	Adapter, 1/2 x 1/2 (5000 PSI Models)	1
28	9.802-295.0	Nozzle, SAQCMEG 0004, Red (3200, 3500 PSI)	1	58	9.800-049.0	Label, Manufacturer's Cleaning Solution	1
	9.802-296.0	Nozzle, SAQCMEG 1504, Yellow (3200, 3500 PSI)	1	59	9.802-802.0	Washer, 1/4" Flat	7
	9.802-297.0	Nozzle, SAQCMEG 2504, Green (3200, 3500 PSI)	1	60	9.802-225.0	Chemical Injector Assy, 3-5 GPM, .83	1
	9.802-298.0	Nozzle, SAQCMEG 4004, White (3200, 3500 PSI)	1	61	8.751-096.0	Label, Regulation 4442.6	1
29		Engine, See Specifications					
30		Pump, See Specifications					

EXPLODED VIEW - DUAL AXLE

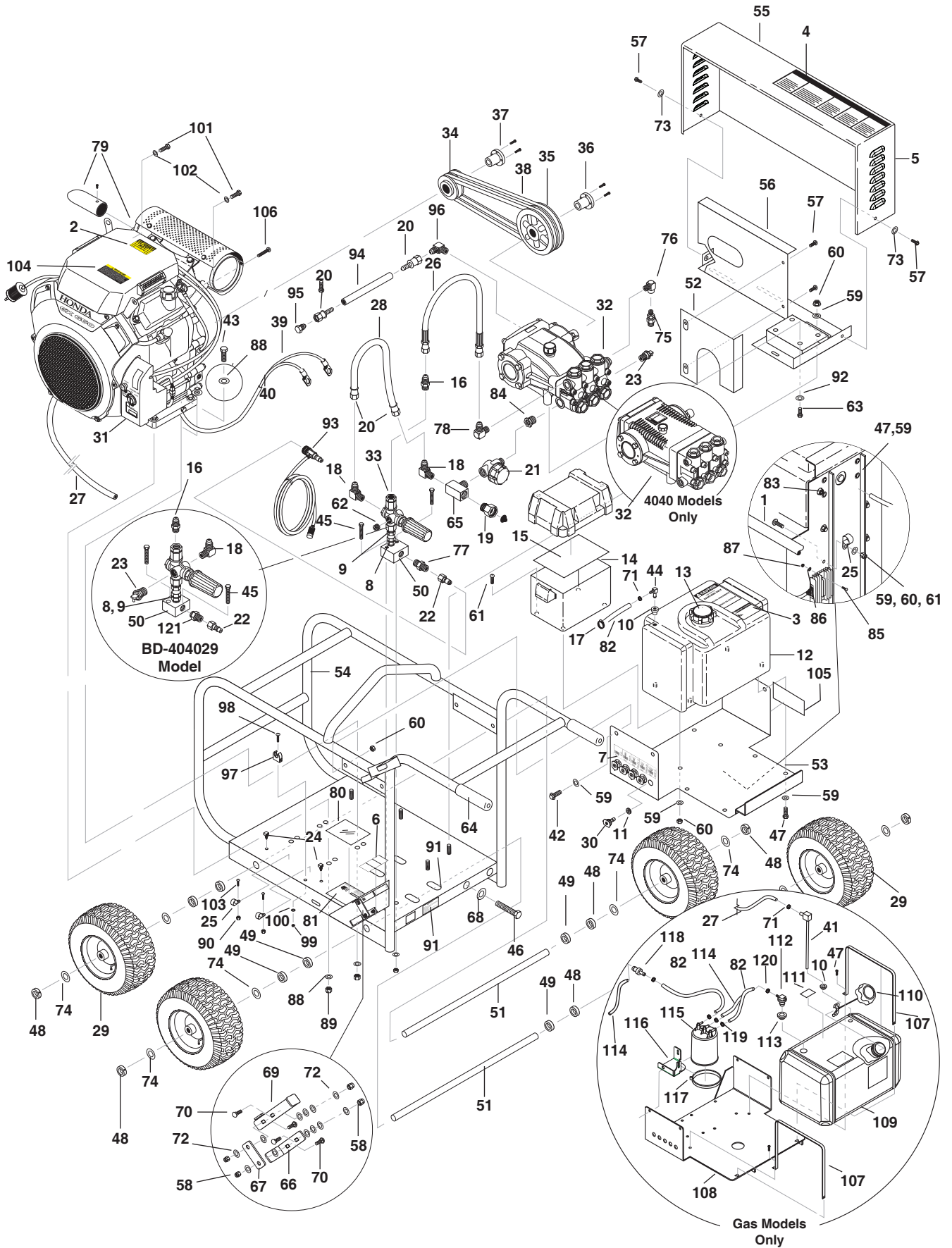

EXPLODED VIEW PARTS - DUAL AXLE

ITEM	PART NO.	DESCRIPTION	QTY	ITEM	PART NO.	DESCRIPTION	QTY
1	9.800-001.0	Label, This Tank For Gas Only (5000 PSI Models)	1	30	9.802-291.0	Nozzle, SAQCMEG, 0003.5, Red (4.0 GPM/5000 PSI)	1
	9.800-000.0	Label, Diesel (Diesel Models)	1		9.802-292.0	Nozzle, SAQCMEG 1503.5, Yellow (4.0 GPM/5000 PSI)	1
2	9.800-006.0	Label, "Hot/Caliente" w/Arrows	1		9.802-293.0	Nozzle, SAQCMEG, 2503.5, Green (4.0 GPM/5000 PSI)	1
3	9.800-008.0	Label, Danger Cool Engine (5000 PSI Models)	1		9.802-294.0	Nozzle, SAQCMEG 4003.5, White (4.0 GPM/5000 PSI)	1
4	9.800-036.0	Label, Warning Pictoral (Small)	1		9.802-295.0	Nozzle, SAQCMEG 0004, Red (4.5 GPM, Diesel & 4000 PSI Models)	1
5	9.800-047.0	▲ Label, Logo, Belt Guard, HD	1		9.802-296.0	Nozzle, SAQCMEG 1504, Yellow (4.5 GPM, Diesel & 4000 PSI Models)	1
	8.900-870.0	▲ Label, Logo, Belt Guard, BR	1		9.802-297.0	Nozzle, SAQCMEG 2504, Green (4.5 GPM, Diesel & 4000 PSI Models)	1
	8.901-144.0	▲ Label, Logo, Belt Guard, BD	1		9.802-298.0	Nozzle, SAQCMEG 4004, White (4.5 GPM, Diesel & 4000 PSI Models)	1
	8.750-465.0	▲ Label, Logo, Belt Guard, MP	1		9.802-311.0	Nozzle COMPL, QCCEM-6540, Brass	1
	8.753-796.0	▲ Label, Logo, Belt Guard (255.0)	1	31		Engine, See Specifications Pages	
6	9.803-842.0	Label, Instructions	1	32		Pump, See Specifications Pages	
7	9.800-010.0	Label, Nozzle Identification	1	33		Unloader, See Specifications Pages	
8	9.802-036.0	Nipple, 1/2" JIC, 3/8" Pipe	1	34		Engine Pulley, See Specifications Pages	
9	9.802-048.0	Swivel, 1/2" JIC Fem, 3/8" Male	1	35		Pump Pulley, See Specifications Pages	
10	9.802-053.0	Bushing, Rubber, Nitrile (Honda and Kohler/Lombardini Models)	2	36		Pump Bushing, See Specifications Pages	
11	9.802-064.0	Grommet, Rubber, Nozzle Holder	5	37		Engine Bushing, See Specifications Pages	
12	9.802-079.0	Tank, Encore, 5 Gallon Tank	1	38		Belts, See Specifications Pages	
13	9.802-089.0	Cap, Fuel Tank, Plastic	1	39	9.802-503.0	Cable, Battery, 32" Red, 4 Ga	1
14	9.802-090.0	Battery, Box	1	40	9.802-504.0	Cable, Battery, 36" Black, 4 Ga	1
15	9.802-091.0	Plate, Battery Box, Small, Polypro	1	41	9.803-531.0	Diptube Assy, Plastic, 10" Long	1
16	9.802-036.0	Nipple 1/2" JIC x 3/8" Male (Diesel & Vanguard Models)	1	42	9.802-710.0	Bolt, 5/16" x 1", NC HH	4
	9.802-037.0	Nipple, 1/2" JIC x 3/8" Female (Honda Models)	1	43	9.802-727.0	Bolt, 3/8" x 1-3/4" (Diesel Only)	4
17	8.750-933.0	Band Hose Clamp (Diesel Only)	1		9.802-728.0	Bolt, 3/8" x 2", NC, HH (5000 PSI Models Only)	4
18	9.802-131.0	Elbow, 1/2" JIC x 1/2", 90° (Honda and Kohler/Lombardini Models)	2	44	9.802-054.0	Elbow, Fuel Tank, Zinc (Diesel Models Only)	1
	9.802-129.0	Elbow, 1/2" JIC x 3/8", 90° (4000 PSI Models)	1	45	9.802-728.0	Bolt, 3/8" x 2" NC, HH	2
19	9.802-146.0	Swivel, 1/2"MP x 3/4" GHF w/Strainer	1	46	9.803-845.0	Bolt, 1/2" x 5" NC HH Tap (5000 PSI Models Only)	1
20	9.802-151.0	Swivel, 1/2" JIC Fem, Push-On	4		9.802-740.0	Bolt, 1/2" x 3-1/2", NC, HH (Diesel Models Only)	1
21	9.802-163.0	Filter, 1/2" MPT, PA Inline Plastic	1	47	9.802-751.0	Screw, 1/4" x 5/8", Phil PH MS	4
22	9.802-168.0	Nipple, 3/8" Female, 11,000 PSI (5000 PSI Models)	1	48	9.802-782.0	Collar, 5/8" Bore Shaft	4
	9.802-171.0	Nipple, 3/8" x 3/8" NPT ST Male (Diesel Models Only)	1	49	8.751-374.0	Spacer 5/8 X 1,25 Black	8
23	8.707-256.0	Pump Protector, 1/2" PTP (5000 PSI Models)	1	50	9.802-870.0	Block, Unloader, 3/8" x 3/8", Brass	1
	8.707-254.0	Pump Protector, 3/8" PTP (BD-404029 Models Only)	1	51	8.918-839.0	Axle, Lrg Cw Cage, 31.25"	2
24	9.803-844.0	Cable Tie, Wrap (Honda and Kohler/Lombardini Models)	2	52	9.803-104.0	Guard, Belt, Rear Steel	1
25	9.802-207.0	Clamp, Round, 0.56 I.D.	1		8.922-624.0	Guard, Belt (255.0 Only)	1
26	8.918-421.0	Hose, 3/8" x 1/4", 2 Wire Pressure Loop	1	53	8.912-480.0	Assembly, Weld, Battery Brkt, CW Cage, Black	1
27	9.802-254.0	Hose, 1/4", Push-On, Fuel Line	5.41 ft.		9.803-847.0	Assembly, Weld, Battery Brkt, CW Cage, Red	1
28	9.802-259.0	Hose, 1/2", Push-On	1.25 ft.		8.912-502.0	Holder, Nozzle, Red	1
29	9.802-271.0	Wheel & Tire Assembly, 6"	4		8.921-215.0	Holder, Nozzle, Blk (HD 4.0/40, BR-404027)	1
				54	9.802-964.0	Assembly, Weld, Cage, Cw Blk	1
					8.912-486.0	Assembly, Weld, Cage, Cw Red	1
					8.922-617.0	Assembly, Weld, Cage (255.0)	1

EXPLODED VIEW PARTS - DUAL AXLE

ITEM	PART NO.	DESCRIPTION	QTY	ITEM	PART NO.	DESCRIPTION	QTY
55	9.803-304.0	Guard, Belt, Front, CW Cage, Lrg	1	87	9.802-773.0	Nut, 1/4" ESNA (5000 PSI)	2
	8.922-623.0	Guard, Belt, Front (255.0 Only)	1	88	9-802-807.0	Washer, 3/8" Flat	10
56	9.802-967.0	Assy, Weld, Slider, Cw Cage, Blk	1	89	9.197-003.0	Nut, 3/8" ESNA	6
	8.912-497.0	Assy, Weld, Slider, Cw Cage, Red	1	90	8.718-857.0	Nut, 10/24, Whiz Loc Flange	2
	9.803-846.0	Slider, Assembly, Black (Diesel)	1	91	9.800-049.0	Label, Manufacturer's Cleaning Solution	1
	8.922-622.0	Assy, Weld, Slider, Cage (255.0)	1	92	9.802-816.0	Washer, 7/16" Lock, Split Ring	4
57	9.802-765.0	Screw, 1/4" x 1/2" BH SOC CS	7	93	9.802-225.0	Chemical Injector Assy., 3-5 GPM, .83 (Diesel & Vanguard)	1
58	9.802-773.0	Nut, 1/4" ESNA, NC	4	9.802-226.0	Downstream Inj. Assy, 5000 PSI (5000 PSI Models Only)	1	
59	9.802-804.0	Washer, 5/16" Flat, SAE	20	94	9.802-259.0	Hose, 1/2" Push-On	14"
60	9.802-776.0	Nut, 5/16" ESNA, NC	12	95	9.802-126.0	Plug, 1/2" JIC	1
61	9.802-708.0	Screw, 5/16"-18 x 3/4" M PH, TRH	4	96	9.802-129.0	Elbow, 1/2" JIC x 3/8"	1
62	9.802-124.0	Plug, 1/4" Countersunk (5000 PSI Models Only)	1	97	9.802-203.0	Clamp, 1/2"	1
63	9.802-744.0	Bolt, 10mm x 20mm, HH	4	98	9.802-771.0	Screw, 10/32"	1
64	9.802-070.0	Grip, 1" Square Handle	2	99	9.804-567.0	Nut, 10/32"1	1
65	9.802-118.0	Tee, 1/2", Branch Male	1	100	9.802-802.0	Washer, 1/4" Flat, SAE	1
	9.802-996.0	Bracket, Brake Pad, Black	1	101	9.802-741.0	Bolt 8mm x 16mm (5000 PSI)	4
	8.912-019.0	Bracket, Brake Pad, Red	1	102	9.802-813.0	Split Washer 5/16 (5000 PSI)	4
66	8.922-519.0	Bracket, Brake Pad (255.0)	1	103	8.718-588.0	Terminal Battery Marine	2
	9.802-997.0	Linkage, Brake, Black	1	104	8.751-096.0	Label, Regulation 4442.6	1
	8.912-020.0	Linkage, Brake, Red	1	105	8.704-660.0	Label, Die-cut	1
67	8.920-520.0	Linkage, Bracke (255.0)	1	106	8.718-781.0	Screw, M5 X 8 X 40MM, Pan Head	1
	9.802-809.0	Washer, 1/2" Flat	1	107	8.921-463.0	Strap, Fuel Tank Carb, Black (Gas Models Only)	2
	9.802-966.0	Handle, Break, CW Cage, Black	1	8.922-621.0	Strap, Fuel Tank Carb (255.0)	2	
68	8.912-495.0	Handle, Brake, CW Cage, Red	1	108	8.921-471.0	Full Tank Carb Bracket (Gas Models Only)	1
	8.922-618.0	Handle, Brake (255.0)	1	8.922-619.0	Full Tank Carb Bracket (255.0)	1	
	9.802-705.0	Bolt, Carriage, Zinc, 1/4"-20 x 1.0 PLT	4	109	8.752-915.0	Tank, Gasoline, 7.25 GAL, Low-Perm (Gas Models Only)	1
70	9.802-210.0	Clamp, Hose, .46-.54 ST (Honda and Diesel Models)	2	110	8.750-674.0	Cap, Non-Vent, Unleaded, Carb (Gas Models Only)	1
71	9.802-802.0	Washer, 1/4" Flat, SAE	12	111	8.921-479.0	Label, CO10 Carb Compliance (Gas Models Only)	1
72	9.802-803.0	Washer, 1/4" Flat, Sae, Blk, Znc	5	112	8.751-059.0	Vent, remote assembly, CARB (Gas Models Only)	1
73	9.802-810.0	Washer, 5/8" Flat	8	113	8.751-215.0	Grommet, Remove Vent, Kelch (Gas Models Only)	1
74	9.803-843.0	Valve, Safety Relief, 6000PSI (5000 PSI Models Only)	1	114	8.711-785.0	Hose, 3/8" Push On (Gas Models Only)	1.67 ft.
75	9.802-030.0	Elbow, 3/8" Street, Female (5000 PSI Models Only)	1	115	8.751-380.0	Carbon Canister, 850cc (Gas Models Only)	1
	8.705-974.0	Nipple, 3/8" Hex Steel (5000 PSI Models Only)	1	116	8.921-468.0	Bracket, 850cc Canister (Gas Models Only)	1
76	9.802-039.0	Elbow, 1/2" JIC, 3/8", 90°	1	8.922-620.0	Bracket, 850cc Canister (255.0)	1	
	9.802-040.0	Elbow, 1/2" JIC, 1/2", 90° (BD-404029 Model Only)	1	117	8.752-918.0	Clamp, Hose, 4.5-2.5 x 9/16 SS (Gas Models Only)	1
77	8.750-497.0	Muffler, Honda, GX630/660 Right (5000 PSI Models Only)	1	118	9.802-141.0	Hose Barb, 1/4" X 3/8" (Gas Models Only)	1
	8.915-687.0	▲ Deflector, Exhaust, Honda	1	119	8.709-117.0	Clamp, Hose, UNI .62-.75 (Gas Models Only)	3
	9.803-631.0	▲ Muffler, Exhaust, Vanguard	1	120	6.390-126.0	Clamp, Hose, .46-.54 ST (Gas Models Only)	6
	9.803-867.0	▲ Guard, Muffler, Vanguard	1	121	8.706-309.0	Adapter, 3/8 X 3/8 Steel	1
	9.802-868.0	▲ Brace, Muffler Guard	1				
	8.718-028.0	▲ Muffler, Deflector, Vanguard	1				
78	9.800-034.0	Clear Lexan	1				
79	9.800-014.0	Label, Intended For Outdoor Use	1				
80	9.802-254.0	Hose, 1/4 Push-On (Diesel)	7.66 ft.				
81	9.802-035.0	Plug, 1/8" Square Head, Black	1				
82	9.802-148.0	Adaptor, 1/2" x 1/2"	1				
	8.706-925.0	Bushing, 3/4" x 1/2" Brass (BD-404029 Model Only)	1				
83	9.802-770.0	Screw, 1/4" x 1" (5000 PSI)	2				
84	9.802-803.0	Washer, 1/4" Flat, SAE, Black (5000 PSI Models)	2				

▲ Not Shown

SPECIFICATIONS

HD Models

Machine Model	Engine Pulley	Pulley Description	Engine Bushing#	Bushing Description	Pump Pulley	Pulley Description	Pump Bushing#
HD-4.0/50 Pb Cage	9.802-392.0	3TB34	9.802-404.0	P2 x 1"	9.802-396.0	3BK90H	9.802-402.0
HD-4.5/50 Pb Cage	9.802-392.0	3TB34	9.802-405.0	P2 x 1-1/8"	8.715-618.0	3BK80H	9.802-402.0
HD-3.4/30 Db Cage	9.802-383.0	2BK36H	9.802-399.0	H x 1"	9.802-388.0	2BK67H	9.802-402.0
HD-3.7/35 Pb Cage	8.715-576.0	2BK32H	9.802-399.0	H x 1"	8.715-593.0	2BK90H	9.802-402.0
HD-4.0/40 Pb Cage	9.802-382.0	2BK34H	9.802-399.0	H x 1"	8.715-593.0	2BK90H	9.802-403.0

BR Models

Machine Model	Engine Pulley	Pulley Description	Engine Bushing#	Bushing Description	Pump Pulley	Pulley Description	Pump Bushing#
BR-405037E	9.802-392.0	3TB34	9.802-404.0	P2 x 1"	9.802-396.0	3BK90H	9.802-402.0
BR-455037E	9.802-392.0	3TB34	9.802-405.0	P2 x 1-1/8"	8.715-618.0	3BK80H	9.802-402.0
BR-343087E	9.802-383.0	2BK36H	9.802-399.0	H x 1"	9.802-388.0	2BK67H	9.802-402.0
BR-373537	8.715-576.0	2BK32H	9.802-399.0	H x 1"	8.715-593.0	2BK90H	9.802-402.0
BR-404027	9.802-382.0	2BK34H	9.802-399.0	H x 1"	8.715-593.0	2BK90H	9.802-403.0

BD Models

Machine Model	Engine Pulley	Pulley Description	Engine Bushing#	Bushing Description	Pump Pulley	Pulley Description	Pump Bushing#
BD-405037E	9.802-392.0	3TB34	9.802-404.0	P2 x 1"	9.802-396.0	3BK90H	9.802-402.0
BD-455039E	9.802-392.0	3TB34	9.802-405.0	P2 x 1-1/8"	8.715-618.0	3BK80H	9.802-402.0
BD-343089E	9.802-383.0	2BK36H	9.802-399.0	H x 1"	9.802-388.0	2BK67H	9.802-402.0
BD-373539	8.715-576.0	2BK32H	9.802-399.0	H x 1"	8.715-593.0	2BK90H	9.802-402.0
BD-404029	9.802-382.0	2BK34H	9.802-399.0	H x 1"	8.715-593.0	2BK90H	9.802-403.0

MP Models

Machine Model	Engine Pulley	Pulley Description	Engine Bushing#	Bushing Description	Pump Pulley	Pulley Description	Pump Bushing#
MP-455034E	9.802-392.0	3TB34	9.802-405.0	P2 x 1-1/8"	8.715-618.0	3BK80H	9.802-402.0
MP-343084E	9.802-383.0	2BK36H	9.802-399.0	H x 1"	9.802-388.0	2BK67H	9.802-402.0
MP-373534	8.715-576.0	2BK32H	9.802-399.0	H x 1"	8.715-593.0	2BK90H	9.802-402.0

SPECIFICATIONS

Machine Description	Bushing Model	Belt Part No.	Belt Desc./Qty.	Pump Part No.	Unloader Part No.	Engine Description	Engine Part No.
HD-4.0/50 Pb Cage	24mm	8.749-965.0	3BX42 (1)	8.921-657.0	8.715-461.0	GX630 (688cc)	8.752-149.0
HD-4.5/50 Pb Cage	24mm	8.749-965.0	3BX42 (1)	8.921-657.0	8.715-461.0	GX660 (688cc)	8.752-148.0
HD-3.4/30 Db Cage	24mm	9.802-418.0	BX39 (2)	8.751-186.0	8.750-300.0	KD420 (401cc)	8.753-893.0
HD-3.7/35 Pb Cage	24mm	9.802-418.0	BX39 (2)	8.751-189.0	8.750-300.0	GX390 (390cc)	8.750-580.0
HD-4.0/40 Pb Cage	25mm	9.802-420.0	BX43 (2)	8.921-714.0	8.750-300.0	Vanguard (479cc)	8.715-065.0

Machine Description	Bushing Model	Belt Part No.	Belt Desc./Qty.	Pump Part No.	Unloader Part No.	Engine Description	Engine Part No.
BR-405037E	25mm	8.749-965.0	3BX42 (1)	8.921-657.0	8.715-461.0	GX630 (688cc)	8.752-149.0
BR-455037E	25mm	8.749-965.0	3BX42 (1)	8.921-657.0	8.715-461.0	GX660 (688cc)	8.752-148.0
BR-343087E	25mm	9.802-418.0	BX39 (2)	8.751-186.0	8.750-300.0	KD420 (401cc)	8.753-893.0
BR-373537	24mm	9.802-418.0	BX39 (2)	8.751-189.0	8.750-300.0	GX390 (390cc)	8.750-580.0
BR-404027	25mm	9.802-420.0	BX43 (2)	8.921-714.0	8.750-300.0	Vanguard (479cc)	8.715-065.0

Machine Description	Bushing Model	Belt Part No.	Belt Desc./Qty.	Pump Part No.	Unloader Part No.	Engine Description	Engine Part No.
BD-405037E	25mm	8.749-965.0	3BX42 (1)	8.921-659.0	8.715-461.0	GX630 (688cc)	8.752-149.0
BD-455039E	25mm	8.749-965.0	3BX42 (1)	8.921-659.0	8.715-461.0	GX660 (688cc)	8.752-148.0
BD-343089E	24mm	9.802-418.0	BX39 (2)	8.751-179.0	8.750-300.0	KD420 (401cc)	8.753-893.0
BD-373539	24mm	9.802-418.0	BX39 (2)	8.751-180.0	8.750-300.0	GX390 (390cc)	8.750-580.0
BD-404029	25mm	9.802-420.0	BX43 (2)	8.752-808.0	8.750-300.0	Vanguard (479cc)	8.715-065.0

Machine Description	Bushing Model	Belt Part No.	Belt Desc./Qty.	Pump Part No.	Unloader Part No.	Engine Description	Engine Part No.
MP-455034E	25mm	8.749-965.0	3BX42 (1)	8.921-655.0	8.715-461.0	GX660 (688cc)	8.752-148.0
MP-343084E	25mm	9.802-418.0	3BX39 (1)	8.751-166.0	8.750-300.0	KD420 (401cc)	8.753-893.0
MP-373534	24mm	9.802-418.0	BX39 (2)	8.921-710.0	8.750-300.0	GX390 (390cc)	8.750-580.0

HOSE & SPRAY GUN ASSEMBLY AND PARTS LIST

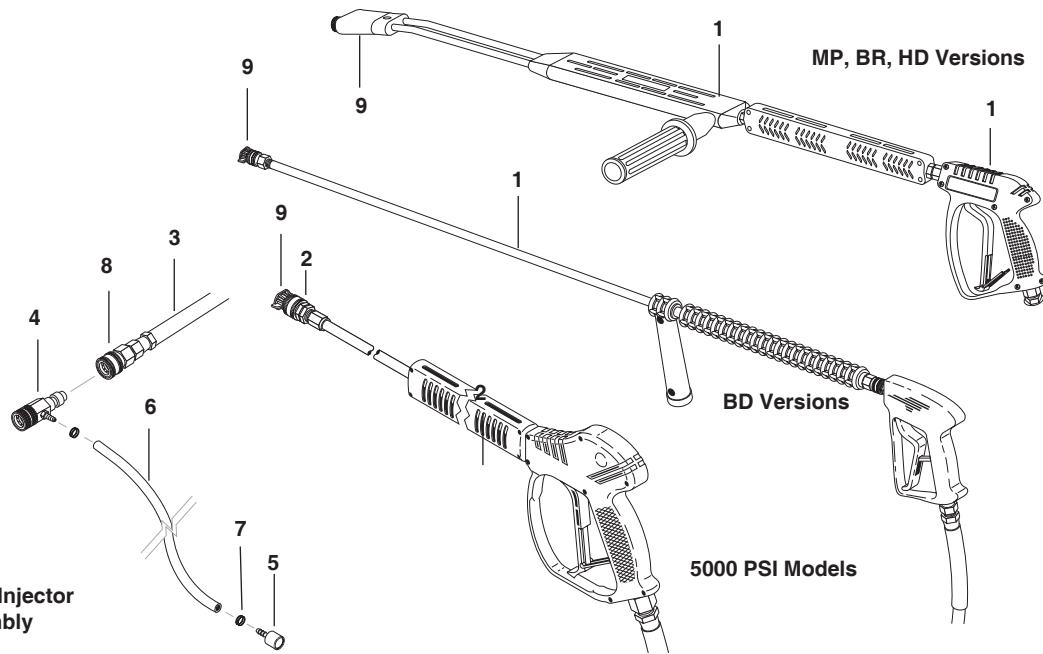

ITEM	PART NO.	DESCRIPTION	QTY	ITEM	PART NO.	DESCRIPTION	QTY
1	9.802-222.0	Wand, VP W/Coupler & Nozzle X-Series (BR and HD)	1	4	9.802-225.0	Injector Assembly, 3-5 GPM, 0.083 (Models to 4000 PSI)	1
	8.711-293.0	Wand, VP Lance, AL344 w/Coupler & Soap Nozzle (MP)	1		9.802-216.0	Injector Chem Non Adj. 3-5 GPM. 0.083	1
	8.904-425.0	Wand, Side Grip, 47.5" w/Couplers (BD Models)	1		9.802-217.0	Injector Assembly, 5500 PSI (5000 PSI Models)	1
	8.725-388.0	Wand, Single, 48" Insulated W/ Side Grip	1		9.802-167.0	Coupler, 3/8" Fem, 11,000 PSI	1
	9.802-164.0	Coupler, 1/4" Female Brass (BD Models)	1		9.802-168.0	Nipple, 3/8" Fem, 11,000 PSI	1
	8.710-384.0	Gun, St-1500, 5000 PSI, 10.4 Gpm (BR and HD Models)	1	5	8.707-057.0	Strainer, Plastic, 1/4" Hose Barb	1
	8.751-234.0	Gun, Landa, L1050, 5000 PSI 10.4 GPM	1	6	9.802-251.0	Tube, 1/4" X 1/2", Clear Vinyl	6 ft.
	8.904-490.0	Spray Gun Assembly with Nipple, Hotsy	1	7	6.390-126.0	Clamp, Hose, .46-.54 ST	2
	8.751-235.0	Gun, Hotsy, H1050, 5000 PSI 10.4 GPM	1	8	9.802-167.0	Coupler, 3/8" Fem, 11,000 PSI Snap-Tite (5000 PSI Models)	1
					9.802-166.0	Coupler, 3/8" Female	1
2	9.802-228.0	Spray Gun Assy w/ Wand & Coupler (5000 PSI Models)	1	9	9.802-295.0	Nozzle Saqcmeg, 0004, Red (All Except 4 GPM/5000 PSI)	1
	9.802-227.0	Spray Gun Wand 5000 PSI 52" (5000 PSI Models)	1		9.802-296.0	Nozzle Saqcmeg, 1504, Yellow (All Except 4 GPM/5000 PSI)	1
	9.802-165.0	Coupler 1/4" Male Brass	1		9.802-297.0	Nozzle Saqcmeg, 2504, Green (All Except 4 GPM/5000 PSI)	1
3	8.739-331.0	Hose, 3/8" x 50', 2W, TF, KA, SO-SW, CP (BR and HD Models to 4000 PSI)	1		9.802-298.0	Nozzle Saqcmeg, 4004, White (All Except 4 GPM/5000 PSI)	1
	8.739-346.0	Hose, 3/8" x 50', 2W, TS, KA SO-SW, HP-CP (BR and HD Models to 5000 PSI)	1		8.708-713.0	▲ Nozzle Kit, Size 04, 4-Pack (All Except 4 GPM/5000 PSI)	1
	8.739-330.0	Hose, 3/8" x 50', 2W, TF, LA SO-SW, CP (MP to 4000 PSI)	1		9.802-291.0	Nozzle Saqcmeg, 0003.5, Red (4 GPM/5000 PSI)	1
	8.918-088.0	Hose, 3/8" x 50', 2W, TS SO-SW, HIGH PRESS CP (MP Models to 5000 PSI)	1		9.802-292.0	Nozzle Saqcmeg, 1503.5, Yellow (4 GPM/5000 PSI Models)	1
	8.739-347.0	Hose, 3/8" x 50', 2W, TF, HO SO-SW, CP (BD to 4000 PSI)	1		9.802-293.0	Nozzle Saqcmeg, 2503.5, Green (4 GPM/5000 PSI Models)	1
	8.739-332.0	Hose, 3/8" x 50', 2W, TS, HO SO-SW, HP-CP (BD to 5000 PSI)	1		9.802-294.0	Nozzle Saqcmeg, 4003.5, White (4 GPM/5000 PSI Models)	1
					8.708-712.0	▲ Nozzle, Kit, Size 03.5, 4-Pack (4 GPM/5000 PSI)	1
					9.802-311.0	Nozzle, COMPL, QCHEM-6540, Brass	1

▲ Not Shown

PX SERIES PUMP EXPLODED VIEW PARTS LIST

8.921-655.0

8.921-659.0

8.921-657.0

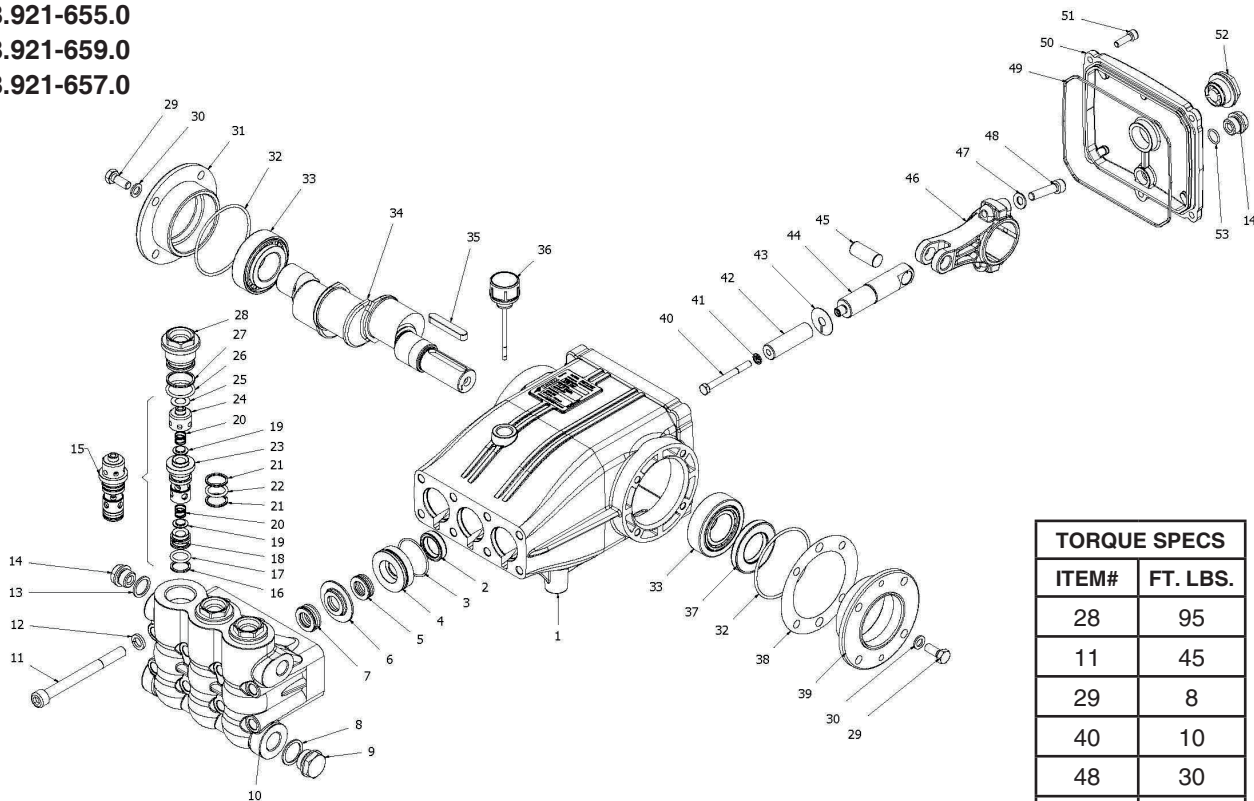

TORQUE SPECS	
ITEM#	FT. LBS.
28	95
11	45
29	8
40	10
48	30
51	8

ITEM	PART NO.	DESCRIPTION	QTY
1	8.752-825.0	Crankcase	1
2*	See Kit Below	Plunger Oil Seal	3
3*	See Kit Below	O'Ring, 2150 Ø1.78 x 37.82	3
4*	See Kit Below	Pressure Ring 16mm	3
5*	See Kit Below	U-Seal, 16mm	3
6*	See Kit Below	Intermediate Ring 16mm	3
7*	See Kit Below	U-Seal, 16mm	3
8	9.803-199.0	Copper Washer 1/2	1
9	9.802-926.0	Brass Plug, G1/2	1
10	8.753-502.0	Manifold Housing Ø16	1
11	8.753-503.0	Manifold Stud Bolt	8
12	9.802-890.0	Lock-Washer	8
13	8.719-008.0	Copper Washer 3/8	1
14	8.707-262.0	Brass Plug, G3/8	2
15	8.753-504.0	Valve Assembly	3
16*	See Kit Below	Back Ring	3
17*	See Kit Below	O'Ring, 119 Ø2.62 x 15.08	3
18*	See Kit Below	Valve Seat	3
19*	See Kit Below	Valve Plate	6
20*	See Kit Below	Valve Spring	6
21*	See Kit Below	Back Ring	6
22*	See Kit Below	O'Ring, 3068 Ø2.62 x 17.13	6
23*	See Kit Below	Valve Cage	3

ITEM	PART NO.	DESCRIPTION	QTY
24*	See Kit Below	Valve Cage	3
25*	See Kit Below	Copper Washer	3
26	8.753-505.0	O'Ring, 3093 Ø2.62 x 23.47	3
27	8.753-506.0	Back Ring	3
28	8.753-507.0	Valve Plug	3
29	8.752-830.0	Hexagonal Screw	8
30	9.802-884.0	Washer	8
31	9.803-182.0	Closed Bearing Housing	1
32	9.803-186.0	O'Ring, Ø2.62 x 71.12	2
33	9.803-160.0	Roller Bearing	2
34	8.753-508.0	Crankshaft, Ø24	1
35	9.803-293.0	Crankshaft Key	1
36	8.752-834.0	Oil Dipstick	1
37	9.803-139.0	Crankshaft Seal	3
38	9.803-177.0	Shim, .10mm	3
39	8.753-509.0	Bearing Housing	3
40*	8.752-841.0	Plunger Bolt	3
41*	8.752-820.0	Bonded Seal	3
42*	8.753-510.0	Plunger 16mm	3
43*	8.752-823.0	Copper Spacer	6
44	8.753-511.0	Plunger Rod	6
45	8.752-822.0	Connecting Rod Pin	1
46	8.752-821.0	Connecting Rod	1

PX SERIES PUMP EXPLODED VIEW PARTS LIST (CONT.)

ITEM	PART NO.	DESCRIPTION	QTY
47	9.802-889.0	Spring Washer	1
48	9.802-937.0	Screw, Connecting Rod	6
49	9.803-194.0	O'Ring, Ø2.62 x 152.07	1
50	8.752-826.0	Crankcase Cover	1
51	8.752-824.0	Cover Screw	5
52	9.803-202.0	Sight Glass, G3/4	1
53	9.803-906.0	O'Ring, Ø1.78 x 14.00	1
* Available in Kit (See Below)			

KIT NUMBERS	8.753-512.0	8.753-513.0	8.753-514.0	8.753-515.0	8.752-835.0
KIT DESCRIPTION	Plunger Seal 16 mm	Seal Packing 16 mm	Plunger 16 mm	Complete Valve	Plunger Oil Seals
ITEMS NUMBERS INCLUDED	3, 5, 7	3, 4, 5, 6, 7	40, 41, 42, 43	15	2
NUMBER OF CYLINDERS KIT WILL SERVICE	3	1	1	6	3

M.3 SERIES PUMP EXPLODED VIEW

- 8.751-189.0 KM4035R.3
- 8.751-180.0 HM4035R.3
- 8.751-186.0 KM3540R.3
- 8.751-179.0 HM3540R.3
- 8.751-166.0 LM3540R.3

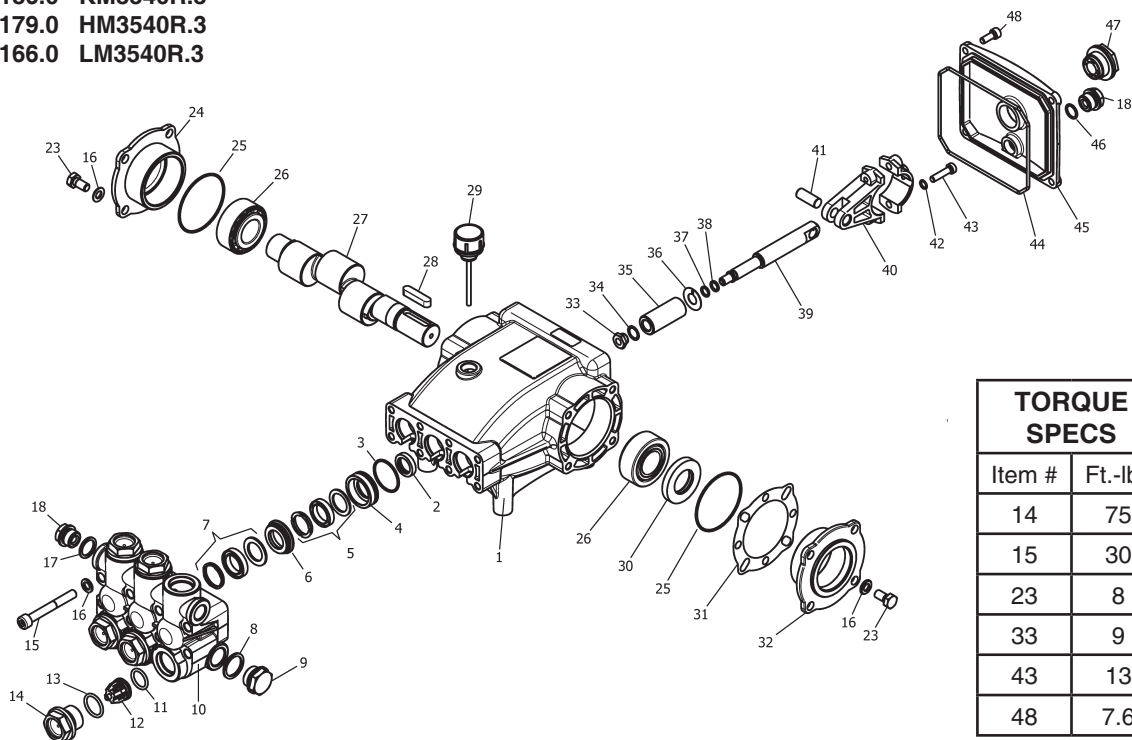

TORQUE SPECS	
Item #	Ft.-lbs
14	75
15	30
23	8
33	9
43	13
48	7.6

M.3 SERIES PUMP EXPLODED VIEW PARTS LIST

ITEM	PART NO.	DESCRIPTION	QTY	ITEM	PART NO.	DESCRIPTION	QTY
1	8.751-216.0	Crankcase	1	23	9.802-944.0	Hexagonal Screw	8
2*	See Kits Below	Plunger Oil seal	3	24	8.717-210.0	Closed Bearing Housing	1
3*	See Kits Below	O-Ring Ø1.78 x 31.47	3	25	9.803-192.0	O-Ring Ø1.78 x 60.05	2
4*	See Kits Below	Pressure Ring	3	26	8.933-011.0	Tapered Roller Bearing	2
5*	See Kits Below	U-Seal	3	27	9.803-146.0	Crankshaft (3540)	1
6*	See Kits Below	Intermediate Ring	3		9.803-147.0	Crankshaft (4035)	1
7*	See Kits Below	U-Seal	3	28	9.803-167.0	Crankshaft Key	1
8	9.803-199.0	Washer, Copper	1	29	9.802-921.0	Oil Dip Stick	1
9	9.802-926.0	Plug, Brass 1/2	1	30	9.803-140.0	Crankshaft Seal	1
10	8.751-218.0	Manifold Head	1	31	9.803-178.0	Shim	2
11*	See Kits Below	O-Ring Ø2.62 x 17.13	6	32	8.717-209.0	Bearing Housing	1
12*	See Kits Below	Valve Assembly	6	33*	See Kits Below	Plunger Nut, M8	3
13*	See Kits Below	O-Ring Ø2.62 x 20.29	6	34*	See Kits Below	Copper Spacer	3
14	9.802-928.0	Valve Plug	6	35*	See Kits Below	Plunger (4035) Plunger (3540)	3 3
15	9.802-938.0	Manifold Stud Bolt	8	36*	See Kits Below	Copper Spacer	3
16	9.802-884.0	Washer	16	37*	See Kits Below	O-Ring Ring	3
17	9.803-198.0	Copper Washer 3/8	1	38*	See Kits Below	Teflon Ring	3
18	9.802-925.0	Brass Plug 3/8	2	39	9.803-144.0	Plunger Rod	3

M.3 SERIES PUMP EXPLODED VIEW PARTS LIST (CONT.)

ITEM	PART NO.	DESCRIPTION	QTY
40	9.803-158.0	Connecting Rod	3
41	8.751-228.0	Connecting Rod Pin	3
42	9.803-218.0	Spring Washer	6
43	9.803-238.0	Connecting Rod Screw	6
44	70-060009	O-Ring, Ø2.62 x 126.67	1
45	8.751-229.0	Crankcase Cover	1
46	9.803-197.0	O-Ring, Ø1.78 x 14	1
47	9.803-202.0	Sight Glass 3/4	1
48	9.802-939.0	Cover Screw	5

* Available in kit (See below)

REPAIR KIT NO.	8.725-360.0	8.725-358.0	8.725-361.0	8.725-359.0	8.725-237.0	8.933-023.0	9.802-603.0	9.802-609.0
KIT DESCRIPTION	Plunger Seal 4035 18mm	Plunger Seal 3540 15mm	Complete Seal Packing 4035 18mm	Complete Seal Packing 3540 15mm	Plunger 4030 18mm	Plunger 3540 15mm	Complete Valve	Plunger Oil Seals
ITEM NUMBERS INCLUDED	3, 5, 7	3, 5, 7	3, 4, 5, 6, 7	3, 4, 5, 6, 7	33, 34, 35, 36, 37, 38	33, 34, 35, 36, 37, 38	11, 12, 13	2
NO. OF CYLINDERS KIT WILL SERVICE	3	3	1	1		1	6	3

HX.2 PUMP EXPLODED VIEW

8.715-242.0

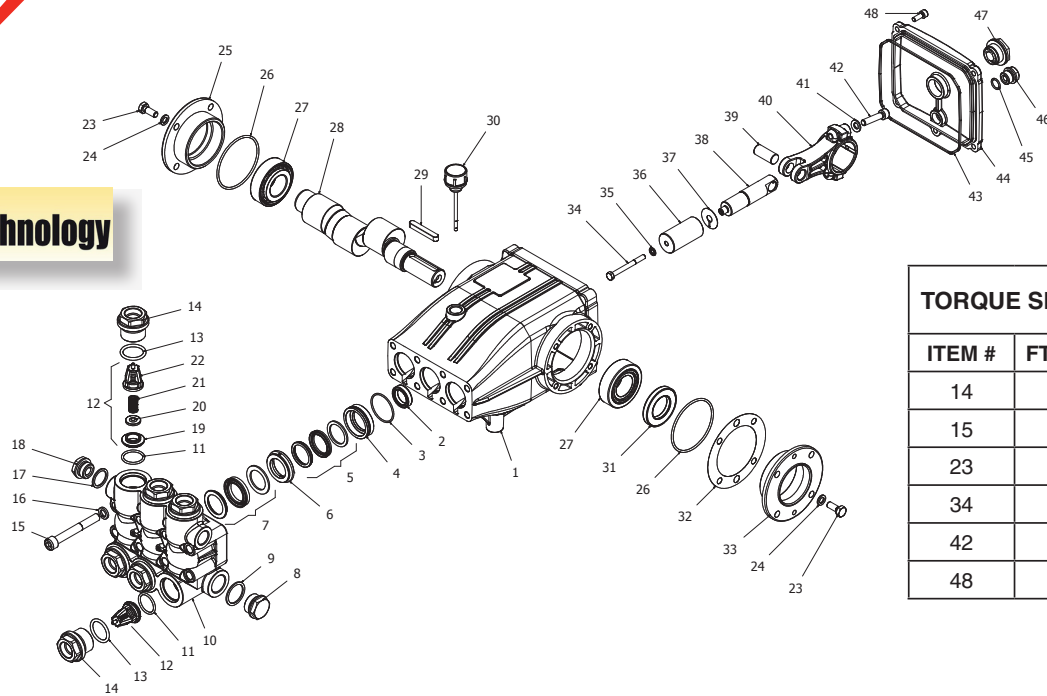

TORQUE SPECS	
ITEM #	FT. LBS.
14	95
15	45
23	8
34	10
42	30
48	8

HX.2 PUMP PARTS LIST

ITEM	PART NO.	DESCRIPTION	QTY	ITEM	PART NO.	DESCRIPTION	QTY
1	8.752-825.0	Crankcase	1	19	See Kits Below	Valve Seat	6
2*	See Kits Below	Plunger Oil seal	3	20	See Kits Below	Valve Plate	6
3*	See Kits Below	O-Ring Ø1.78 x 37.82	3	21	See Kits Below	Valve Spring	6
4*	See Kits Below	Pressure Ring	3	22	See Kits Below	Valve Cage	6
5*	See Kits Below	U-Seal, 25mm	3	23	8.752-830.0	Hex Screw	8
6*	See Kits Below	Intermediate Ring	3	24	9.802-884.0	Washer	8
7*	See Kits Below	U-Seal	3	25	9.803-182.0	Closed Bearing Housing	1
8*	9.803-285.0	Brass Plug, G3/4"	1	26	9.803-186.0	O-Ring Ø2.62 x 71.12	2
9	9.803-286.0	Washer, Copper 3/4"	1	27	9.803-160.0	Roller Bearing	2
10	8.752-831.0	Manifold Housing Ø22/Ø20	1	28	8.752-828.0	Crankshaft Ø25 (5843)	1
11	8.752-836.0	O-Ring Ø2.62 x 21.89	6	28	8.752-829.0	Crankshaft Ø25 (8043, 9536)	1
12*	See Kits Below	Valve Assembly	6	28	8.752-827.0	Crankshaft Ø25 (1036)	1
13*	9.803-287.0	O-Ring Ø3.53 x 25.80-134	6	29	9.803-293.0	Crankshaft Key	1
14	8.752-855.0	Valve Plug	6	30	8.752-834.0	Oil Dop Stick	1
15	8.752-833.0	Manifold Stud Bolt	8	31	9.803-139.0	Crankshaft Seal	1
16	9.802-890.0	Lock Washer	8	32	9.803-177.0	Shim	2
17	9.803-199.0	Copper Washer 1/2"	1	33	9.803-181.0	Bearing Housing	1
18	9.802-926.0	Brass Plug 1/2"	1	34*	8.752-841.0	Plunger Bolt	3

HX.2 PUMP PARTS LIST

ITEM	PART NO.	DESCRIPTION	QTY
35*	8.752-820.0	Bonded Seal	1
36*	8.752-846.0	Plunger, 20mm (5843, 8043)	3
	8.752-847.0	Plunger, 22mm (9539, 1036)	3
37*	8.752-823.0	Copper Spacer	3
38*	8.752-842.0	Plunger Rod	3
39*	8.752-822.0	Connecting Rod Pin	3
40	8.752-821.0	Connecting Rod	3
41*	9.802-889.0	Spring Washer	6
42*	9.802-937.0	Connecting Rod Screw	6
43	9.803-194.0	O-Ring Ø2.62 x 152.07	1
44	8.752-826.0	Crankcase Cover	1
45	9.803-906.0	O-Ring Ø1.78 x 14.00	1
46	8.707-262.0	Brass Plug G3/8"	1
47	9.803-202.0	Sight Glass G3/4"	1
48	8.752-824.0	Cover Screw	5

*Available in Kit (See Below)

REPAIR KIT NO.	8.752-843.0	8.725-844.0	8.725-849.0	8.725-850.0	8.752-838.0	8.752-839.0	8.752-853.0	8.752-835.0
KIT DESCRIPTION	Plunger Seal 20 mm (5843, 8043)	Plunger Seal 22 mm (9536, 1036)	Seal Packing 22 mm (5843, 8043)	Seal Packing 22 mm (9536, 1036)	Plunger 20 mm (5843, 8043)	Plunger 22 mm (9536, 1036)	Complete Valve	Plunger Oil Seals
ITEM NUMBERS INCLUDED	3, 5, 7	3, 5, 7	3, 4, 5, 6, 7	3, 4, 5, 6, 7	34, 35, 36, 37	34, 35, 36, 37	11, 12, 13	2
NO. OF CYLINDERS KIT WILL SERVICE	3	3	1	1	1	1	6	6

T.1 SERIES PUMP EXPLODED VIEW

9.802-345.0

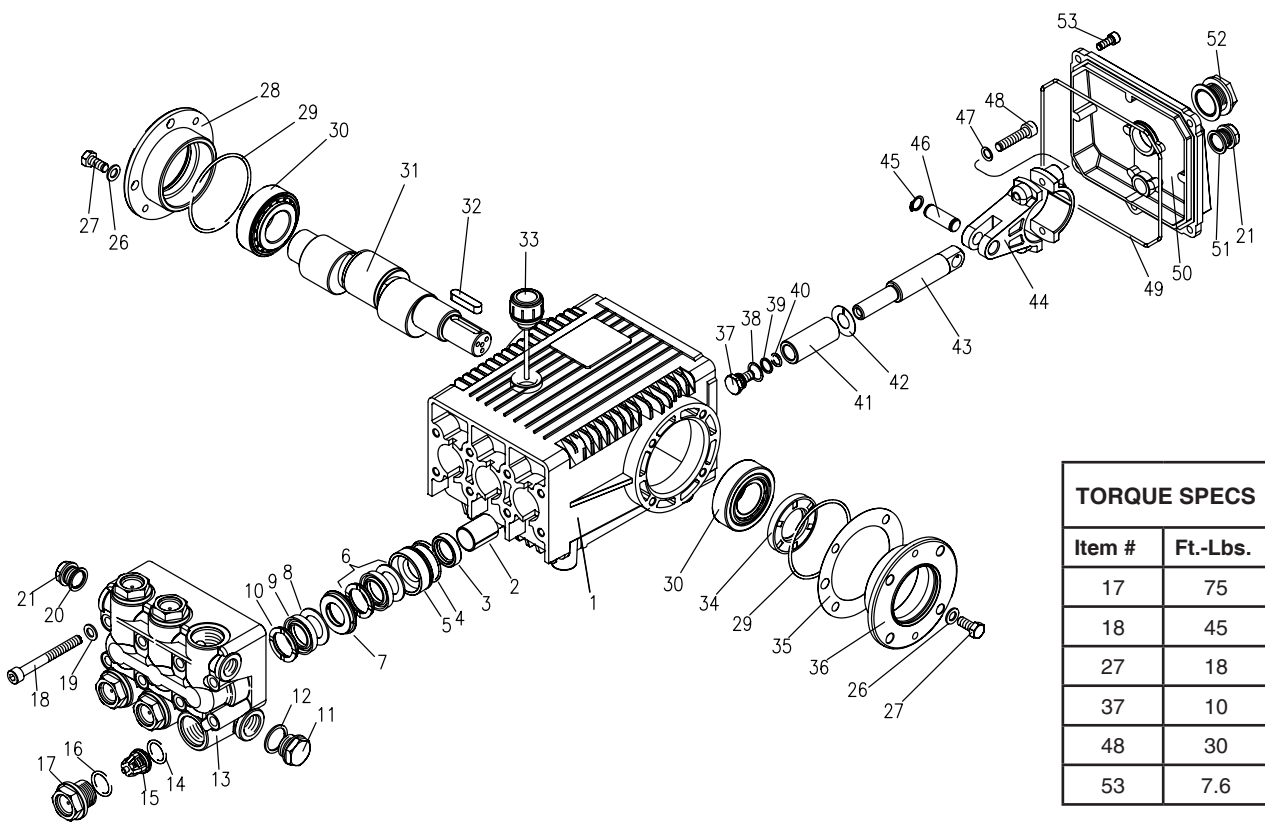

TORQUE SPECS	
Item #	Ft.-Lbs.
17	75
18	45
27	18
37	10
48	30
53	7.6

T.1 SERIES PUMP EXPLODED VIEW & PARTS LIST

ITEM	PART NO.	DESCRIPTION	QTY	ITEM	PART NO.	DESCRIPTION	QTY
1	9.804-604.0	Crankcase	1	19	9.802-890.0	Washer	8
2	9.803-195.0	Plunger Guide	3	20	9.803-198.0	Copper Washer 3/8"	1
3*	See Kit	Plunger Oil Seal	3	21	9.802-925.0	Brass Plug 3/8"	1
4*	See Kit	O-Ring Ø1.78 x 31.47	3	26	9.802-884.0	Washer	8
5*	See Kit	Pressure Ring, Brass	3	27	9.802-944.0	Hexagonal Screw	8
6*	See Kit	"U" Seal Low Pressure	3	28	9.803-182.0	Closed Bearing Housing	1
7*	See Kit	Intermediate Ring, Brass	3	29	9.803-186.0	O-Ring Ø2.62 x 71.12	2
8*	See Kit	Support Ring, Teflon Bronze	3	30	9.803-160.0	Roller Bearing, Tapered	2
9*	See Kit	"U" Seal High Pressure	3	31	9.803-149.0	Crankshaft (4035.1)	1
10*	See Kit	Support Ring	3	32	9.803-167.0	Crankshaft Key	1
11	9.802-926.0	Brass Plug, 1/2"	1	33	9.802-923.0	Oil Dip Stick	1
12	9.803-199.0	Copper Washer 1/2"	1	34	9.803-139.0	Crankshaft Seal	1
13	9.802-933.0	Manifold Head	1	35	9.803-177.0	Shim	2
14*	See Kit	O-Ring Ø2.62 x 17.13	6	36	9.803-181.0	Bearing Housing	1
15*	See Kit	Valve Assembly	6	37*	See Kit	Plunger Bolt	3
16	See Kit	O-Ring Ø2.62 x 20.29	6	38*	See Kit	Copper Spacer	38
17	9.802-928.0	Valve Plug	6				
18	9.802-943.0	Manifold Stud Bolt	1				

LT.2 PUMP EXPLODED VIEW AND PARTS LIST

8.921-710.0 LT4540.2 Right
 8.921-711.0 LT4540.2 Left
 8.921-712.0 LT6036.2 Right
 8.921-713.0 LT6036.2Left

G₃ Evolution

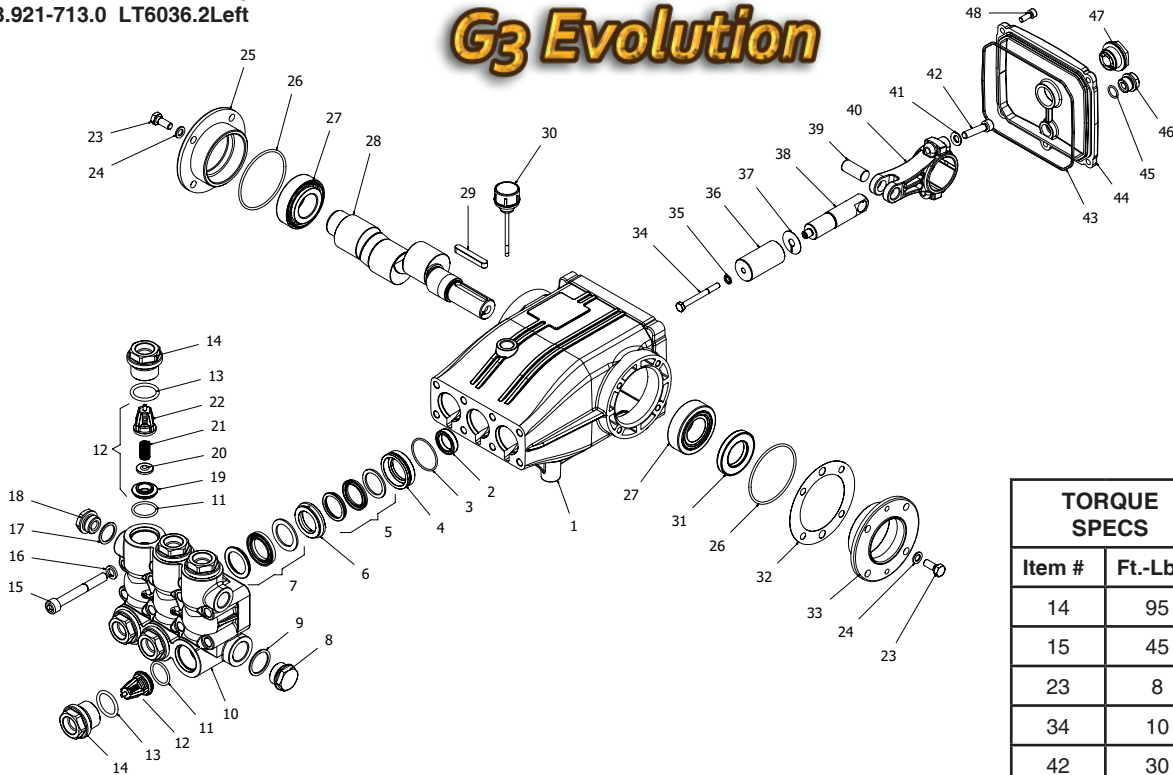

TORQUE SPECS	
Item #	Ft.-Lbs.
14	95
15	45
23	8
34	10
42	30
48	8

LT PUMP EXPLODED VIEW PARTS LIST

ITEM	PART NO.	DESCRIPTION	QTY	ITEM	PART NO.	DESCRIPTION	QTY
1	8.752-825.0	Crankcase	1	19	See Kit Below	Valve Seat	6
2*	See Kit Below	Plunger Oil Seal	3	20	See Kit Below	Valve Plate	6
3*	See Kit Below	O-Ring Ø1.78 x 37.82	3	21	See Kit Below	Valve Spring	6
4*	See Kit Below	"Pressure Ring, Brass	3	22	See Kit Below	Valve Cage	6
5*	See Kit Below	"U" Seal 18mm	3	23	8.725-830.0	Hexagonal Screw	8
6*	See Kit Below	Intermediate Ring, 18mm	3	24	9.802-884.0	Washer	8
7*	See Kit Below	"U" Seal, 18mm	3	25	9.803-182.0	Closed Bearing Housing	1
8	9.802-926.0	Brass Plug, G1/2	1	26	9.803-186.0	O-Ring Ø2.62 x 71.12	2
9	9.803-199.0	Cooper Washer 1/2	1	27	9.803-160.0	Roller Bearing	2
10	8.753-816.0	Manifould Housing	1	28	8.753-818.0	Crankshaft Ø24 (4540)	1
11*	9.804-498.0	O-Ring Ø2.62 x 25.1	6		8.752-827.0	Crankshaft Ø24 (6036)	1
12*	See Kit Below	Valve Assembly	6	29	9.803-167.0	Cranckshaft Key	1
13*	9.803-193.0	O-Ring 3068	6	30	8.752-834.0	Oil Dipstick	1
14	9.802-928.0	Valve Plug	6	31	9.803-139.0	Crankshaft Seal	1
15	8.753-817.0	Manifould Stud Bolt	8	32	9.803-177.0	Shim	2
16	9.802-890.0	Lock Washer	8	33	9.803-181.0	Bearing Housing	3
17	8.719-008.0	Cooper Washer 3/8	1	34*	8.752-841.0	Plunger Bolt	3
18	8.707-262.0	Brass Plug 3/8	1				

LT PUMP EXPLODED VIEW PARTS LIST (CONT)

ITEM	PART NO.	DESCRIPTION	QTY
35*	8.752-820.0	Bonded Seal	3
36*	8.753-819.0	Plunger 18mm	3
37*	8.752-823.0	Copper Spacer	3
38	See Kit Below	Plunger Rod	3
39	8.752-822.0	Connecting Rod Pin	3
40	8.752-821.0	Connecting Rod	3
41	9.802-889.0	Spring Washer	6
42	9.802-937.0	Connecting Rod Screw	6
43	9.803-194.0	O-Ring Ø2.62 x 152.07	1
44	8.752-826.0	Crankcase Cover	1
45	9.803-906.0	O-Ring Ø1.78 x 14.00	1
46	8.707-262.0	Brass Plug G 3/8	1
47	9.803-202.0	Sight Glass G3/4	1
48	8.752-824.0	Cover Screw	5

* Part available in kit (See below)

REPAIR KIT NUMBER	8.753-821.0	8.753-822.0	8.753-823.0	8.753-824.0	8.752-835.0
KIT DESCRIPTION	Plunger Seal 18mm	Seal Packing 18mm	Plunger 18mm	Complete Valve	Plunger Oil Seals
ITEM NUMBERS INCLUDED	3,5,7	3,4,5,6,7	34,35,36,37	11,12,13	2
NUMBER OF CYLINDERS KIT WILL SERVICE	3	1	1	6	3

T.1 SERIES PUMP EXPLODED VIEW & PARTS LIST

ITEM	PART NO.	DESCRIPTION	QTY
39*	See Kit	O-Ring Ø1.78 x10.82	3
40*	See Kit	Teflon Ring	3
41*	See Kit	Plunger	3
42*	See Kit	Copper Spacer	3
43	9.803-143.0	Plunger Rod	3
44	9.803-157.0	Connecting Rod	3
45	9.802-912.0	Snap Ring	6
46	9.802-915.0	Connecting Rod Pin	3
47	9.802-889.0	Spring Washer	6
48	9.802-937.0	Connecting Rod Screw	6
49	9.803-194.0	O-Ring Ø2.62 x 152.07	1
50	9.803-166.0	Crankcase Cover	1
51	9.803-197.0	Gasket, G3/8	1
52	9.803-202.0	Sight Glass G3/4	1
53	9.802-939.0	Cover Screw	5

* Part available in kit (See below)

REPAIR KIT NUMBER	8.916-488.0	8.916-322.0	9.802-607.0	9.802-603.0	9.802-606.0
KIT DESCRIPTION	Plunger "U" Seal 20mm 4035.1	"U" Seal Packing Assy 20mm 4035.1	Plunger 20mm 4035.1	Complete Valve	Plunger Oil Seals
ITEM NO.S INCLUDED	4, 6, 8, 9, 10	4, 5, 6, 7, 8, 9, 10,	37, 38, 39, 40, 41, 42	14, 15, 16	3
NUMBER OF CYLINDERS KIT WILL SERVICE	3	1	1	6	3

VRT3 UNLOADER EXPLODED VIEW AND PARTS LIST

8.750-300.0, 8 GPM, 4500 PSI EZ Start

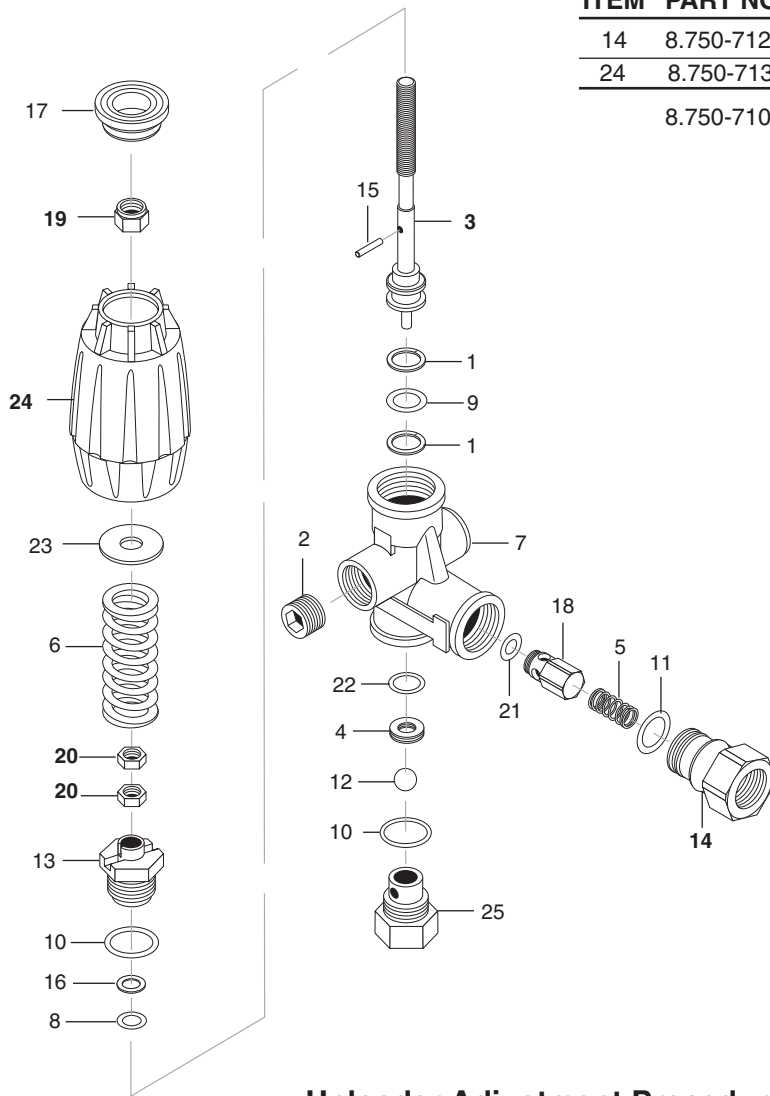

ITEM	PART NO.	DESCRIPTION	QTY
14	8.750-712.0	Outlet Fitting	1
24	8.750-713.0	Knob, Unloader	1
		8.750-710.0	Repair Kit, VRT3, 4500 PSI
		(Kit Items: 1, 4, 8-12, 16, 21-22)	

Unloader Adjustment Procedures

1. Remove lock nut (Item 19).
2. Remove adjustment knob (Item 24).
3. Loosen the two (2) nuts (Item 20), move them upward on stem (Item 3) until you see 4 or more threads below the nut.
4. Re-attach adjusting knob (Item 24).
5. Start machine. Open the trigger of the spray gun. Increase pressure by turning adjustment knob (Item 24) clockwise until pressure is at the desired operating pressure.
6. Remove the adjustment knob (Item 24), tighten the lower nut (Item 20) tightly against the upper nut (Item 20). Re-attach adjustment knob (Item 24) and screw down until contact is made with the nuts (Items 20). Screw down lock nut (Item 19) onto the stem (Item 3) until the threads cut into the nylon insert of the lock nut (Item 19).

*If adjustment knob (Item 24) **DOES NOT** make contact with upper nut (Items 20), remove adjusting knob (Item 24), re-adjust (raise) nuts (Items 20) on stem (Item 3) and re-attach adjustment knob (Item 24), then repeat step #6.

If adjustment knob (Item 24) **DOES make contact with upper nut; release the trigger of the spray gun and watch the pressure gauge for the pressure increase ("spike"). This "spike" **SHOULD NOT** exceed 500 psi above the operating pressure. If "spike" pressure exceeds the 500 psi limit, remove the adjusting knob (Item 24) and re-adjust (lower) the nuts (Items 20) on the stem (Item 3). Re-attach the adjusting knob (Item 24), then repeat step #6.

VB350/4 UNLOADER EXPLODED VIEW

9.802-360.0, 10.5 GPM at 5100 PSI

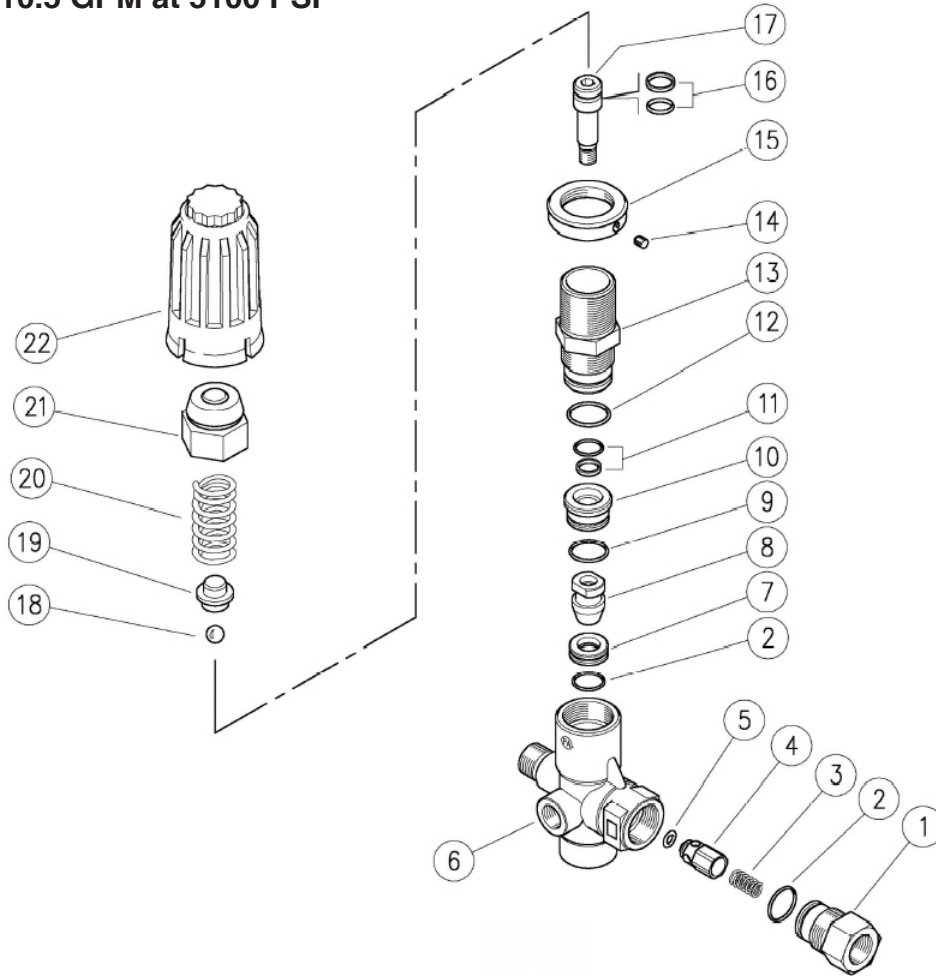

VB UNLOADER EXPLODED VIEW PARTS LIST

ITEM	PART #	DESCRIPTION	QTY	ITEM	PART #	DESCRIPTION	QTY
1	60.1811.31	3/8 Bsp F Nipple	1	16	60.0978.24*	VB280-350 Val. Pist. Seal Repair Set	1
2	10.3066.01*	O-Ring, 1.78 x 15.6 mm	2	17	60.1806.51	M8 Piston	1
3	60.0053.51	Spring	1	18	14.7443.10*	Sst 11/32" Ball	1
4	60.0052.51	Sst Check Valve	1	19	60.1813.31	Spring Guide	1
5	10.3213.08*	O-Ring, 3 x 6mm	1	20	60.0975.61	4.2 mm Spring (60.1600.00)	1
6	60.1725.35	VB280-350 Brass Body	1		60-1812.61	4.5 x 47 mm Spring (60.1700.00)	1
7	60.1809.51*	Seat	1	21	60.1727.31	Brass Cap	1
8	60.1808.51*	M 8 Shutter	1	22	60.1726.84	VB280 Black Plastic Knob (60.1600.00)	1
9	10.3068.01*	O-Ring, 1.78 x 17.17 mm	1		60.1729.84	VB350.4 Red Plastic Knob (60.1700.00)	1
10	60.1810.31	Spacer	1				
11	60.0979.24*	VB280-350 Val. Pist. Seal Repair Set	1				
12	10.3072.01*	O-Ring, 1.78 x 20.35 mm	1				
13	60.0973.31	Piston Housing (60.1600.00)	1				
	60.1805.31	Piston Housing (60.1700.00)	1				
14	16.2100.00	M 4 x 4 mm Dowel	1				
15	60.1728.31	Lock Nut	1				

*Kit :

K1 60.1615.24 VB280-350.4 Spare Parts Kit Pcs. 11 x 1

TROUBLESHOOTING

PROBLEM	POSSIBLE CAUSE	SOLUTION
LOW OPERATING PRESSURE	Insufficient water supply. Closed faucet. Inlet hose kinked	Use larger garden hose; clean inlet water screen. Open faucet.
	Clogged inlet hose strainer	Check plumbing system for leaks. Retape leaks with teflon tape.
	Faulty or mis-adjusted unloader valve	Adjust unloader for proper pressure. Install repair kit when needed. Contact local dealer or technical support.
	Worn packing in pump	Contact local dealer.
	Machine has been stored in freezing temperatures	Thaw out machine completely, including hose, spray gun and wand.
	Slow engine RPM	Contact local dealer or technical support.
FLUCTUATING PRESSURE	Worn or dirty pump valves	Contact local dealer or technical support.
	Nozzle is obstructed	Use nozzle wire in accessory kit.
	Pump sucking air, inlet hose leaking	Check all pump lines and connections.
PRESSURE LOW AFTER PERIOD OF NORMAL USE	Nozzle worn	Replace nozzle.
	Unloader valve worn	Replace unloader valve.
ENGINE WILL NOT START OR STOPS WHILE OPERATING	Low oil shutdown	Fill engine with oil.
	Out of gas	Fill fuel tank.
	Water in gasoline	Drain gas tank; fill with clean fuel.
ENGINE IS OVERLOADED	Nozzle partially blocked	Clean nozzle.
	Excessive pressure from high engine RPM	Adjust engine throttle to lower RPM.
WATER OR OIL LEAKING FROM BOTTOM OF PUMP	A small amount of leaking is normal	If excessive leaking occurs, contact your local dealer.
PRESENCE OF WATER IN PUMP OIL	Water sprayed at machine	Change oil. Direct spray away from machine.
	High humidity in air	Check and change oil twice as often.
	Piston packing worn. Oil seal worn.	Contact local dealer or technical support.

TROUBLESHOOTING

PROBLEM	POSSIBLE CAUSE	SOLUTION
ENGINE OPERATES FOR 15 MIN. THEN STOPS	Not enough gas or engine oil	Fill tank with gas. Check oil level.
	Vapor lock developed by heat of day	Keep gas tank full to avoid vapor locking.
	Obstruction in fuel filter	Clean or replace fuel filter.
ENGINE LACKS POWER	Dirty air filter	Replace air filter.
ENGINE FALTERS	Choke is opened too soon	Move choke to halfway position until engine runs smoothly.
WATER DRIPPING FROM UNDER PUMP	Piston packing worn	Contact local dealer or technical support.
	O-Ring plunger retainer worn	Contact local dealer or technical support.
	Cracked piston	Contact local dealer or technical support.
OIL DRIPPING	Oil seal worn or damaged	Contact local dealer or technical support.
WATER LEAKING FROM PUMP PROTECTOR	Spray gun closed with machine running 5 minutes or longer	Open spray gun or turn off machine.
	Excess water supply pressure	Place a pressure regulator at end of 50' garden hose.
NO DETERGENT	Detergent suction tube not properly connected to machine	Check connection.
	Detergent is too thick	Dilute detergent. For best results, use our detergent.
	Detergent filter valve is at lowest setting	Set detergent filter valve to a higher setting.
	Filter on detergent suction tube is clogged	Run warm water through filter to remove debris.
	Damaged or clogged detergent suction tube	Remove obstruction or replace detergent suction tube.
	A high pressure nozzle is attached.	Replace with black detergent nozzle.
	Discharge nozzle is obstructed	Blow out or remove debris with fine needle.
GARDEN HOSE CONNECTION LEAKS	Loose fittings	Tighten fittings.
	Missing/worn rubber washer	Insert new washer.
SPRAY WAND LEAKS	Spray wand not properly attached	Slide the spray wand into the gun. Turn the wand collar clockwise onto the spray gun threads until tight.
	Broken o-ring	Contact local dealer to order an o-ring.
PUMP IS NOISY	Pump is sucking air	Check that hoses and fittings are air tight. Turn off machine and purge pump by squeezing trigger gun until a steady flow of water emerges through nozzle.

