

## CONTROL HEAD (9.001-361.0) REPLACEMENT

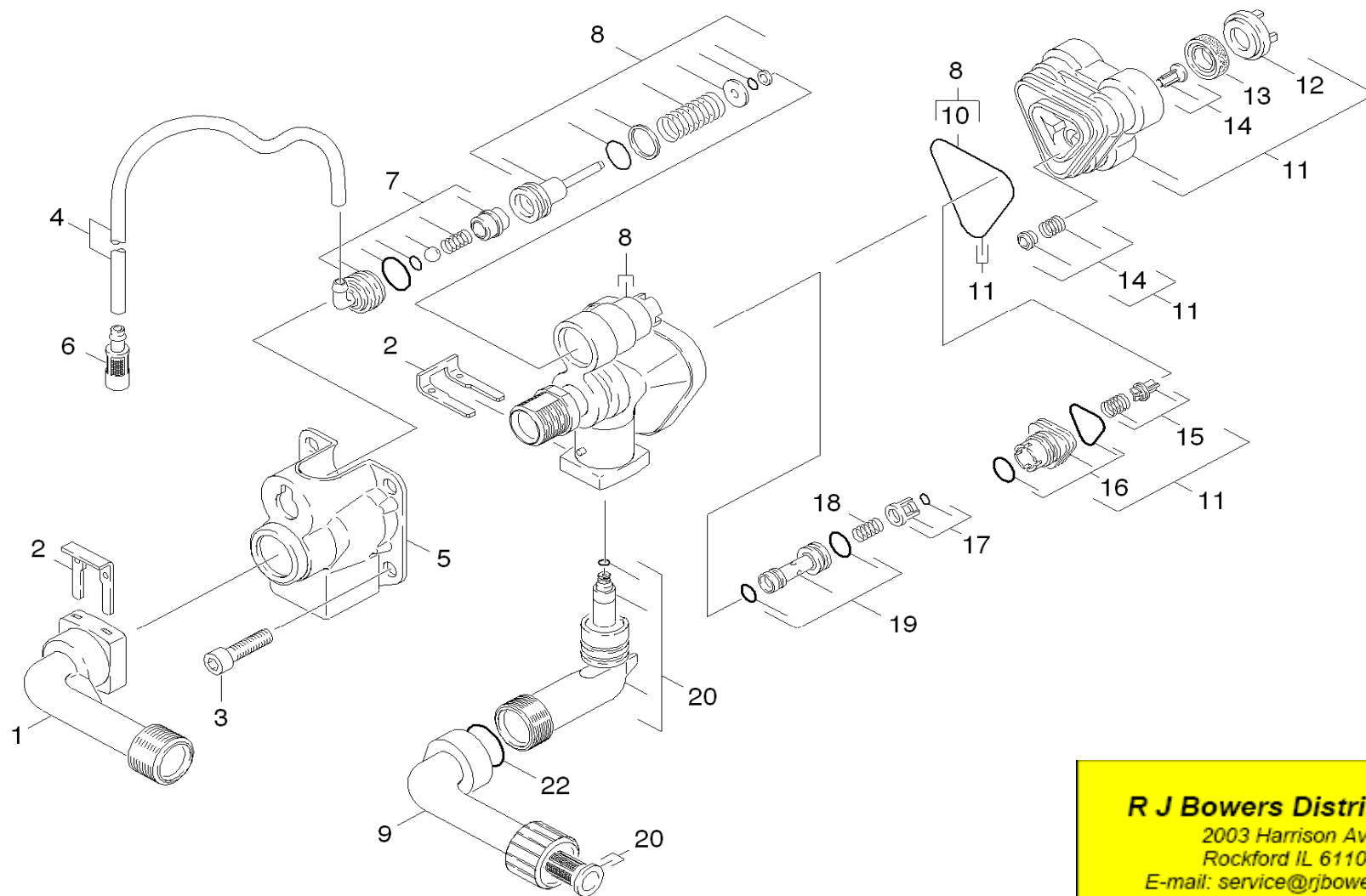

### **R J Bowers Distributors**

2003 Harrison Ave

Rockford IL 61104

E-mail: [service@rjbowers.com](mailto:service@rjbowers.com)

Web: [www.rjbowers.com](http://www.rjbowers.com)

(815) 399-8839 (800) 383-6584

Parts that need to be **removed** from the old pump (# 8) and **reinstalled** in new one (9.001-361.0)

# 7: Detergent Inlet Assembly (use pliers and pull straight out)

#3: Need 6mm Allen Wrench to remove.

#19: Nozzle Insert w/2 o-rings

#18: Spring

#17: Cage w/o-ring on top

**NO #:** Check Valve inserted in bottom of #8 (part of Water Inlet Elbow #20)

O-Ring (not shown) for HP Outlet Elbow (#1). Confirm when removing o-ring, may be inside #1 or 8