



Water Inlet Elbow Replacement Instructions

PART NUMBER 9.001-187.0 & 9.001-188.0

Step One:

Remove the outer cover by removing the 6 to 8 screws that hold the cover together, Separate the covers. The tool needed to remove the screws: "Torx" screwdriver, size T-15, approx. 6 inch long shaft.
"You can purchase the Torx driver from R.J. Bowers Distributors: Part No. CR-47181 Price \$13.73"

Step Two:

Remove the four Hex headed screws #14 that hold the pump together. You will need a 6mm Allen wrench.

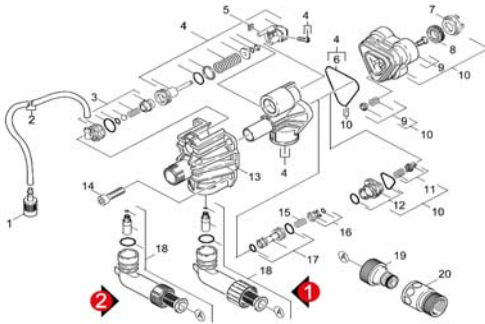

See larger parts breakdown on back



Step Three:

Separate the plastic pump (4) from the metal housing (13) by inserting a flat bladed screwdriver into the slot on the side of the pump. The two parts will separate when you work the screwdriver between the metal and plastic by twisting. Do not pry.

If this method does not work, place assembly in freezer over night. Plastic pump will separate from the metal housing in an easy manor. Make sure that when placing assembly in the freezer there is no water inside.

Step Four:



Remove broken inlet tube from Control Head. Remove old and replace new Check Valve. Lubricate o-ring and insert new Check Valve into Control Head.



R J Bowers Distributors Inc.

2003 Harrison Av.
Rockford, IL 61104

Web: rjbowers.com

(800) 383-6584

Fax: (815) 399-8839

Email: parts@rjbowers.com



Water Inlet Elbow Replacement Instructions

Step Five:



Insert Water Inlet Elbow (9001-1880 or 9001-1870) into bottom of Control Head. Line up tab with guide on back side of Control Head. If Inlet Elbow does not slide evenly into Control Head, pull Check Valve to center of opening and insert Elbow at angle as shown in picture on left



Step Six:



Complete Inlet Elbow & Control Head assembly. Bolt the pump back together "be sure that all parts are in the correct place." Replace the housing.

Pump Breakdown

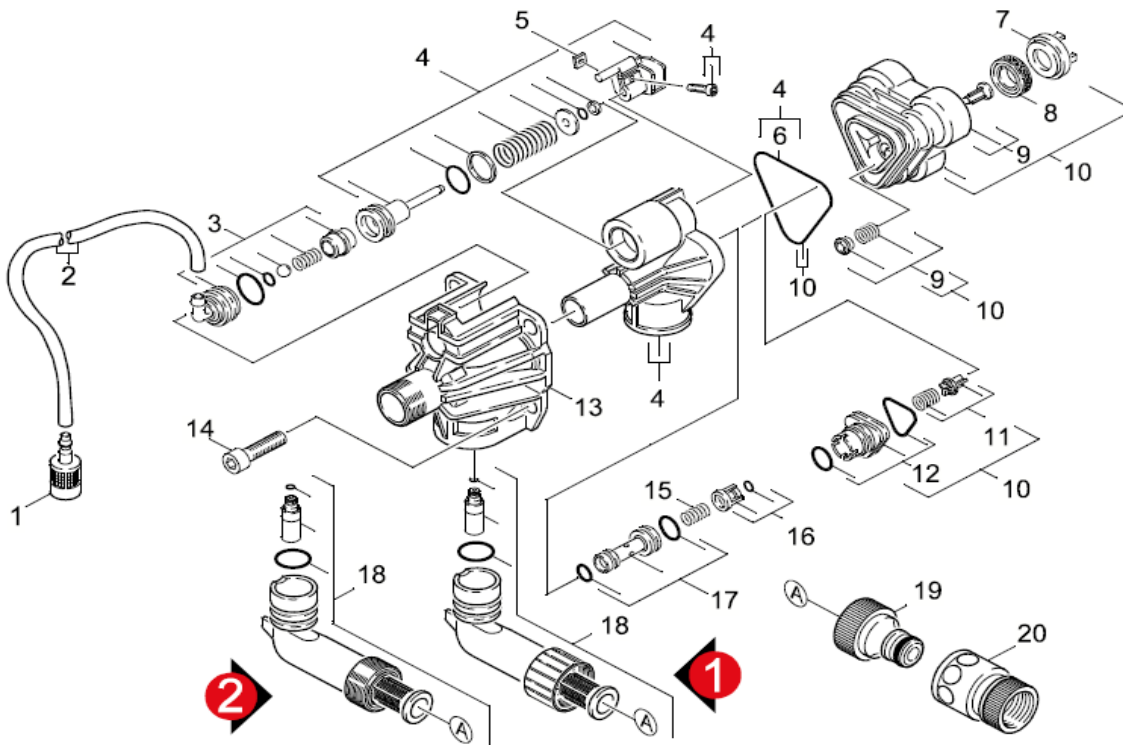

R J Bowers Distributors Inc.

2003 Harrison Av.
Rockford, IL 61104

Web: rjbowers.com

(800) 383-6584

Fax: (815) 399-8839

Email: parts@rjbowers.com