

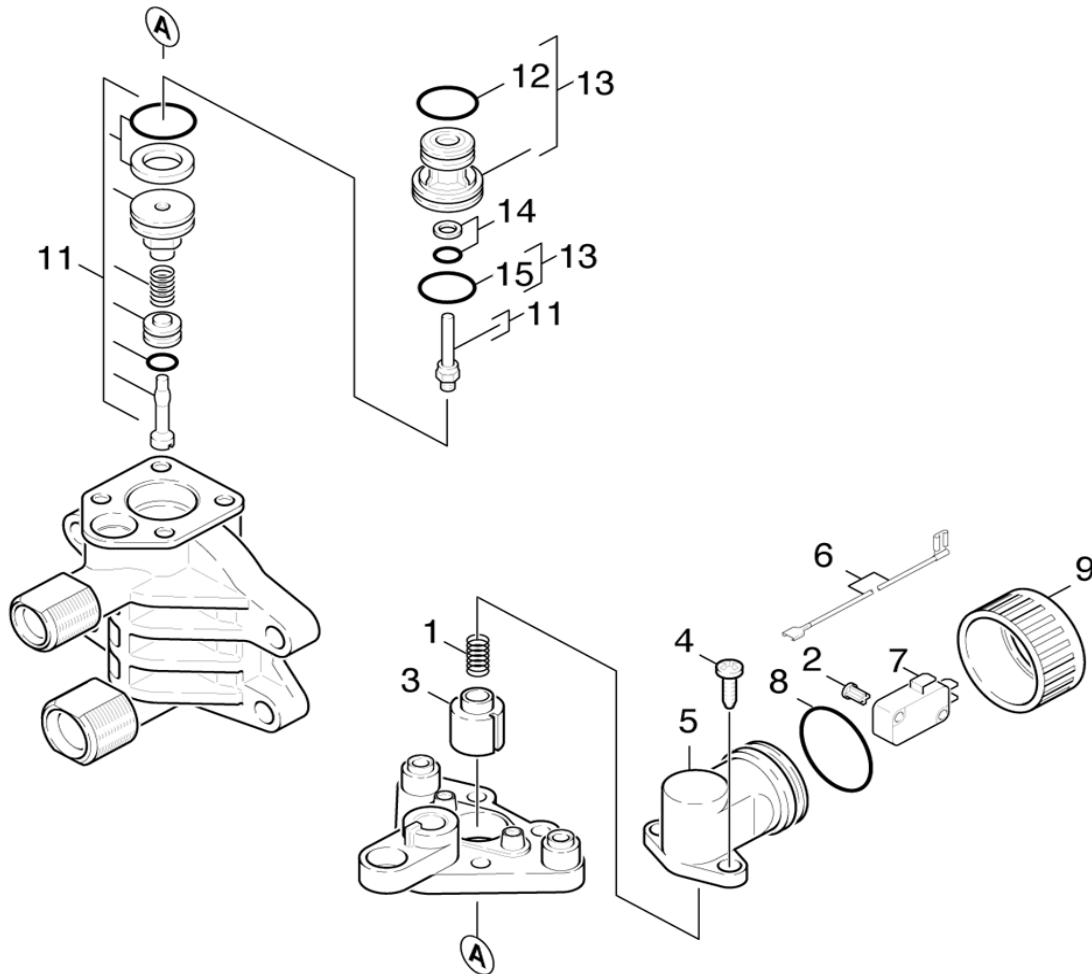

4580-2600 SPILL VALVE INSTRUCTIONS



Part 11 make up Part # 4580-2600 Spill (Unloader) Valve

Remove Spill Valve by grasping the knob at the top of the valve (# 11) with a needle-nose vice grip and pulling straight up. The Spill Valve is seated in the housing with a set of o-rings (shown but not numbered) so there will be a slight resistance.

When the valve is removed use a damp cloth to clean the valve and verify that there are no cuts, tears or damage to the o-rings. If possible clean and inspect the bore in the housing for pits or build up.

Next lubricate the top o-ring of the Spill Valve generously with silicone grease; **DO NOT LUBRICATE THE LOWER O-RING**. The lower o-ring holds the valve in place. The lubrication on the top o-ring allows the valve to open and close properly. Reinstall the valve and make sure that it is seated all the way to the bottom.

R.J. BOWERS DISTRIBUTORS INC.

2003 Harrison Av
Rockford, IL 61104

WEB: www.rjbowers.com

800-383-6584

FAX: 815-399-8839

e-mail: parts@rjbowers.com



4580-2600 SPILL VALVE INSTRUCTIONS

K 620 M (1.973-680.0) PUMP BREAKDOWN

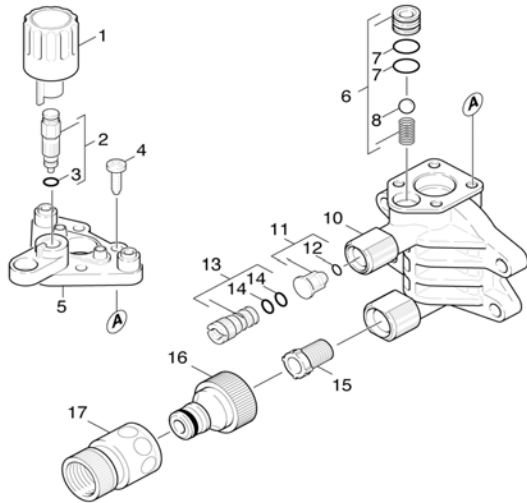

CHEMISTRY

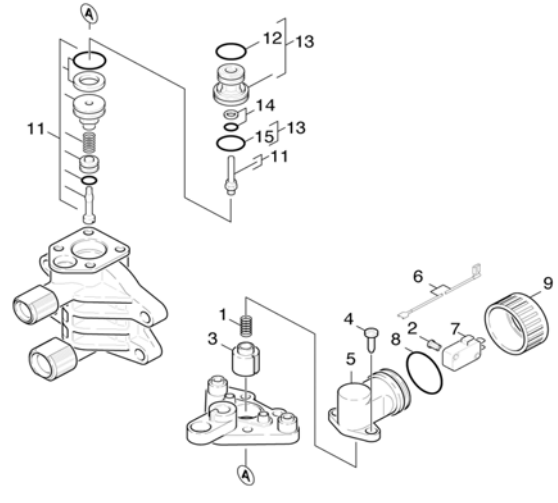

SPILL VALVE

PISTON

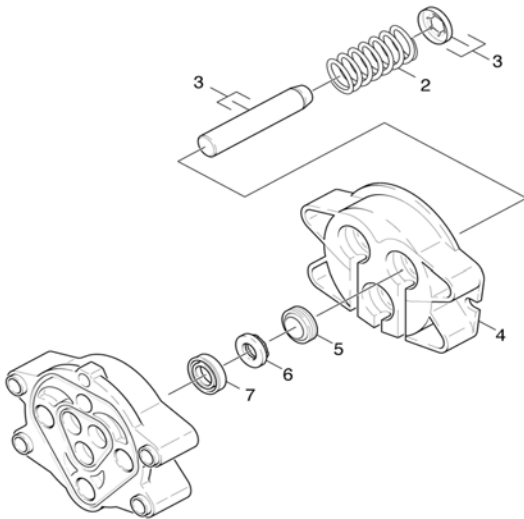

CYLINDER HEAD

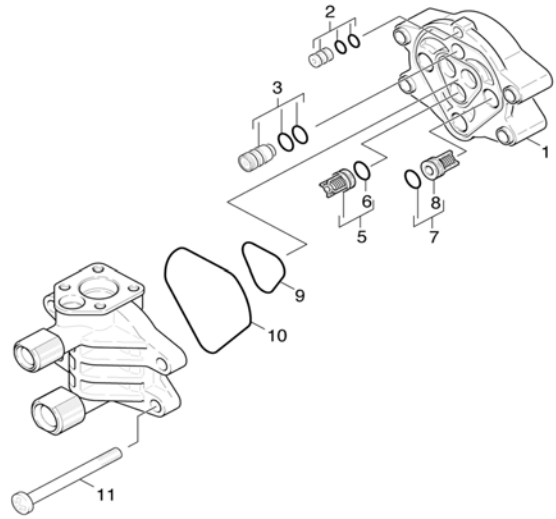

R.J. BOWERS DISTRIBUTORS INC.

2003 Harrison Av
Rockford, IL 61104

WEB: www.rjbowers.com

800-383-6584

FAX: 815-399-8839

e-mail: parts@rjbowers.com